

396-3583Y1

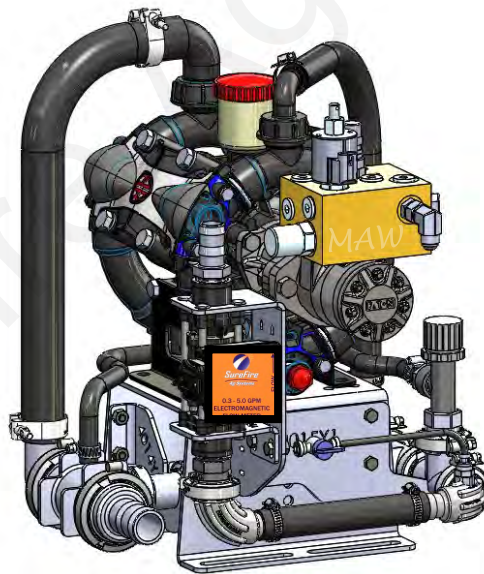

PumpRight Fertilizer System for John Deere Rate Controller 2000



NOTICE

Operator should read this manual before operating the system.

Maximum Pump Flow and Application Rates

	Number of Diaphragms	Max Flow GPM	Max GPA on 40' at 6 MPH	Max GPA on 60' at 6 MPH
PR17	3	17	35	23.5
PR30	3	30	62	41
PR40	4	40	82	55
D250	6	55		75

Table Of Contents

Introduction

- IMPORTANT SAFETY INFORMATION—*Read this first*—..... ii-iii
- Basic Steps to Install your Fertilizer System..... 1
- Complete Fertilizer System Example Drawing 2-3

A

Introduction

Components - Liquid

- Flowmeters, Section Valves, Pressure Sensor..... 4-7
- Pump Priming and Air Bleed Valve 8
- Recirculation & Agitation 9
- Flow Indicators and Manifolds, Check Valves, Orifice Charts..... 10-16
- Dual Check Valve Systems, Row Distribution 17-20

B

Components
Liquid

Components - Wiring & Electrical

- Connecting to JDRC 2000 21
- Sample Harness Layouts 22-25
- Harness Drawings, Pinouts 26-27

D

Components
Wiring & Elec.

Installation Overview

- Floating Ball Flow Indicators, PumpRight Installation 28-29
- Hydraulic Connections, PWM Valve, Hydraulic Oil Flow Requirements 30-32
- Liquid Plumbing Connections..... 33-34

E

Installation
Overview

Setup & Operation

- JDRC 2000 Setup, Profile, Application Type, Section Setup 35-36
- Pressure Sensor, RPM Sensor, Control Valve Setup 37
- Rate Sensor, Flow Cal, Fill Flowmeter 38
- Rates, Rate Smoothing, Pressure Sensor Setup/Calibration..... 38
- Run Page, Display Settings, Section Switch Box 39
- System Enable/Disable(ON/OFF), Manual/Auto Mode..... 39
- Advanced Tuning, Diagnostics/Troubleshooting Tips 39
- **Initial Operation, Manual Operation, Auto Mode Test 40**

F

Setup &
Operation

Troubleshooting

- Pump Will Not Turn, Hydraulic Manual Override 41
- Application Rate Fluctuates or Slow Getting to Target Rate..... 42
- Flowmeter Troubleshooting and Tap Test..... 43
- Flowmeter Tap Test, Section Valves Won't Move, Pressure Sensor..... 44
- More Troubleshooting Suggestions and Help..... 45-46

G

Trouble-
Shooting

Maintenance & Parts

- Air Bladder, Winterization, Pump Oil Change 47
- Replacing Valves and Diaphragms 48-49
- Pump Assembly and Part Breakdowns--see 396-4034Y1 Manual 50
- PWM Valve and Motor Parts..... 51
- Pre-season Service..... 52

H

Maintenance
& Parts

QuickStart Setup Sheet See the sheet for your harness, profile, and product setup
©2010-2021 SureFire Ag Systems—All Rights Reserved



Safety

A

TAKE NOTE! THIS SAFETY ALERT SYMBOL FOUND THROUGHOUT THIS MANUAL IS USED TO CALL YOUR ATTENTION TO INSTRUCTIONS INVOLVING YOUR PERSONAL SAFETY AND THE SAFETY OF OTHERS. FAILURE TO FOLLOW THESE INSTRUCTIONS CAN RESULT IN INJURY OR DEATH.



**THIS SYMBOL MEANS
ATTENTION!**

BECOME ALERT!

YOUR SAFETY IS INVOLVED!

Note the use of the signal words DANGER, WARNING and CAUTION with the safety messages. The appropriate signal word for each has been selected using the following guidelines:



DANGER: Indicates an imminently hazardous situation that, if not avoided, will result in death or serious injury. This signal word is to be limited to the most extreme situations typically for machine components which, for functional purposes, cannot be guarded.



WARNING: Indicates a potentially hazardous situation that, if not avoided, could result in death or serious injury, and includes hazards that are exposed when guards are removed. It may also be used to alert against unsafe practices.



CAUTION: Indicates a potentially hazardous situation that, if not avoided, may result in minor or moderate injury. It may also be used to alert against unsafe practices.

NOTICE is used to address safety practices not related to personal safety.





Hydraulic Fluid and Equipment Safety

This system uses hydraulic equipment with hydraulic fluid under extremely high pressure.

Hydraulic fluid escaping under pressure can have sufficient force to penetrate the skin causing serious injury. Keep all hoses and connections in good serviceable condition. Failure to heed may result in serious personal injury or death. Avoid the hazard by relieving the pressure before disconnecting lines or performing work on the system.

Make sure hydraulic fluid connections are tight and all hydraulic hoses and lines are in good condition before applying pressure to the system. Use a piece of paper or cardboard, **NOT BODY PARTS**, to check for suspected leaks. Wear protective gloves and safety glasses or goggles when working with hydraulic systems. **DO NOT DELAY!**

Check hydraulic hoses and fittings frequently. Loose, broken, and missing hardware can cause equipment to not perform properly and can result in serious injury or death. Hydraulic systems can be hot and cause burns. Before working on any system, wait until the fluid has cooled.

If an accident occurs, see a doctor familiar with this type of injury immediately. Any fluid injected into the skin or eyes must be treated within a few hours or gangrene may result.



A Word to the Operator

SAFETY IS YOUR RESPONSIBILITY.

YOU are the key to safety.

It is **YOUR** responsibility to read and understand the safety messages in this manual.

This system may be used to apply many different kinds of agricultural liquid products. Read and follow all label information and instructions related to the handling, storage, and application of the product you are using.

All electrical harnessing should be checked regularly and should be routed and secured so it will not be pinched, cut, or stretched.

SureFire Ag Systems



General Description

A

Introduction

You have purchased a SureFire fertilizer system for your equipment. This system will be controlled by your John Deere display and John Deere Rate Controller 2000. The Rate Controller will adjust the speed of the SureFire PumpRight hydraulic pump based on feedback from the flowmeter and vehicle speed. The system is capable of using John Deere Swath Pro and Section Control to minimize overlap areas with optional section valves.

The John Deere Rate Controller 2000 is capable of controlling up to 5 products depending on the exact situation. So, the same JDRC 2000 that controls this PumpRight system could control additional liquid, dry or anhydrous ammonia products on your equipment.

You will need a SureFire JDRC 2000 adapter harness to connect the JDRC 2000 to the product harness(es). JDRC 2000 setup instructions will be furnished with the adapter harness so all the products controlled with a single JDRC 2000 controller will work properly.

Basic Installation Steps

1. Have JDRC 2000 mounted and wiring harnesses connected by your John Deere Dealer.
2. Open the packages and familiarize yourself with the components. See the System Overview Example on the following page to see the big picture of how SureFire Fertilizer Systems are installed. Refer to manual sections B & D for component information.
3. Mount the PumpRight pump and make hydraulic connections. See section E for hydraulic plumbing information.
4. Plumb the tank to the PumpRight inlet. See section E for details.
5. Install the plumbing kit including section valves, flow indicator columns / manifolds, check valves, plumbing to each row unit delivery point. See section B for information on these components.
6. Attach the flowmeter outlet to section valve, manifold inlet, or LiquiShift inlet. Attach section valve outlets to flow indicator inlets.
7. Attach harnesses as shown in Section D.
8. Set up Controller for SureFire fertilizer system as shown in Section F or in the setup instructions sent with the JDRC 2000 adapter harness.
9. Fill system with water, conduct initial operation and tests per Section F.
10. Winterize system with RV Antifreeze if freezing temperatures are expected.
11. Do pre-season service each year as described at end of manual.

System Overview Example

The following gives an example of a complete SureFire Fertilizer system with these components:

- John Deere Display
- JDRC 2000
- PumpRight PR17
- Section Valves
- Flow Indicators
- Check Valves with Colored Disc Orifices

SureFire 47-Pin adapter harness for 1 or more products and section valves (not necessary if SureFire ECU adapter is used)

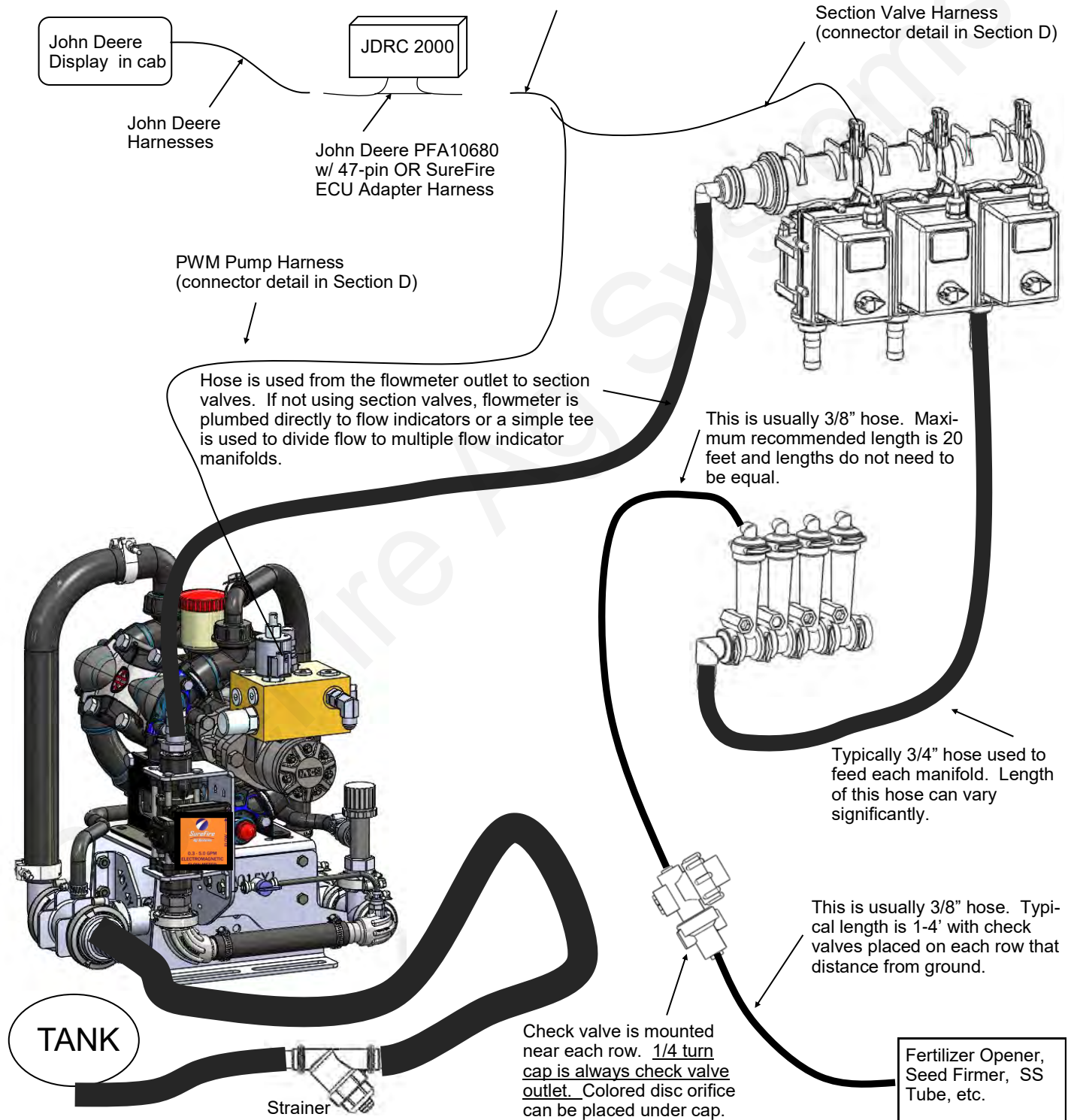

System Overview Example

A Introduction

The following gives an example of a complete SureFire Fertilizer system with LiquiShift and these components:

- John Deere Display
- JDRC 2000
- PumpRight PR17
- LiquiShift Valve Stack
- Isolated Feed Flow Indicators
- Check Valves

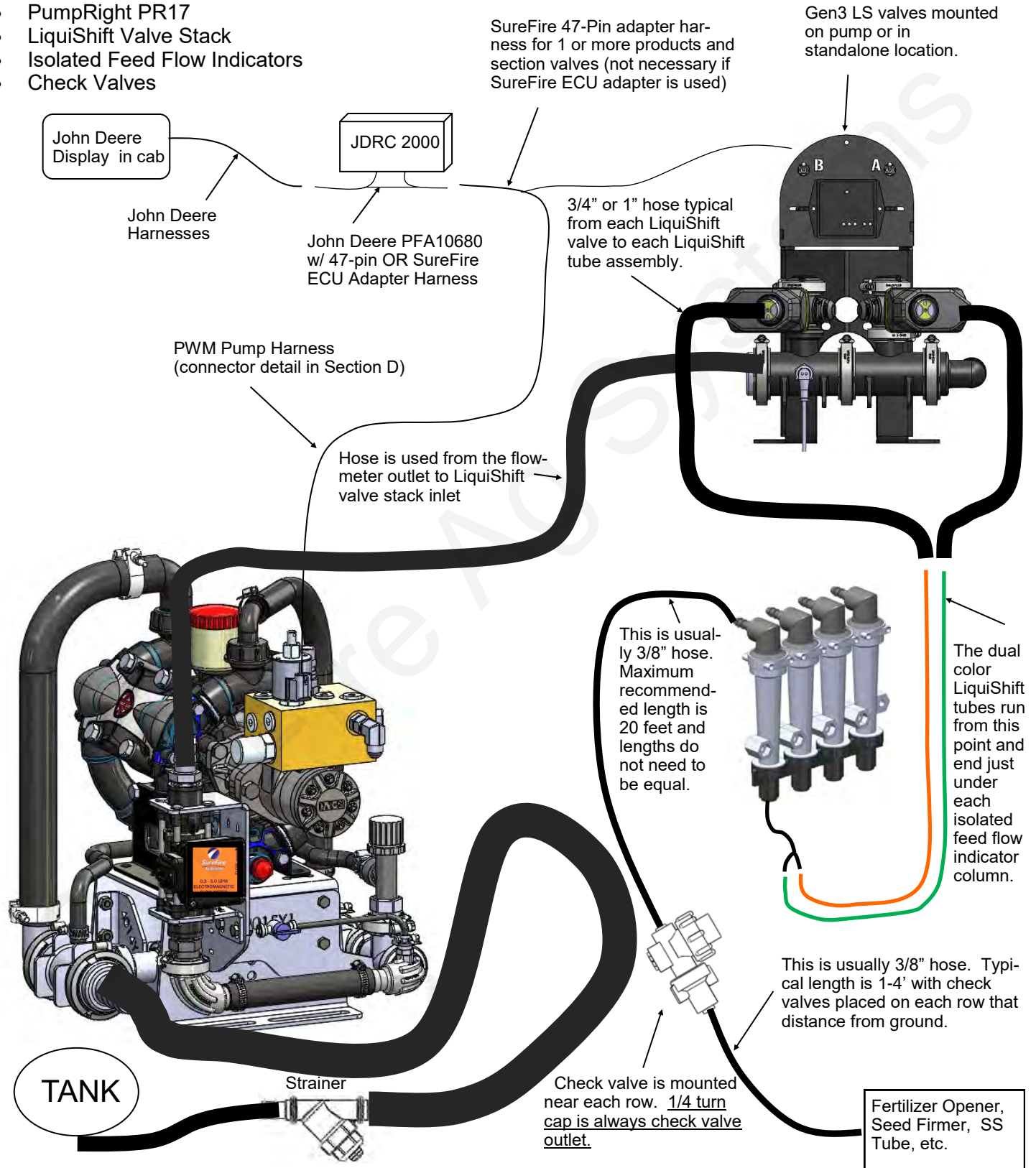

PR17 & PR30 Electromagnetic Flowmeter Kits

- 0.13 - 2.6 GPM Item Number 500-02-2082 (PR17)
- 0.3 - 5.0GPM Item Number 500-02-2085 (PR17)
- 0.6 - 13 GPM Item Number 500-02-2090 (PR17 & PR30)**
- 1.3 - 26 GPM Item Number 500-02-2095 (PR30)**

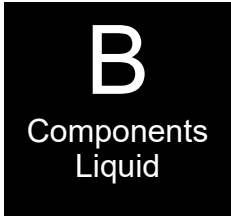

Kits include flowmeter, adapter harness, mounting bracket, hose barb fittings & hose clamps.

-Before doing any arc welding on the implement, unplug the cable to the flowmeter, or damage to the flowmeter may result.

-Do not power wash the flowmeter. High pressure spray directed at the back edge of the face plate or at the wire connector may allow water into the flowmeter electronics.

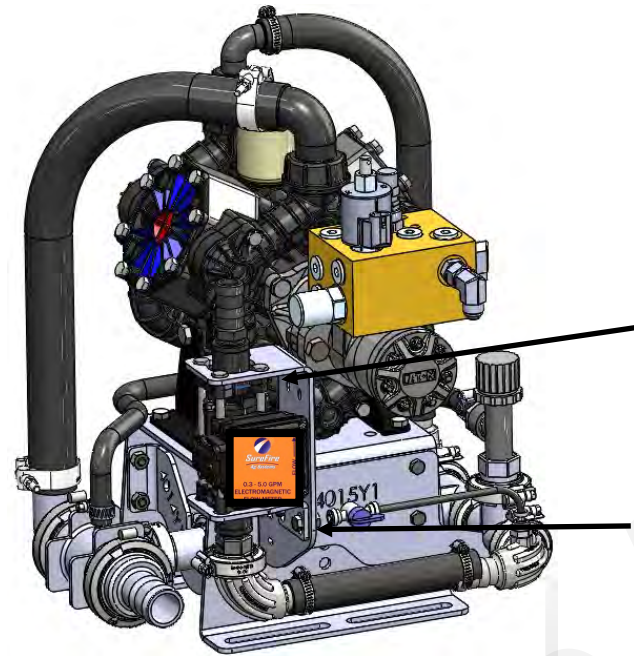

Mounting Bracket, 410-4015Y1 (QTY 1) (not used for PR40 and D250 Pump)

Mounting Bracket, 400-3826Y1 (QTY 1) (not used for PR40 and D250 Pump)

Amp SuperSeal 3-pin connector
Use adapter 201-17842
to connect to 3-pin MP harness

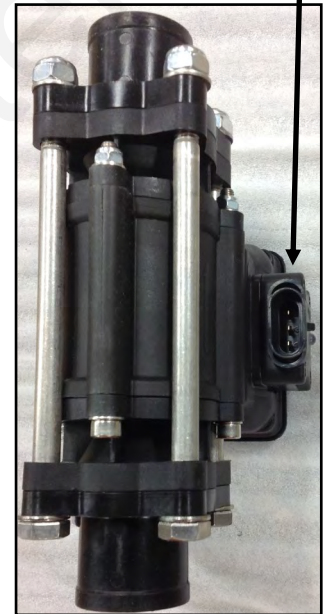

Troubleshooting Tip:



Remove red guard to reach pins. Be careful so you don't break red side keepers.

3-pin MP Tower A- Signal B- 12V Power C- Ground (See the next page for more flowmeter tips)
3-pin AMP SuperSeal 1- Ground 2- 12V Power 3- Signal

Electromagnetic flowmeters are superior to traditional turbine flowmeters in two basic ways. First, they have no moving parts. There are no wear items or potential for contaminants to jam a spinning turbine.

Second, electromagnetic flowmeters detect the flow by electrically measuring the velocity of the liquid, which makes them independent of viscosity or density of the fluid measured. They are extremely accurate using the standard calibration number. **SureFire still recommends you perform a catch test to verify the system is properly installed and configured.**

Flowmeter Model	Pulses per gallon	FPT Size	Hose Barb In kit
0.13 - 2.6 GPM	3000	3/4"	1"
0.3 - 5 GPM	3000	3/4"	1"
0.6 - 13 GPM	2000	3/4"	1"
1.3 - 26 GPM	2000	1"	1"

The flowmeters will accurately read higher than the rated range.

Earlier model flowmeters (meters with white labels with black text) have different calibration numbers. The flow cal number (pulses per gallon) is printed on the serial number sticker on the side of the flowmeter.

PR40 & D250 Electromagnetic Flowmeter Kit

2.6 - 53 GPM Item Number 500-02-2080

Kits include flowmeter, adapter harness, mounting bracket, hose barb fittings & hose clamps.

B

Components
Liquid

-Before doing any arc welding on the implement, unplug the cable to the flowmeter, or damage to the flowmeter may result.

-Do not power wash the flowmeter. High pressure spray directed at the back edge of the face plate or at the wire connector may allow water into the flowmeter electronics.

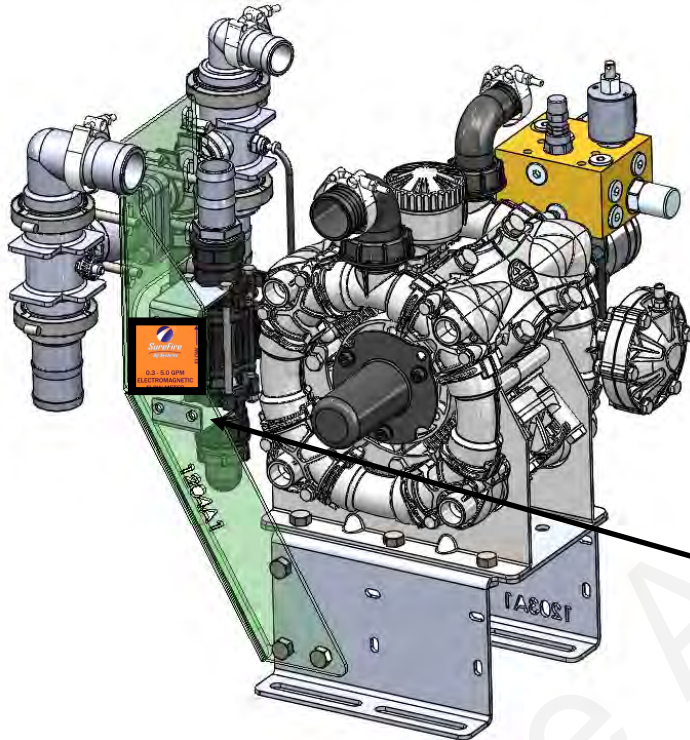

Mounting Bracket, 400-3335Y1 (QTY 2) (used for PR40 and D250 Pump only)

Amp SuperSeal 3-pin connector
Use adapter 201-17842
to connect to 3-pin MP harness

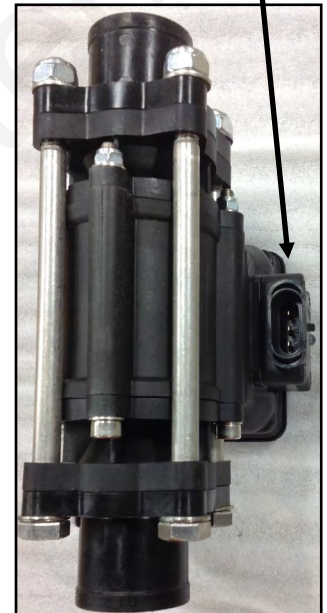

1 2 3

Remove red guard to reach pins. Be careful so you don't break red side keepers.



Troubleshooting Tip:

3-pin AMP SuperSeal 1- Ground 2- 12V Power 3- Signal

Power to Ground should be 12 volts.

Signal to Ground should be 4.5 to 5 volts

Do Tap Test between Signal and Ground to test harnessing.

3-pin MP Tower A- Signal B- 12V Power C- Ground

Additional Tip:

If flowmeter is not reading and the harnessing has checked out OK with voltage readings and tap test, try cleaning the inside tube of flowmeter with warm soapy water and a soft brush. Sometimes, a film builds up on the electrodes.

Flowmeter Model (black meter with orange label)	JDRC 2000 Flow Calibration	FPT Size	Hose Barb In kit
2.6—53 GPM	2000	1-1/4"	1-1/2"
1.3—26 GPM	2000	1"	1"

The flowmeters will accurately read higher than the rated range.

Earlier model flowmeters (meters with white labels with black text) have different calibration numbers. The flow cal number (pulses per gallon) is printed on the serial number sticker on the side of the flowmeter.

Section Valves and LiquiShift Valves

B

Components
Liquid



105-100PLG (alternate
105-100PLG025 includes 1/4" pipe
thread for gauge)

105-100075BRB90

Note: Ensure back-side port is
capped prior to use

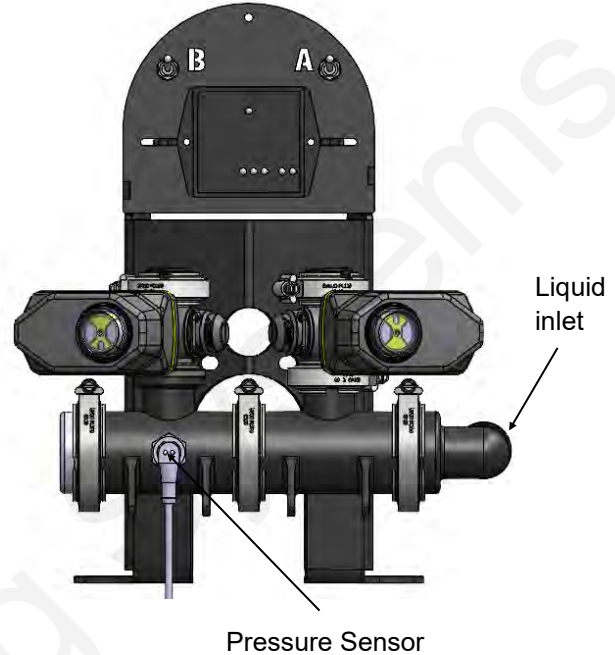
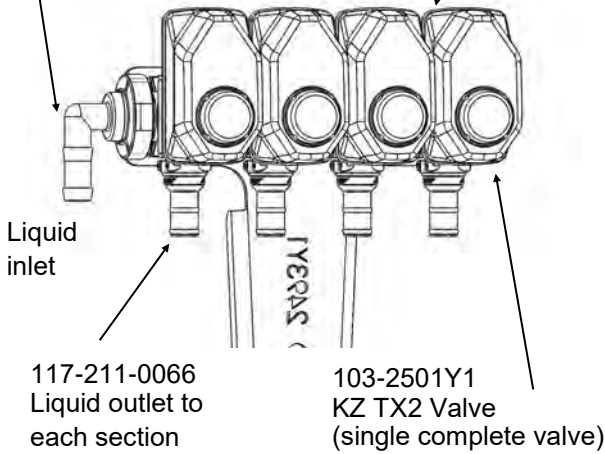

Additional Parts:

1" Gasket 105-100G-H
1" Clamp 105-FC100

How section valves work

Section valves can be assembled into groups with a common inlet to control flow to each section. Common assemblies use up to 5-6 valves, however, more can be used where practical. Many alternate fittings can be used to accommodate different hose sizes and configurations.

The valves have a 3-pin weather pack electrical connector. This has a power, ground, and switched wire. The power measured to ground should have 12 volts when the controller is on. The switched wire will have 12 volts to turn the valve on, and 0 volts to turn the valve off.

Wiring Connector:

Pin A—Red, 12 Volts +
Pin B—Black, Ground -
Pin C—White, Signal
12V=on ; 0V=off

Mounting Hardware:

2 Valve Bolt Kit
384-1100
Mounting Bracket
400-2493Y1

How LiquiShift Works

LiquiShift is a two-valve manifold specifically built and controlled to provide the operator a very wide flow range for variable rate application. It is valuable for variable rate prescription application or high-speed implements, or variable rate between different fields. LiquiShift has an A and B valve that are opened based on the system pressure.

The valves themselves are identical to a regular section valve (KZ TX2) and have a 3-pin weather pack electrical connector.

The A Valve is connected to a set of smaller metering tubes. The B Valve is connected to a set of larger metering tubes. The LiquiShift controller automatically turns on the A valve, or the B valve, or both valves depending on the flow required.

Gen3 LiquiShift systems on the JDRC are available with up to 16 sections depending on the implement.

See also: [Gen3 LiquiShift Manual \(396-4608Y1\)](#)
[Gen2 LiquiShift Manual \(396-4063Y1\)](#)

Pressure Sensor

3 Wire Sensor with 2" Manifold x 1/4" MPT Fitting

Item Number 520-00-055100

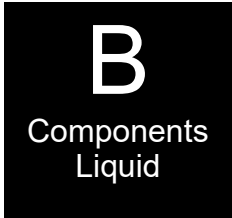

The JDRC 2000 has the ability to show fertilizer system pressure on the display. The pressure sensor is most often mounted on electric section valves when used in PumpRight systems. The pressure sensor is a 100 psi, 0—5 volt, 3-wire type sensor for compatibility with the JDRC 2000. The sensor has a 1/4" MPT fitting.

The user can select to display the pressure on the John Deere display. The pressure sensor is very helpful to optimize system performance and troubleshoot any issues. Pressure alarms or limits can be set on the Deere display in the cab, but are typically not used on standard fertilizer application systems.

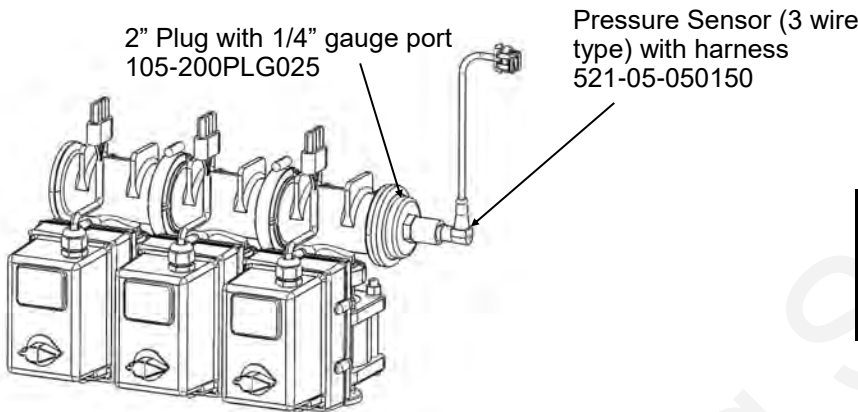

JDRC 2000:
 Pressure Sensor Type: Custom
 Pressure Calibration: 50 mv/psi

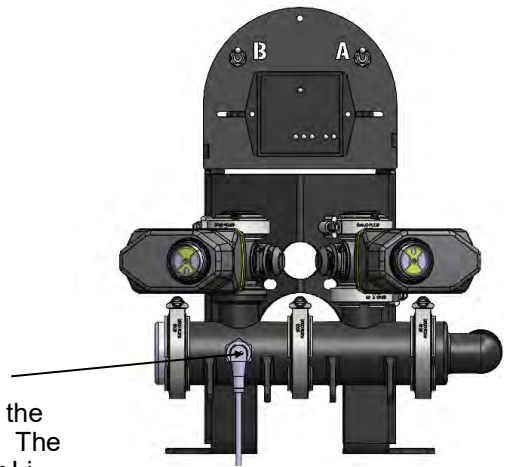
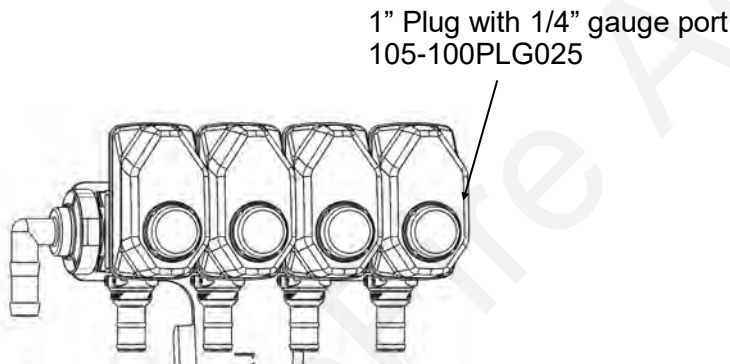

Pressure Sensor for LiquiShift is mounted at the base of the valve stack. The same sensor is used for LiquiShift and displayed on the JDRC 2000 Run screen.

Pressure Sensor Hose Tap Kits

When electric section valves or LiquiShift is **not** used in the fertilizer system, the best location to install the pressure sensor is in the hose after it leaves the flowmeter. To use these kits, order the correct kit for your hose size. Then also order the kit above that includes the 2" Manifold x 1/4" MPT fitting.

- 3/4" Hose Pressure Tap 520-00-055800
- 1" Hose Pressure Tap 520-00-055850
- 1 1/2" Hose Pressure Tap 520-00-055900

Pump Priming and Air Bleed Valve

An air bleed valve is included with each pump to aid in system priming. It is shipped in the pump accessories bag and must be installed during system installation.

For best results, close the recirculation knob and open the air bleed valve when priming the pump.

Why use an air bleed valve:

Most fertilizer systems are equipped with a 4 or 10 lb. check valve on the end of each hose delivering fertilizer to the ground. These valves do not let air escape from the system, unless it is pressurized. PumpRight liquid pumps are not good air compressors. Therefore, the pump can struggle to prime due to air trapped on the outlet side of the pump.

The air bleed valve is a small 1/4" valve that when opened lets air escape from the pump outlet at zero pressure. Open until liquid comes out and then close the valve.

Be sure the air bleed valve tube does not become plugged with dirt or it will not allow air to bleed.

How to install the air bleed valve:

Remove the 1/4" plug from the quick connect fitting on the pump outlet side (see pictures below). Next, insert the 1/4" tubing in the quick connect fitting. Run the 1/4" tubing to an easily accessible spot on your equipment. Next, cut the tubing and push the 1/4" valve onto the tubing. Finally, run the tubing to a low location where any fertilizer that escapes will run on the ground.

Be sure the air bleed valve tube does not become plugged with dirt or it will not allow air to bleed.

PR17 & PR30

Attach 1/4" tubing to 1/4" QC on the 90 deg HB sweep gauge port

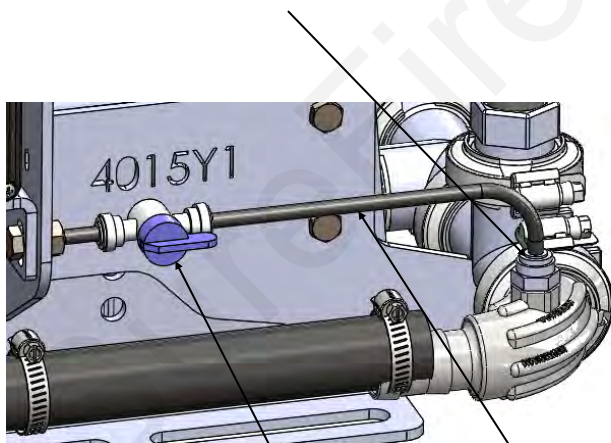

1/4" air bleed valve

1/4" Tubing

PR40 & D250

Attach 1/4" tubing to 1/4" QC on back side of 1" x 2" tee on outlet side of pump

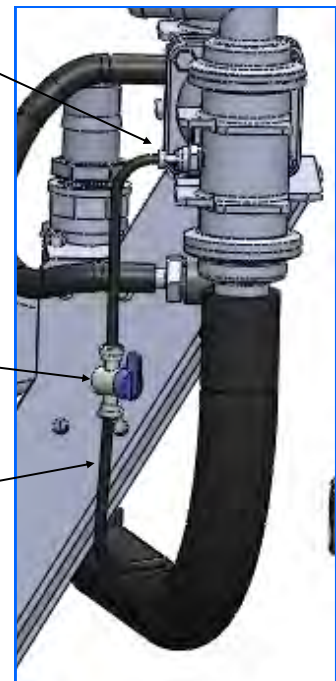

1/4" air bleed valve

Recirculation & Agitation

A recirculation valve is standard on all 4 PumpRight models outlet plumbing assemblies.

B

Components
Liquid

For best results, close the recirculation knob when priming the pump.

Opening the recirculation knob will NOT lower the pressure required to push the product to the rows.

How Recirculation Works:

When running a PumpRight pump at less than 20% of it's maximum flow, it sometimes improves system stability to allow the pump to run faster. Opening the recirculation valve diverts some pump flow before the flowmeter, causing the pump to run faster. The application rate is still measured by the flowmeter and everything that passes through the flowmeter is applied to the ground. If the pump is surging at a low flow rate, open the recirculation regulation valve until the pump runs smoothly. *Start with a quarter to a half turn.*

OPENING THE VALVE LOWERS THE MAXIMUM RATE THAT CAN BE APPLIED TO THE GROUND. Close the valve if a higher rate is required.

How to modify for tank agitation:

If tank agitation is required, the recirculation valve can be re-plumbed to divert flow to the tank. All that is required is to remove the 1/2" recirculation hose from the pump. Then replace the 3/8" MPT x 1/2" HB on the inlet side of the pump with a 3/8" plug which is included in your PumpRight accessories bag. Finally, install a longer 1/2" hose from the recirculation valve back to the tank.

PR17 & PR30

Recirculation Regulation Valve,
102-23520-3/4
Start with a quarter to a half turn.

Recirculation hose attaches to back of 2" x 1" tee
on pump inlet

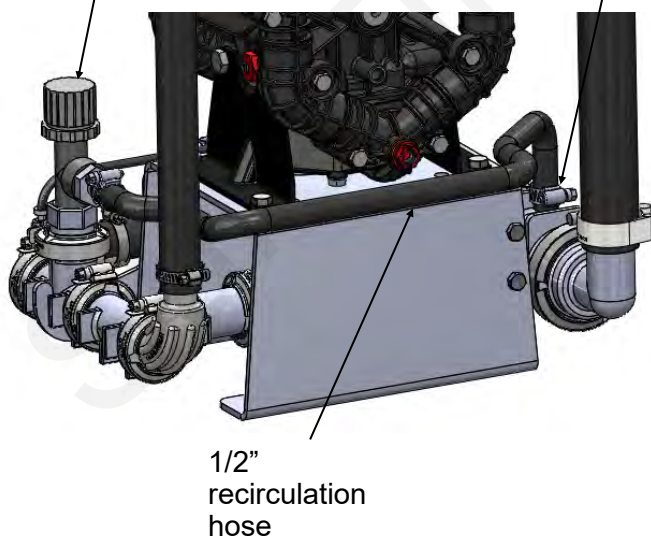

PR40 & D250

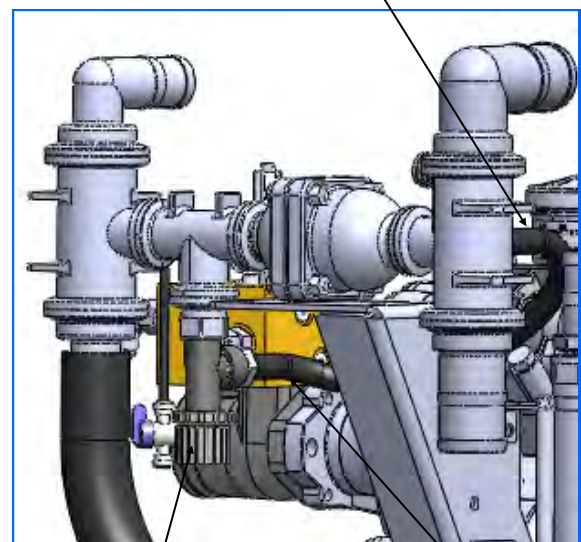

Recirculation Regulation
Valve, 102-23520-3/4

1/2" recirculation
hose

Product Distribution

To assure proper and even distribution to each row, the product being applied must be metered to each individual row. This metering is done by one of the 3 following methods which create back pressure so an equal amount of liquid is applied to each row:

1. A metering orifice may be placed in the check valve cap in the line that leads to each row. (See photo on page 13)
2. A dual metering tube kit with dual check valves may be used. (See pages 17-20)
3. A LiquiShift valve stack may be used that automatically selects which metering tube to use based on system pressure.

B
Components
Liquid

Floating Ball Flow Indicator & Manifold System

Flow indicators give a clear visual signal that a fertilizer system is working. These indicators use an o-ring and wire clip connection to snap together in any configuration necessary.

SureFire has simple tee brackets and U-bolts that will mount these to a variety of bar sizes.

Two main types of flow indicators are used. On 30" row spacing, the low flow column with 1/4" push to connect outlet is recommended for rates under 10 GPA. For rates over 10 GPA the full flow column with 3/8" hose barb outlet is preferred.

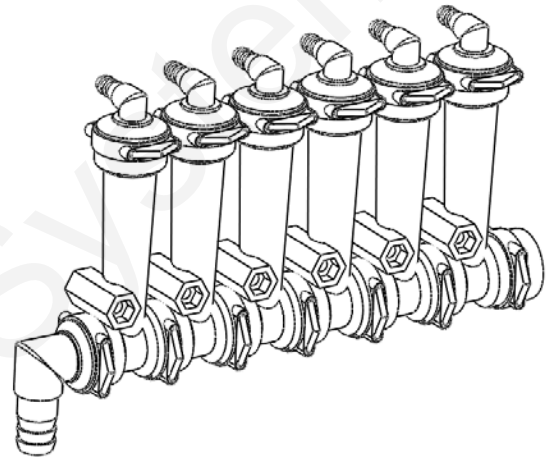

Parts List

Complete Columns

701-20460-950	Single Full Flow Column with 3/8" HB - 90 Degree Outlet
701-20460-940	Single Full Flow Column with 3/8" QC - 90 Degree Outlet
701-20460-960	Single Full Flow Column with 1/2" HB - 90 Degree Outlet
701-20460-935	Single Low Flow Column with 3/8" QC - 90 Degree Outlet
701-20460-920	Single Low Flow Column with 1/4" QC - 90 Degree Outlet

Fittings

701-20503-00	ORS x 3/4" HB - Straight
701-20511-00	ORS x 3/8" HB - 90 Degree
701-20512-00	ORS x 1/2" HB - 90 Degree
701-20513-00	ORS x 3/4" HB - 90 Degree
701-20516-00	ORS x 1/4" QC - 90 Degree
701-20517-00	ORS x 3/8" QC - 90 Degree
701-20518-00	ORS x 1/4" FPT - 90 Degree
701-20519-00	ORS x 1/4" FPT - Straight
701-20520-00	ORS Male x ORS Female - 90 degree
701-20521-00	Wilger End Cap
701-20523-00	ORS Male x ORS Female x 3/8" FPT - Isolator
701-20525-00	ORS Male x ORS Male x 1" FPT - Tee

Service Parts Only

701-20460-02	Wilger Flow Indicator Ball Retainer
701-20460-03	FKM O-Ring for indicator body & fittings
701-20460-04	Wilger Lock U-clip
701-20460-05	Flow Indicator Ball - 1/2" SS Ball
701-20460-06	Flow Indicator Ball - Maroon Glass
701-20460-07	Flow Indicator Ball - Red Celcon
701-20460-08	Flow Indicator Ball - Green Poly
701-20460-09	Flow Indicator Ball - Black Poly
701-20460-15	Viton O-Ring for column & fittings
701-40225-05	Viton O-Ring for Orifice

Brackets & U-Bolts

400-1037A1	3-6 Row Bracket
400-3155Y1	7-12 Row Bracket
400-2011A1	White Backer Plate for 3-6 Row Bracket
400-2010A1	White Backer Plate for 7-12 Row Bracket
400-1315A2	Flow Indicator Bracket, 6-8 in wide hitch mount

Floating Ball Flow Indicators- Full Flow Column (mostly 3/8" HB)

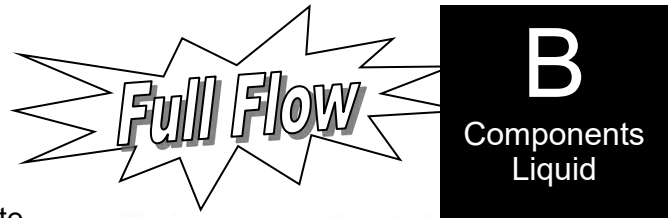

The full flow column is typically used with rates over 10 GPA on 30" rows. For rates less than 10 GPA SureFire recommends the low flow columns with 1/4" push to connect outlet fittings.

The full flow columns are most often assembled with 3/8" hose barb outlets. See the low flow info below for the difference between full and low flow columns.

Full Flow Indicators w/ 3/8" Hose Barb Outlet

Column Flow (GPM):	.05-2.70 GPM
Equivalent Application Rate On 30" Rows at 6 MPH:	2-70 GPA

Ball Selection for 30" Rows

GPM	GPA	Ball
.05-.18	2-6	Green Plastic*
.09-.30	3-10	Red Plastic*
.31-.72	10-20	Maroon Glass
.40-2.1	13-70	Stainless Steel (1/2")

*Plastic balls may float on heavier fertilizers, such as 10-34-0. SureFire recommends using the low flow column for these flow rates.

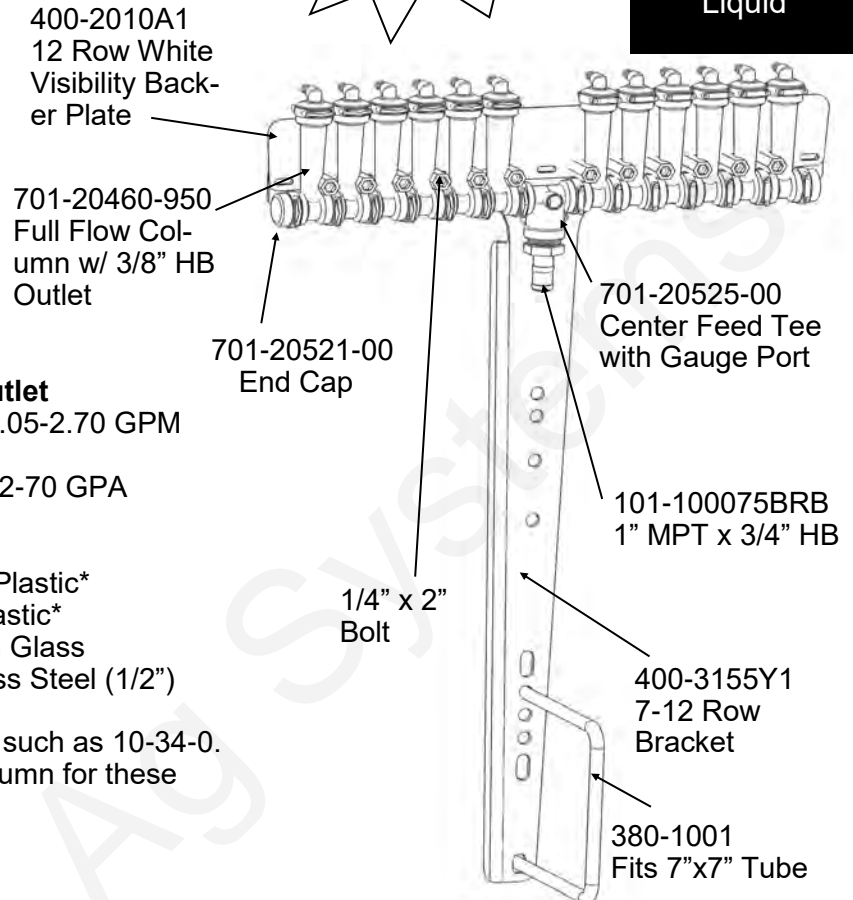

Low Flow Column (mostly 1/4" QC or 3/8" QC)

The low flow column has a smaller internal diameter. This means a heavier ball can be used to monitor a smaller flow.

SureFire uses the low flow columns with 1/4" push to connect outlet fittings. The flow capability of 1/4" tubing and the low flow column are a great pair for rates on 30" rows under 10 GPA.

Externally, the low flow column can only be identified by "Low Flow" molded into one side of the column. All the same fittings work with low flow and full flow columns.

Low Flow Indicators w/ 1/4" Push to Connect Outlet

Column Flow (GPM):	.03-.30 GPM
*** Low Flow Column with 3/8" hose barb	.03 - .70 GPM
Equivalent Application Rate On 30" Rows at 6 MPH (1/4" QC):	1-10 GPA

Ball Selection for 30" Rows

GPM	GPA	Ball
.03-.09	1-3	Green Plastic*
.05-.14	2-4	Red Plastic*
.10-.18	3-6	Maroon Glass
.15-.70	5-10	Stainless Steel (1/2")

*These balls may float on heavier fertilizers, such as 10-34-0. Use Maroon Glass in this case.

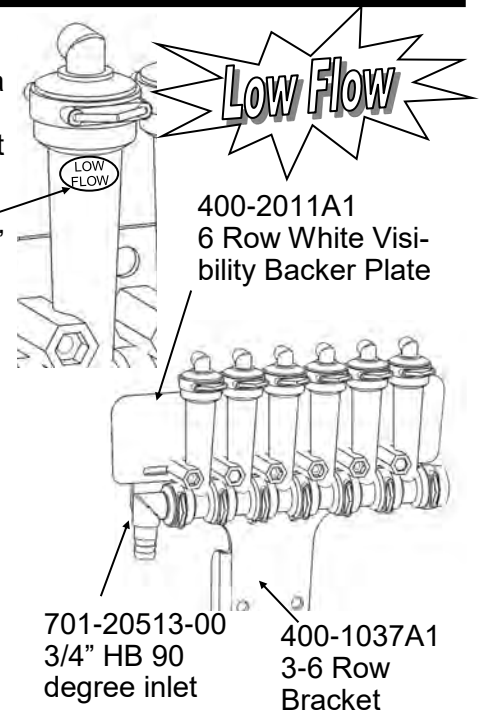

Check Valves

10 lb check valve with 3/8" hose barbs

B
Components
Liquid

The recommended check valve for most **PumpRight** installations is the 10 lb check with 3/8" hose barbs. This works with 3/8" rubber hose which SureFire recommends for most applications over 10 GPA on 30" rows. The recommended minimum system operating pressure for this check is 20 psi, to ensure all checks open fully.

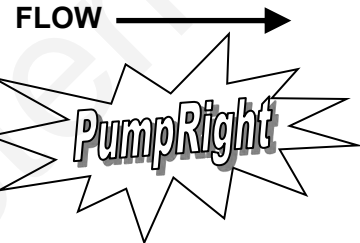
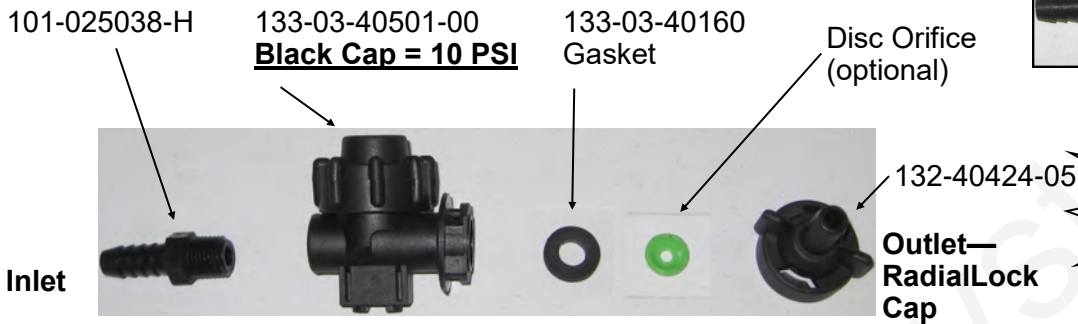

4 lb check valve with 1/4" quick connect fittings

4 lb check valves are typically used with **electric pump systems**. SureFire recommends this valve for use with 1/4" tubing applying up to 10 GPA on 30" rows. The recommended minimum system operating pressure for this check is 10 psi, to ensure all checks open fully.

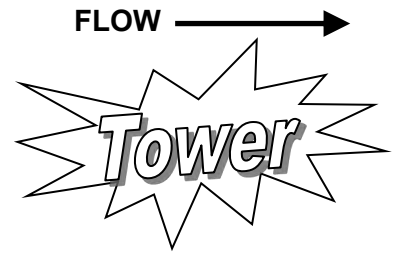
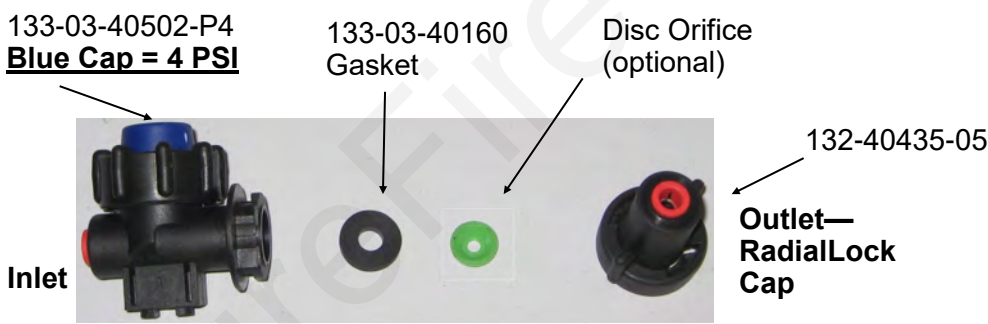

Special Purpose Check Valve Assemblies

Assembly Part Number	Description	Suggested Uses (30" rows)
136-10-04QC04QC	1/4" QC x 1/4" QC 10 lb	< 10 GPA with PumpRight & 1/4" Tubing
136-10-06QC06QC	3/8" QC x 3/8" QC 10 lb	With 3/8" tubing plumbing
136-04-06HB06HB	3/8" HB x 3/8" HB 4 lb	> 10 GPA with Electric Pumps
136-04-08HB08HB	1/2" HB x 1/2" HB 4 lb	> 50 GPA with PumpRight
136-10-08HB08HB	1/2" HB x 1/2" HB 10 lb	> 50 GPA with PumpRight

Colored Disc Orifice Chart for 30" rows

Download the SureFire Flow Calculator App for iPad

B

Components
Liquid

30" Spacing

Orifice Color (Approx Size)	PSI	Gal/Min 28-0-0	MPH						
			4.0	4.5	5.0	5.5	6.0	6.5	7.0
Pink (24)	10	0.033	1.62	1.44	1.30	1.18	1.08	1.00	0.93
	20	0.046	2.28	2.02	1.82	1.66	1.52	1.40	1.30
	30	0.057	2.80	2.49	2.24	2.04	1.87	1.73	1.60
	40	0.065	3.24	2.88	2.59	2.36	2.16	1.99	1.85
	50	0.073	3.64	3.23	2.91	2.64	2.42	2.24	2.08
	60	0.081	3.99	3.54	3.19	2.90	2.66	2.45	2.28
Gray (30)	10	0.050	2.50	2.22	2.00	1.82	1.66	1.54	1.43
	20	0.072	3.55	3.15	2.84	2.58	2.37	2.18	2.03
	30	0.088	4.34	3.85	3.47	3.15	2.89	2.67	2.48
	40	0.101	4.99	4.44	4.00	3.63	3.33	3.07	2.85
	50	0.112	5.56	4.95	4.45	4.05	3.71	3.42	3.18
	60	0.124	6.13	5.45	4.91	4.46	4.09	3.77	3.50
Black (35)	10	0.070	3.46	3.08	2.77	2.52	2.31	2.13	1.98
	20	0.098	4.86	4.32	3.89	3.54	3.24	2.99	2.78
	30	0.120	5.96	5.30	4.77	4.33	3.97	3.67	3.40
	40	0.139	6.88	6.11	5.50	5.00	4.58	4.23	3.93
	50	0.156	7.71	6.85	6.17	5.61	5.14	4.74	4.41
	60	0.170	8.41	7.48	6.73	6.12	5.61	5.18	4.81
Brown (41)	10	0.094	4.64	4.13	3.71	3.38	3.10	2.86	2.65
	20	0.132	6.53	5.80	5.22	4.75	4.35	4.02	3.73
	30	0.162	8.02	7.13	6.41	5.83	5.34	4.93	4.58
	40	0.187	9.24	8.22	7.39	6.72	6.16	5.69	5.28
	50	0.209	10.34	9.19	8.27	7.52	6.89	6.36	5.91
	60	0.228	11.30	10.05	9.04	8.22	7.53	6.95	6.46
Orange (46)	10	0.119	5.91	5.26	4.73	4.30	3.94	3.64	3.38
	20	0.169	8.37	7.44	6.69	6.08	5.58	5.15	4.78
	30	0.207	10.25	9.11	8.20	7.45	6.83	6.31	5.86
	40	0.239	11.83	10.51	9.46	8.60	7.88	7.28	6.76
	50	0.267	13.23	11.76	10.58	9.62	8.82	8.14	7.56
	60	0.293	14.50	12.89	11.60	10.55	9.67	8.92	8.29
Maroon (52)	10	0.149	7.36	6.54	5.89	5.35	4.91	4.53	4.21
	20	0.210	10.38	9.23	8.31	7.55	6.92	6.39	5.93
	30	0.257	12.70	11.29	10.16	9.24	8.47	7.82	7.26
	40	0.296	14.67	13.04	11.74	10.67	9.78	9.03	8.39
	50	0.332	16.43	14.60	13.14	11.95	10.95	10.11	9.39
	60	0.363	17.96	15.96	14.37	13.06	11.97	11.05	10.26
Red (63)	10	0.218	10.78	9.58	8.62	7.84	7.18	6.63	6.16
	20	0.307	15.20	13.51	12.16	11.05	10.13	9.35	8.69
	30	0.376	18.62	16.55	14.89	13.54	12.41	11.46	10.64
	40	0.435	21.51	19.12	17.21	15.64	14.34	13.24	12.29
	50	0.486	24.05	21.38	19.24	17.49	16.03	14.80	13.74
	60	0.532	26.33	23.40	21.06	19.15	17.55	16.20	15.04
Blue (80)	10	0.351	17.39	15.46	13.91	12.65	11.59	10.70	9.94
	20	0.496	24.57	21.84	19.66	17.87	16.38	15.12	14.04
	30	0.608	30.09	26.75	24.08	21.89	20.06	18.52	17.20
	40	0.702	34.74	30.88	27.79	25.26	23.16	21.38	19.85
	50	0.785	38.86	34.54	31.08	28.26	25.90	23.91	22.20
	60	0.859	42.53	37.81	34.03	30.93	28.36	26.18	24.31
Yellow (95)	10	0.506	25.06	22.27	20.05	18.22	16.70	15.42	14.32
	20	0.715	35.39	31.46	28.32	25.74	23.60	21.78	20.23
	30	0.876	43.37	38.55	34.69	31.54	28.91	26.69	24.78
	40	1.009	49.94	44.39	39.95	36.32	33.29	30.73	28.54
	50	1.133	56.07	49.84	44.86	40.78	37.38	34.51	32.04
	60	1.239	61.33	54.51	49.06	44.60	40.88	37.74	35.04
Green (110)	10	0.686	33.95	30.18	27.16	24.69	22.63	20.89	19.40
	20	0.973	48.19	42.83	38.55	35.04	32.12	29.65	27.53
	30	1.186	58.70	52.18	46.96	42.69	39.13	36.12	33.54
	40	1.372	67.90	60.35	54.32	49.38	45.27	41.78	38.80
	50	1.531	75.78	67.36	60.63	55.12	50.52	46.64	43.30
	60	1.681	83.23	73.98	66.58	60.53	55.49	51.22	47.56

PumpRight Pressure Recommendations (with 10 lb check valves):

- Minimum 20 PSI
- Maximum 80 PSI

Tower Electric Pump Pressure Recommendations (with 4 lb check valves):

- Minimum 10 PSI
- Maximum 30 PSI

Chart is for 28-0-0 Fertilizer @ 70°

- Heavier fertilizers (like 10-34-0) will have 5-15% less flow than chart indicates for a certain pressure
- Cold fertilizers will cause system pressure to increase at a given application rate.
- Tower Electric Pump Systems will have reduced flow and increased electrical current draw due to cold fertilizer increasing operating pressure. **Use the largest orifice possible for cold weather operation.**

Colored Disc Orifice assemblies under the check valve cap in most cases. (Drop the orifice with the hole down into the cap, then put the gasket on top of it.) The orifice can also be installed in a manifold (common on grain drills).

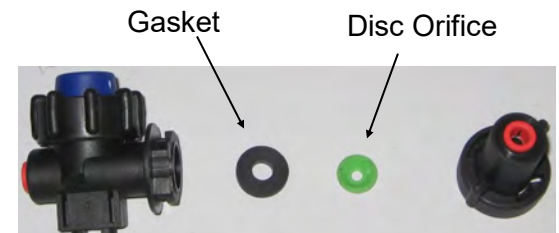

FLOW → 1/4 Turn Cap is Outlet

Dual Metering Tube Plumbing Kits with Dual Check Valve

For more information, read [Navigating the Metering Tube Maze](#) or [Metering Tube / LiquiShiftTube Charts](#).

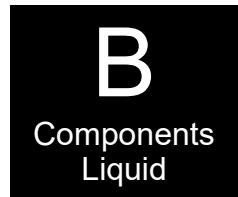

SCAN

for "What is Metering Tube?" video

SureFire dual metering tube plumbing kits are a great way to apply fertilizer.

These plumbing kits will contain everything you need to distribute fertilizer from the flowmeter outlet down to the ground application device of your choice (not included).

These instructions will show you where all the pieces go. It will provide guidance on how much metering tube to use. There are some optional fittings included in each plumbing kit. These instructions will show you where and why you'd want to use the optional pieces.

The dual check valve assembly is a key piece in the dual metering tube design. In addition to a check valve to stop fertilizer from draining when the system is shut off, **each check valve has an on/off valve on top of it. These on / off valves allow the operator to turn on only tube 1, only tube 2, or both tube 1 and 2.** This provides for three different application ranges, which is especially helpful when using a fertilizer which has a highly variable viscosity based on temperature changes or when changing rates from field to field.

Dual Advantage of Dual Metering Tube

Metering tube provides a larger passage way diameter than a comparable orifice. For a 5 GPA rate on 30" rows, a size 0.046" orifice would be used. For the same rate a 0.110" meter tube that is 8' long would be used. This 8' tube with more than twice the diameter creates a fertilizer system resistant to plugging while providing excellent row to row distribution.

By using two metering tubes, the fertilizer system can handle a wider range of rates and provide the proper system pressure as the fertilizer properties change due to temperature, mixtures and other factors.

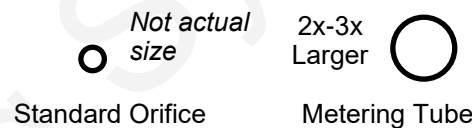

Field Operation of Dual Metering Tube - Dual Check Valve System

The dual metering tube allows for three application rate ranges. Some fertilizers have a widely variable viscosity. Therefore, based on temperature, tank mixing and fertilizer batch, the best tube to use will change.

SureFire recommends you start with the larger tube ON only. This is the middle size and is a good starting point. Conduct a test using the Nozzle Flow Check with fertilizer to determine your system pressure. If pressure is below 15 psi, some check valves may not open and row to row distribution will be uneven.

Start with larger tube ON, smaller tube OFF:

- **Pressure below 15 PSI: Turn larger tube OFF and smaller tube ON.**
- **Pressure over 50 PSI: Turn BOTH tubes ON.**

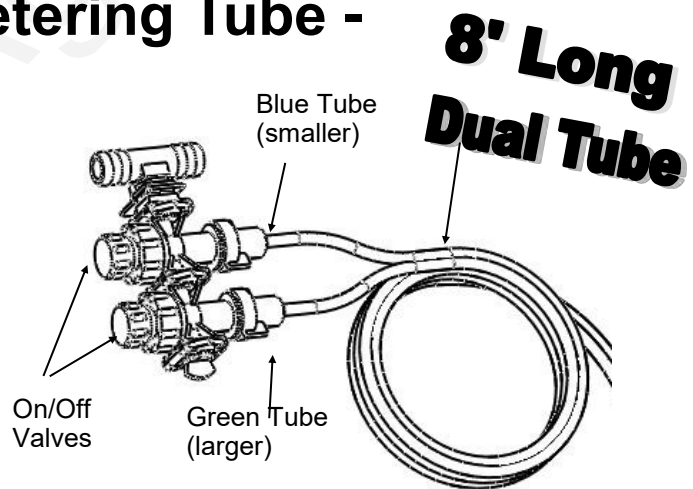

	GPA on 30" rows (approx, will vary)
Blue Tube	1.5 - 3
Green Tube	3 - 6
Blue & Green Tube	6 - 10
Minimum Recommended flow for Blue Tube (8 ft)	4 - 5 oz/min

Other tubes are available if needed for different application rates.

** Ultra Low Rate Application –For rates from 2-5 oz/min/row use a 12 foot length of metering tube. To calculate oz/min/row: $Oz/min/row = (GPA \times MPH \times spacing \text{ (inches)}) \div 46.4$



Dual Check Valve Plumbing Diagram

4 Row Planter Shown, add rows as necessary

136-04-200400, Dual 4 PSI check valve with 1/4" QC caps and 3/8" FPT inlet

101-075075038-HBT-M-W 3/4" HB x 3/4" HB x 3/8" MPT Tee

113-19-025025025 Y Divider - 1/4" QC

Dual Metering Tube - 8 feet long

101-038075-90-W, 3/8" MPT x 3/4" HB - 90 degree

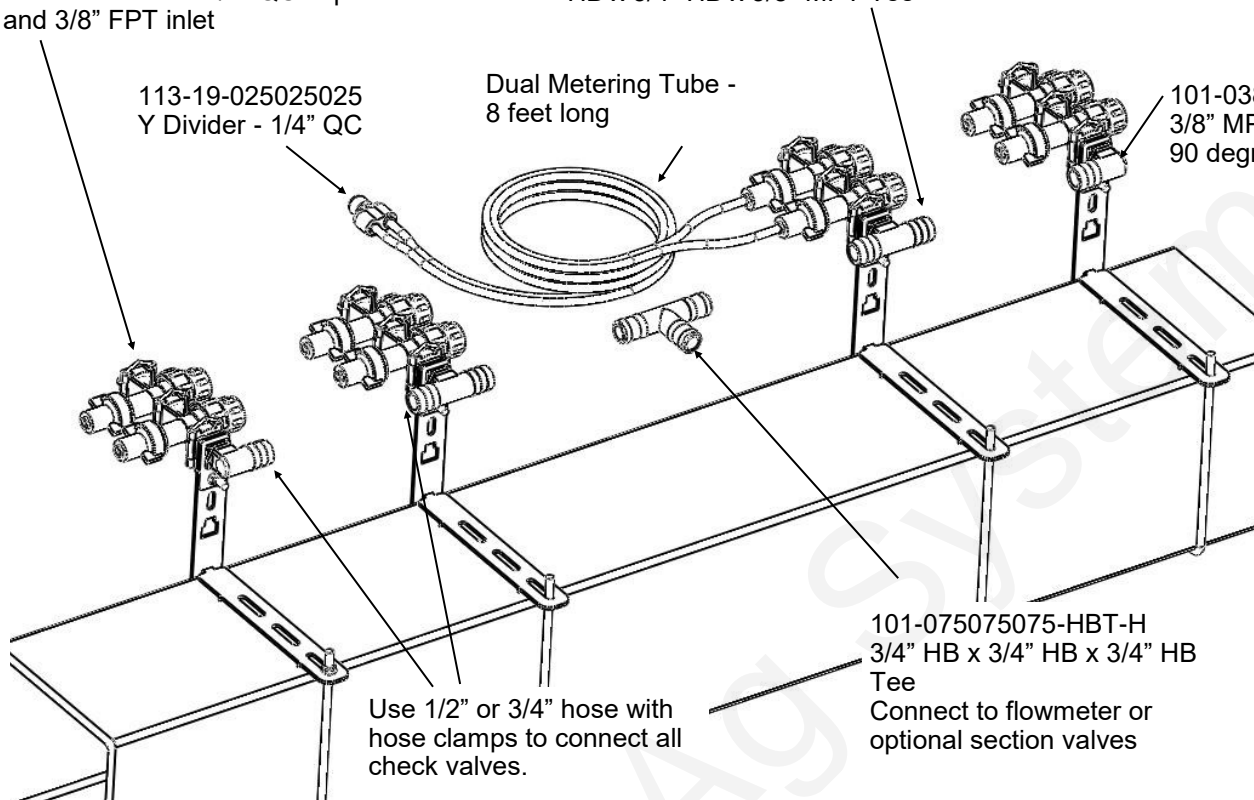

This is a general diagram showing the dual check valve assembly mounted on a planter toolbar. The check valve and bracket are very flexible in their mounting. The check valve can mount behind, directly over, or in front of the toolbar. The check valve can be put in the bracket facing up & down or sideways (shown). In addition the steel bracket could be rotated 90 degrees and clamp around the bar. The multiple slots in the bracket are used to mount to any tube 7x7 inches or smaller.

Sectional Plumbing Diagram with Dual Check Valves

12 Row Planter Shown

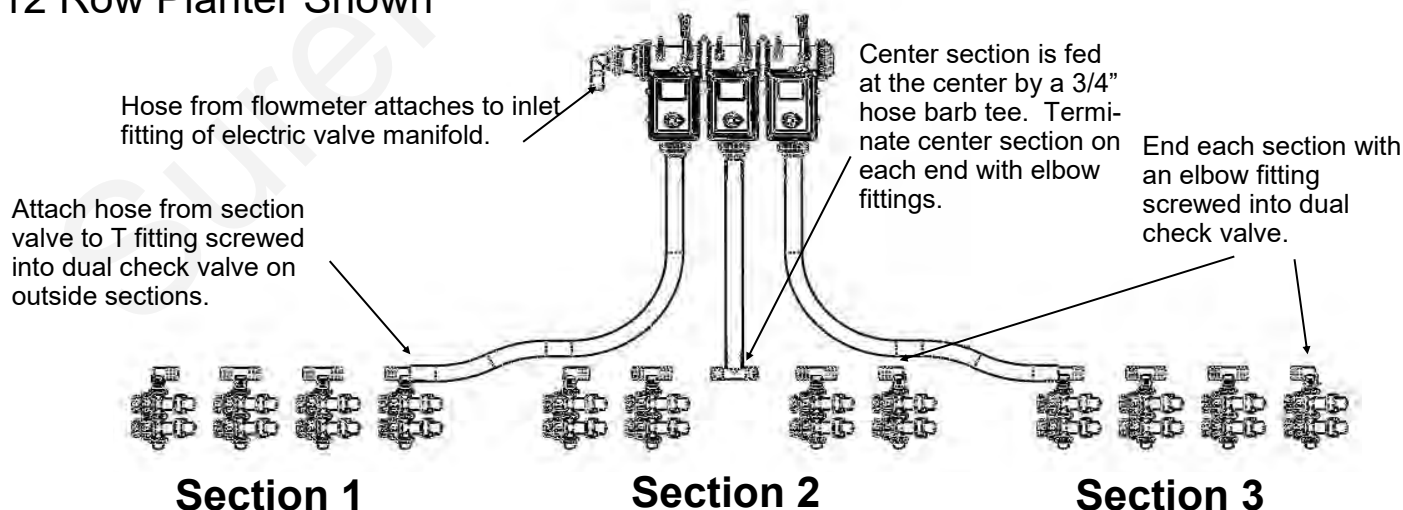

For a **2 section plumbing system**, omit the center section and plumb similar to the outside 2 sections.

Dual Check Valve Assembly Steps

B
Components
Liquid

Follow these steps to mount each check valve to the steel bracket.

1. Screw the 3/8" MPT x 3/4" HB tee or elbow into the check valve using blue thread sealer. Orient the hose barb to run the 3/4" hose down the planter toolbar.
2. Insert the check valve into the "C" notch in the end of the bracket, according to how you want the check valve to be mounted on your planter. Orient the wire clips up or to the side for easiest access.
3. Slide the small "C" clamp bracket around the check valve to lock it in place.
4. Install the 1/4" carriage bolt and flange nut to secure the "C" clamp plate around the check valve.
5. Now, mount the check valve on the bar. Hold the check valve and long bracket assembly on the toolbar. Slide the tab on the front of the short bracket into the upper or lower notch on the long bracket.
6. Slide the L bolt into the appropriate slots on the brackets for your tube size. Tighten the 1/4" flange nuts to hold the bracket in place.

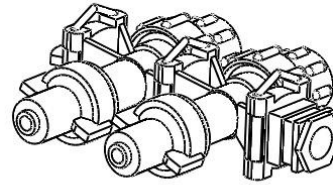

Clamp Bracket

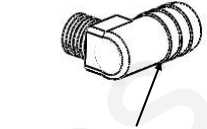
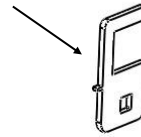

Elbow at end of section, Tee in mid-locations.

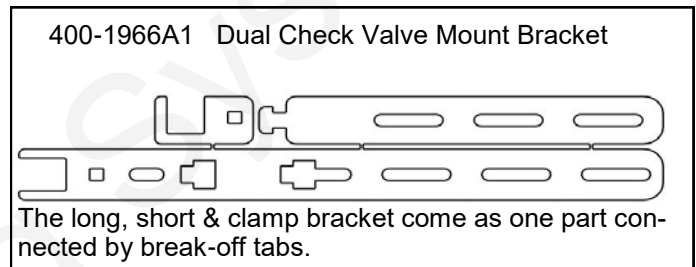

Check Valve Mounting Options

The dual check valve mounting bracket is very flexible to fit many different planter configurations. Three options are shown here to illustrate some of the possibilities.

Example 1. Use the long bracket on the top of a bar. The check valve is mounted vertically. The liquid supply hose is ran directly on the front side of the bar. The U-bolt is placed in slots to clamp on a 4x6 inch tube.

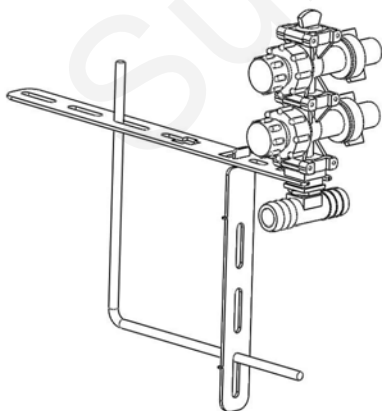

Example 2. Use the long bracket on the rear of a bar. The check valve is mounted over the top of the bar. The supply line would run above and behind the bar. The short bracket is placed in the notch to mount the check valve closer to the bar.

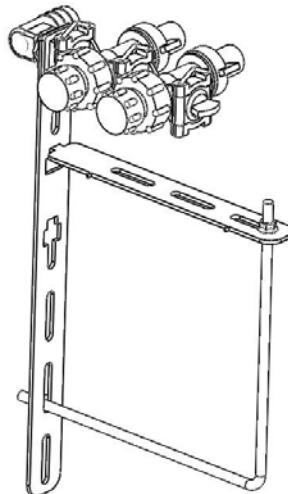

Example 3. Use the long bracket on the front of a 3x7 bar (vacuum tube on some planters). Mount the check valve hanging forward of the bar. The supply line will run directly over the bar. The excess bolt and bracket length can be cut off.

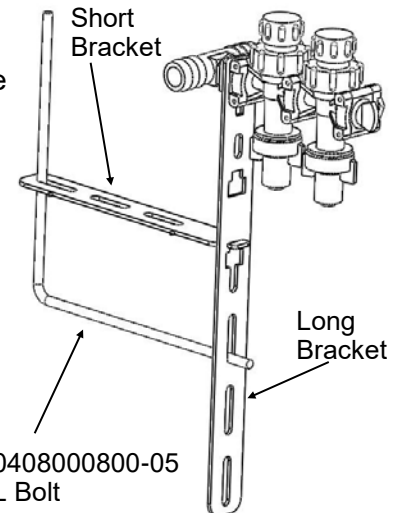

Connection to Keeton Seed Firmer, Rebounder Seed Covers or through thin wall stainless steel tubes

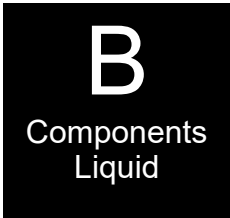

1. Mount the Keeton Seed Firmer or Rebounder Seed Cover.
2. Route the tube included in the above kit as instructed.
3. Attach the 1/4" tube to the 1/4" QC Y divider fitting.
4. Zip all tubing to the planter and row unit in as many locations as possible.

For thin wall stainless steel tubes, you can push the 1/4" black tubing all the way through the stainless steel tube so fertilizer will run directly from the tubing onto the ground.

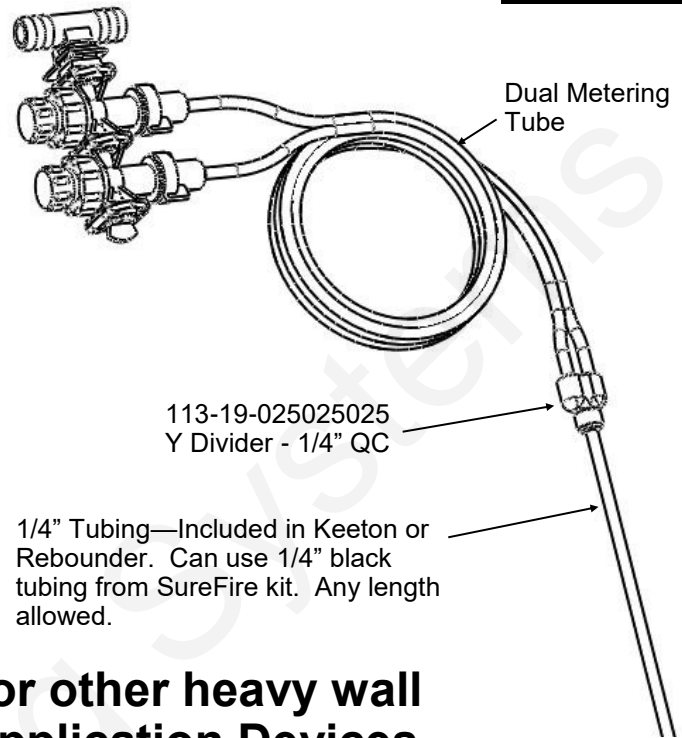

Connection to Totally Tubular or other heavy wall Stainless Steel Tube Ground Application Devices

When using a 3/8" OD stainless steel tube to apply fertilizer to the ground, there are two options for the delivery tube plumbing. If the tube ID is less than 1/4" (tubing will not fit inside tube) this attachment method must be used. The description following is for Option 1. See bottom right picture for Option 2.

1. Use the 1/4" x 3/8" QC fitting shown. Push the 3/8" end onto the stainless steel tube. (Hint: if the fitting slips off the stainless steel tube, use sandpaper or a file to roughen the end of the tube slightly)
2. Use a short piece of 1/4" black tubing to connect the Y fitting to the reducer fitting on the stainless steel tube.
3. Zip all tubing to the planter and row unit in as many locations as possible.

Option 1: QC Fitting attaches to SS Tube

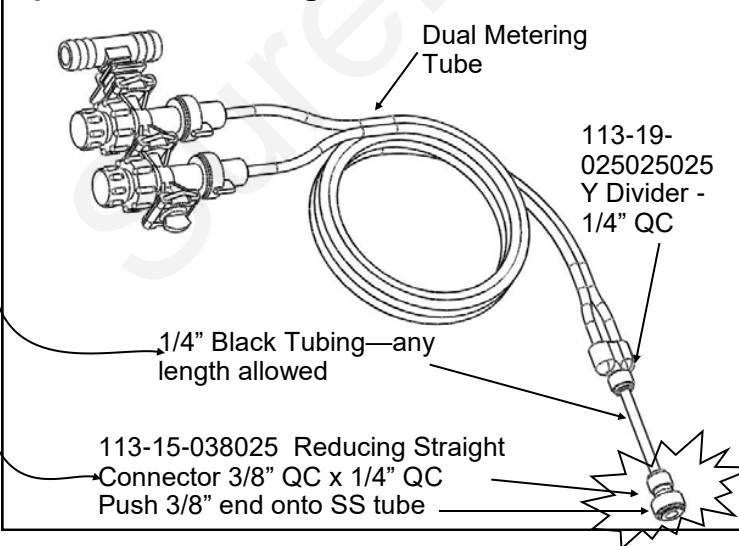

Option 2: 3/8" Hose attaches to SS Tube

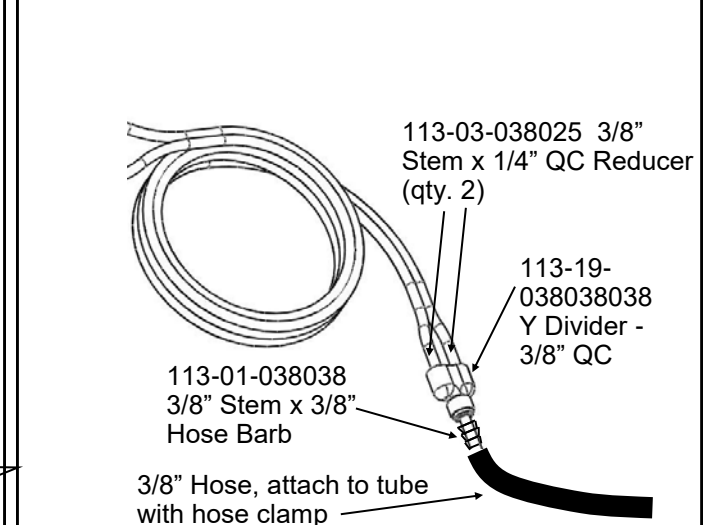

John Deere Rate Controller 2000 (JDRC 2000)



SureFire Fertilizer Systems begin at the JDRC 2000, which you will need to purchase from your John Deere dealer. The picture below shows the JDRC 2000, which can control up to 5 products, depending on features and types of products.

The JDRC 2000 bundle from your John Deere dealer will likely include a harness which connects the rate controller to the John Deere CAN BUS harness. This harness will also have a 47-pin connector on it which connects to the fertilizer system components. SureFire has harnesses that start at this 47-pin connector and connect it to SureFire and other fertilizer systems. The 47-pin connector is limited to applying 2 products with a limit on section number depending on the exact configuration.

If you will be applying 3 products or need additional sections the 47-pin connector will not support this. You need a harness which will plug into the center connector on the JDRC 2000 to support additional products and sections. SureFire has adapter harnesses which replace the harness furnished with the JDRC 2000. These harnesses connect the JDRC 2000 to the John Deere CAN BUS and also provide connections for up to 4 products and 16 sections.

Instructions for setting up the JDRC 2000 are included with the SureFire 47-pin or ECU adapter harness. Detailed screen shots of the display are included showing exactly what settings are required and recommended for SureFire Fertilizer Systems.

1 or 2 Product Harness Layout with John Deere 47-pin

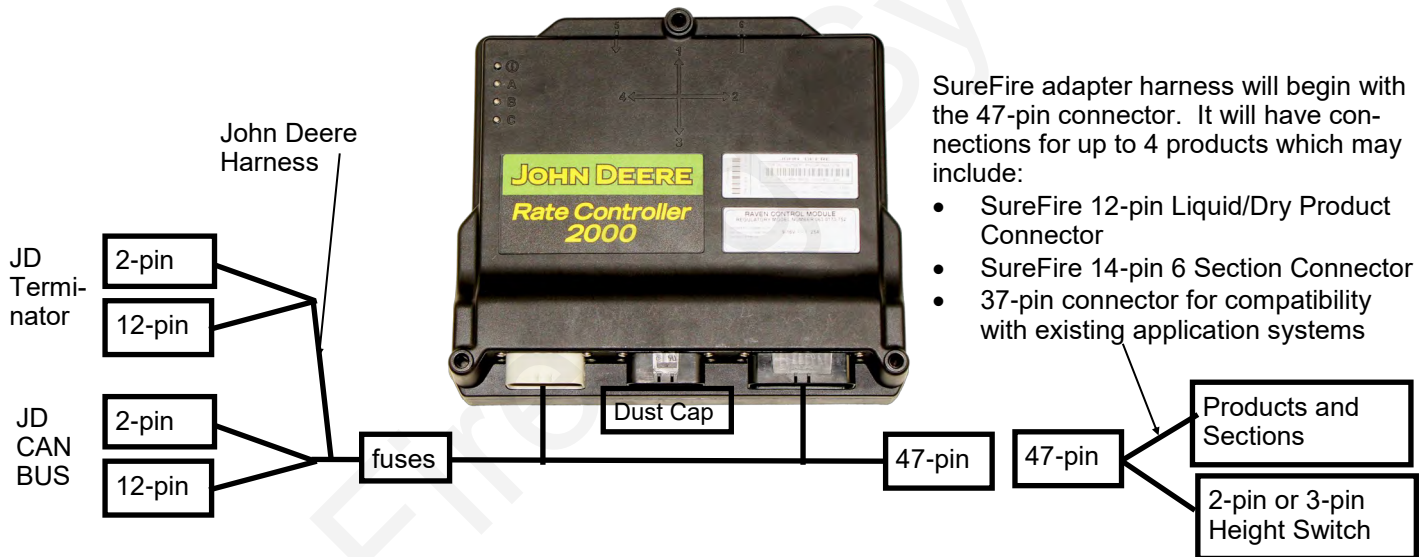

1 to 4 Product Harness Layout with SureFire Direct to JDRC 2000 ECU

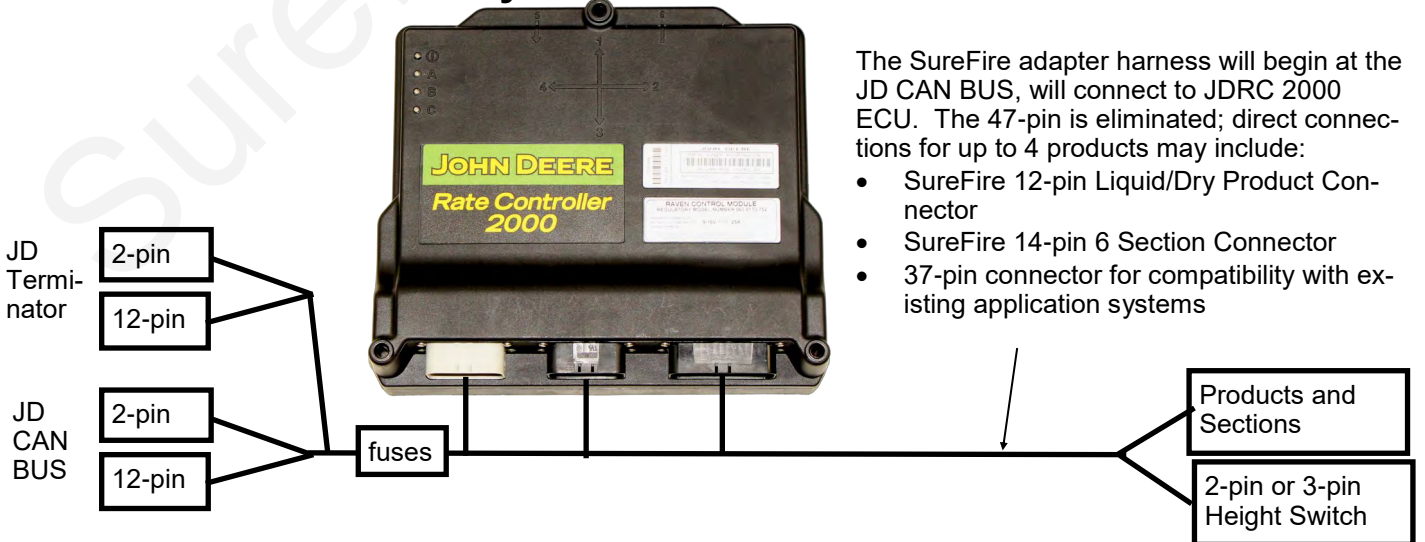

Example PumpRight & JDRC 2000 Layout



The harnessing shown below would be used to connect a SureFire PumpRight system with up to 6 section valves to the JDRC 2000.

Using 47-pin Connector

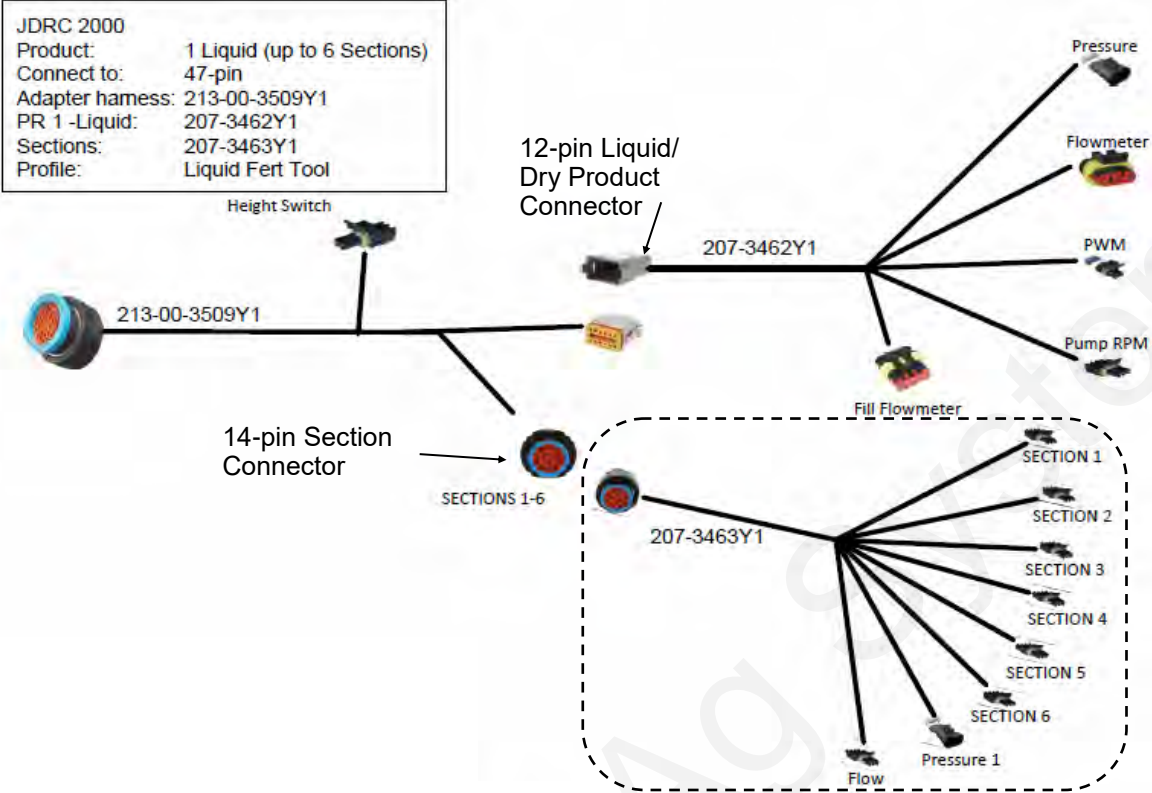

Using SureFire Direct to JDRC 2000 ECU (no 47-pin connector)

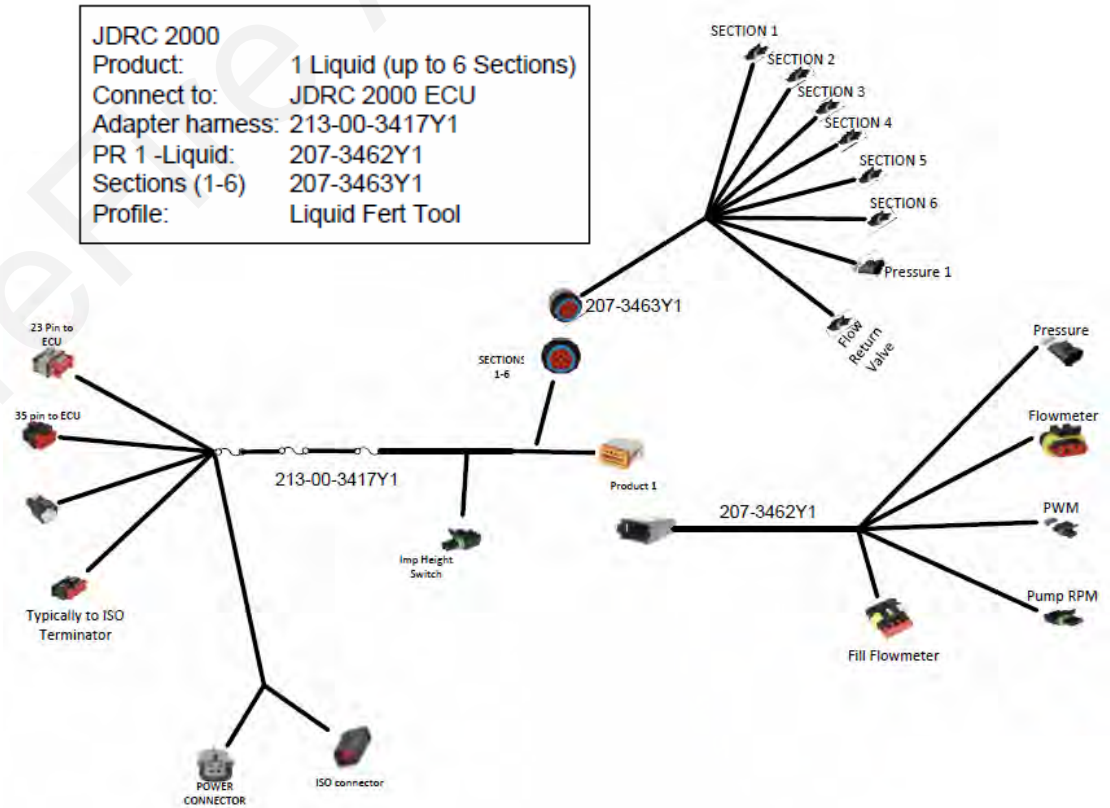

SureFire Ag Systems and JDRC 2000 Harnessing

JDRC 2000
 Product: 1 Liquid (up to 6 Sections)
 Connect to: 47-pin
 Adapter harness: 213-00-3509Y_
 PR 1 -Liquid: 207-3462Y2
 Sections: 207-3463Y1
 Profile: Liquid Fert Tool

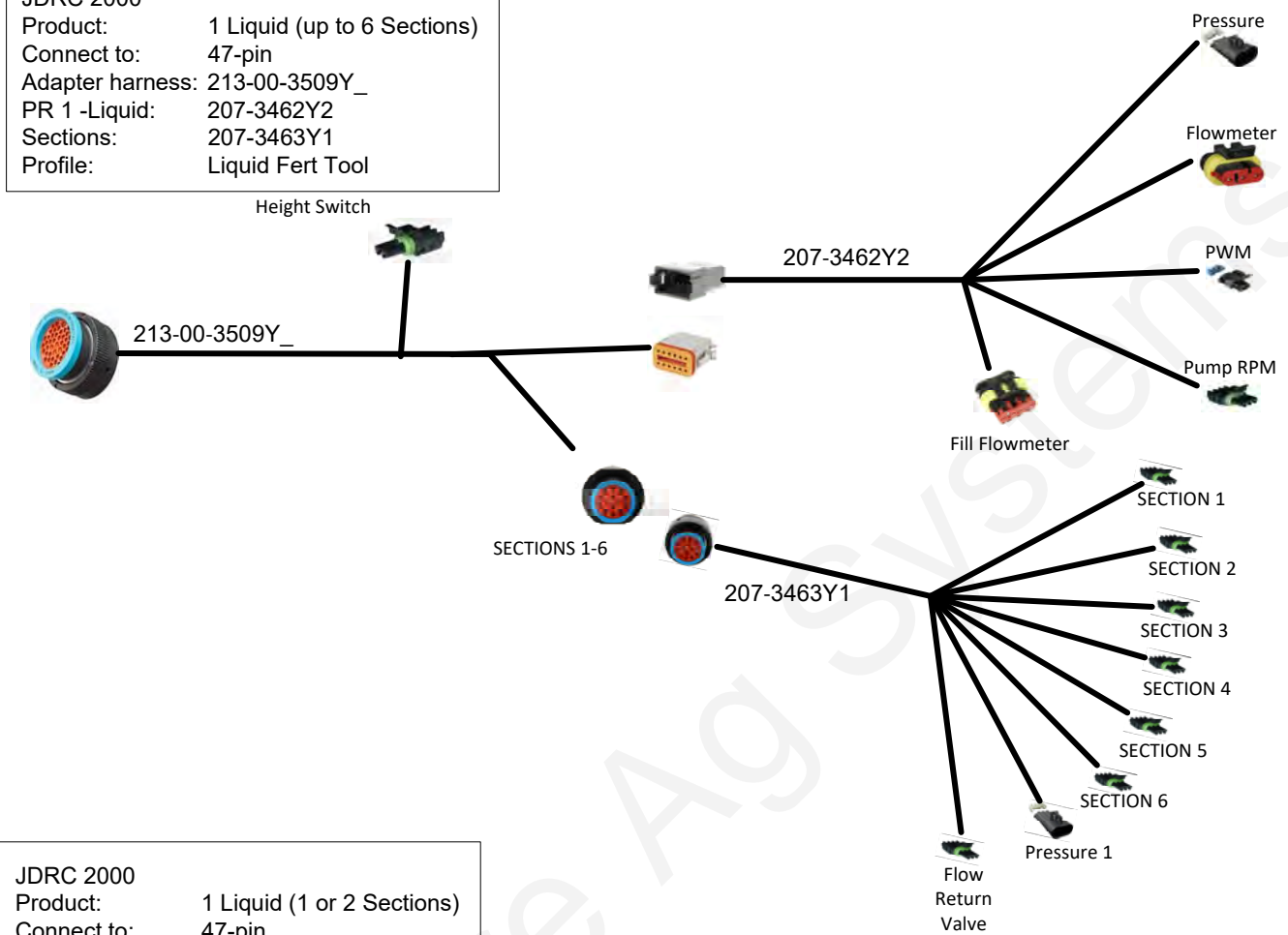

JDRC 2000
 Product: 1 Liquid (1 or 2 Sections)
 Connect to: 47-pin
 Adapter harness: 213-00-3509Y_
 PR 1 -Liquid: 207-3461Y2
 Profile: Liquid Fert Tool

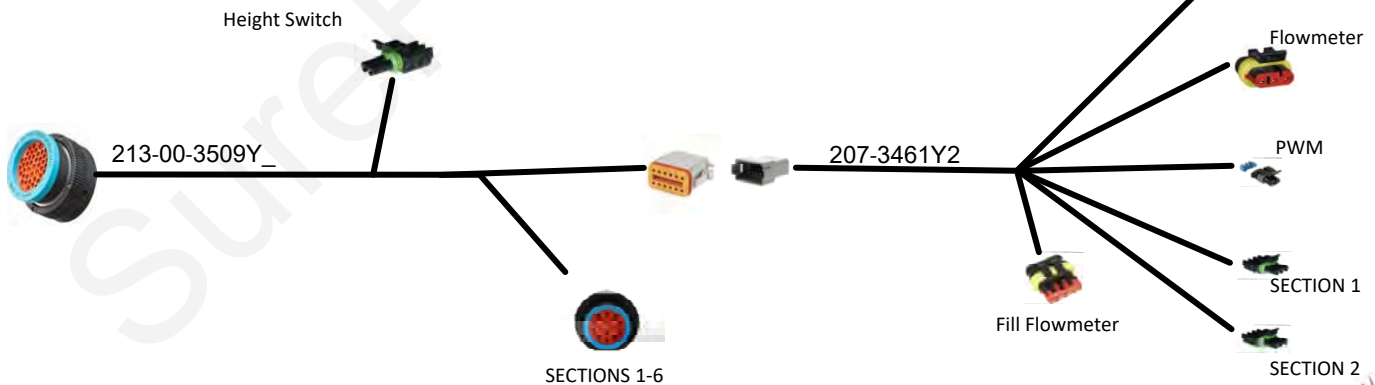

©2017 SureFire Ag Systems, Inc.—All Rights Reserved

SureFire Ag Systems and JDRC 2000 Harnessing

JDRC 2000
 Product: 1 Liquid (up to 6 Sections)
 Connect to: JDRC 2000 ECU
 Adapter harness: 213-00-3417Y_
 PR 1 -Liquid: 207-3462Y2
 Sections (1-6) 207-3463Y1
 Profile: Liquid Fert Tool

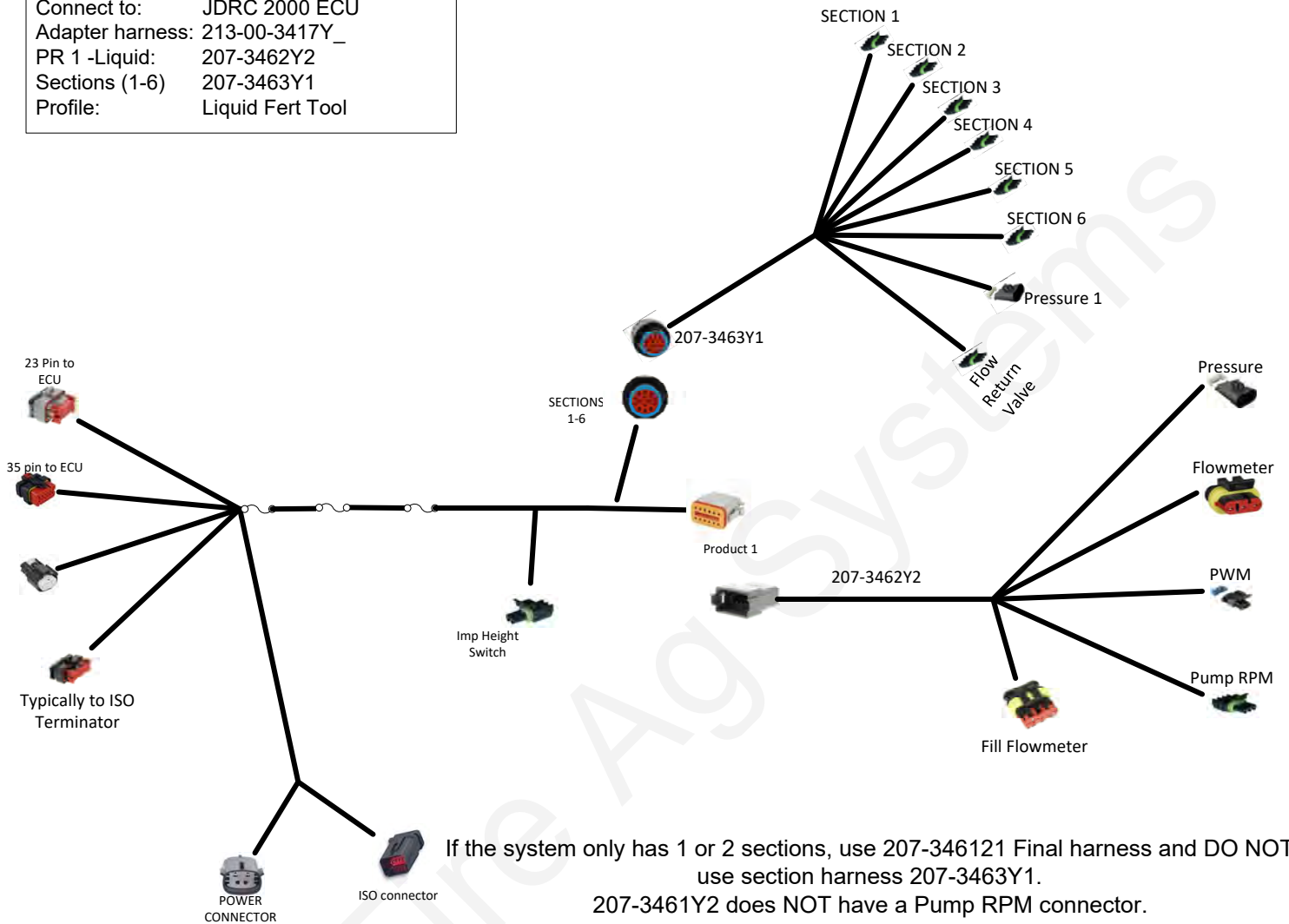

JDRC 2000
 Product: 1 Liquid or 1 NH3
 Connect to: 47-pin
 Adapter harness: 213-00-3370Y_
 PR 1 -Liquid: Existing 37-pin harness
 Sections
 Profile: Liquid Fert Tool (or NH3)

213-00-3370Y_
 47-pin to 37-pin for
 Liquid or NH3

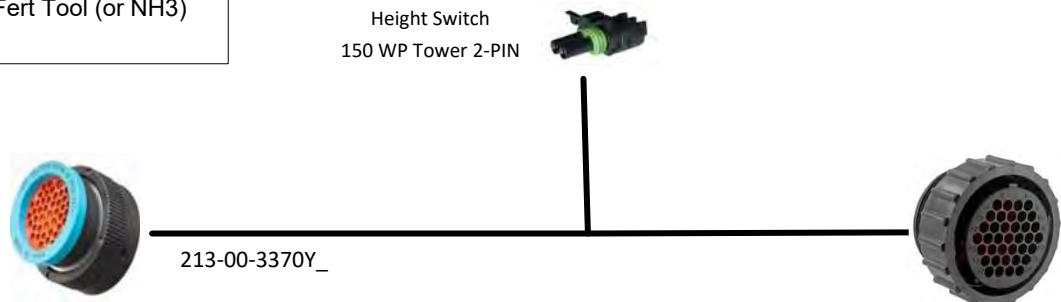

©2017 SureFire Ag Systems, Inc.—All Rights Reserved

SureFire Ag Systems and JDRC 2000 Harnessing

JDRC 2000
 Product: 2 Liquids
 Connect to: 47-pin
 Adapter harness: 213-00-3453Y_
 PR 1 -Liquid: 207-3462Y2
 Sections (1-6) 207-3463Y1
 PR 2 Liquid (Sect 7-8): 207-3461Y2
 Profile: Generic

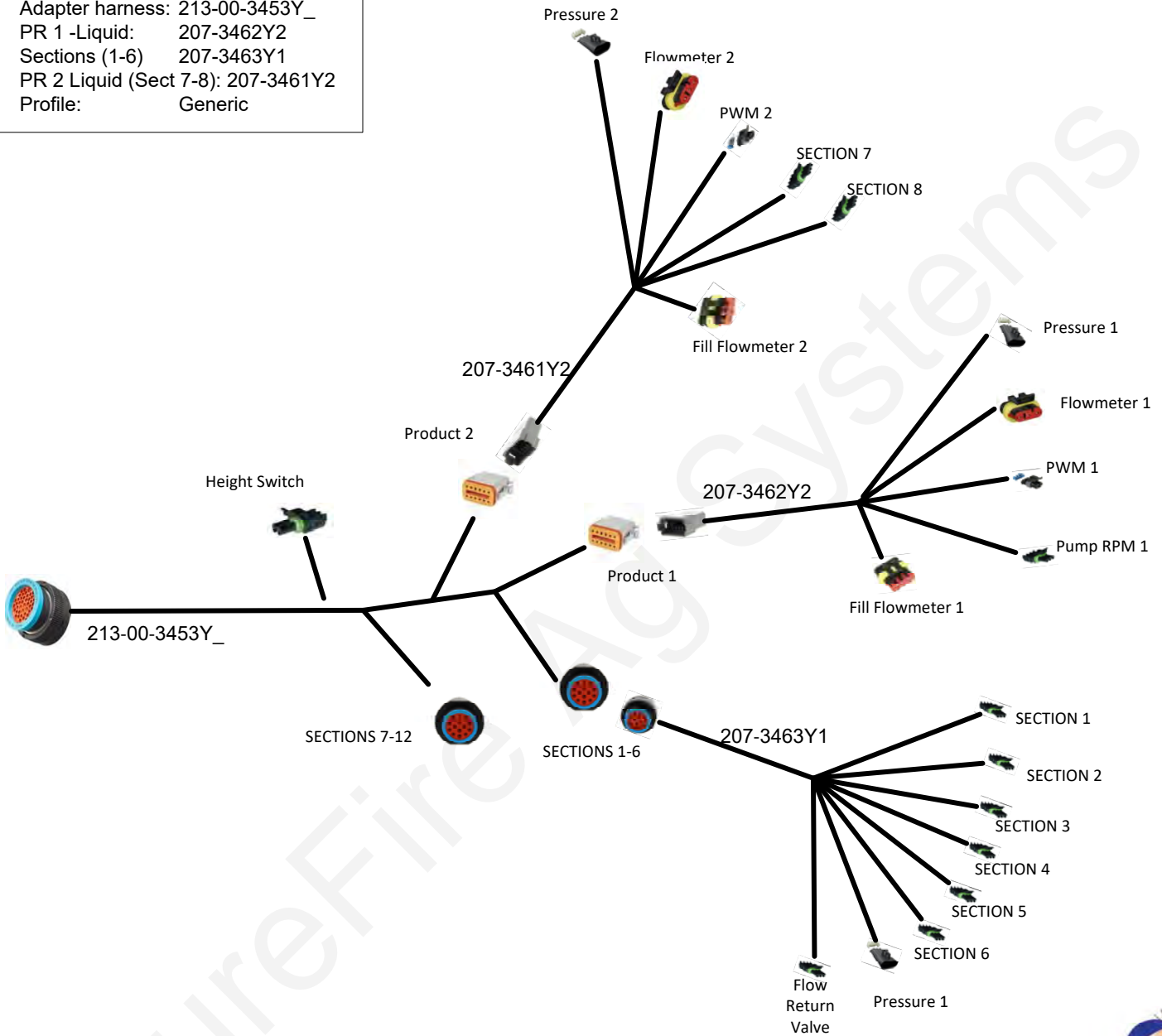

©2017 SureFire Ag Systems, Inc.—All Rights Reserved



207-3462Y2

Final Cable for SureFire Liquid Pump System (pwm, flow, pres., pump rpm, fill flow)

**Wire 18AWG
unless otherwise
specified**

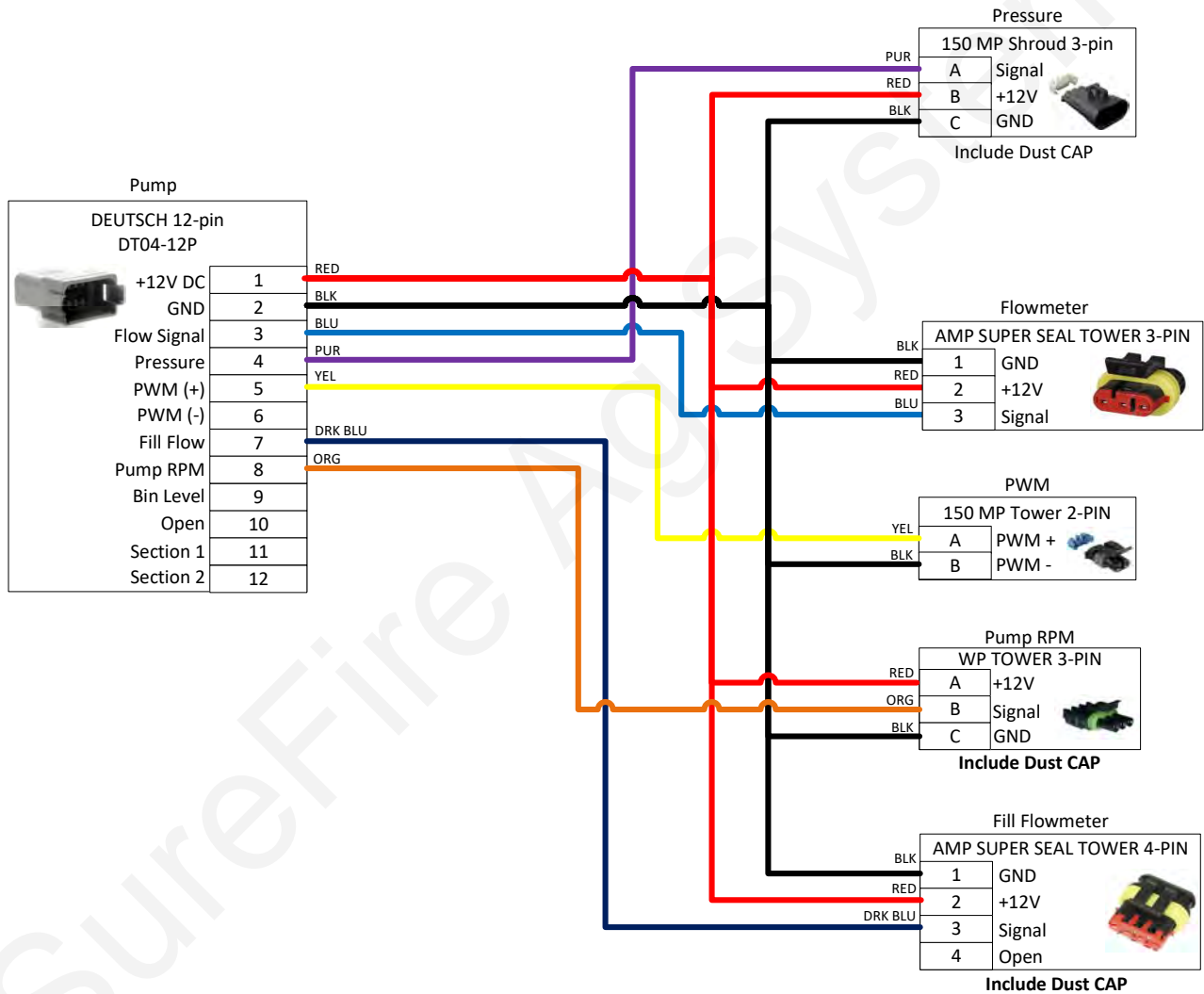

	Part No:	207-3462Y2	Drawn By:	Brandon Cavenee		
	Description:	Final Cable for SureFire Liquid Pump System (pwm, flow, pres., pump rpm, fill flow)	Last Edit Date:	9/4/2018	Revision	A-02
	Copyright 2018 SureFire Ag Systems, Reproduction or other use of drawing without express written permission from SureFire Ag Systems is forbidden			26		

207-3463Y1

14-Pin 6 Section Final Cable (6 sections, flow return, pressure)

**Wire 18AWG
unless otherwise
specified**

Provide dust caps for WP and MP connectors

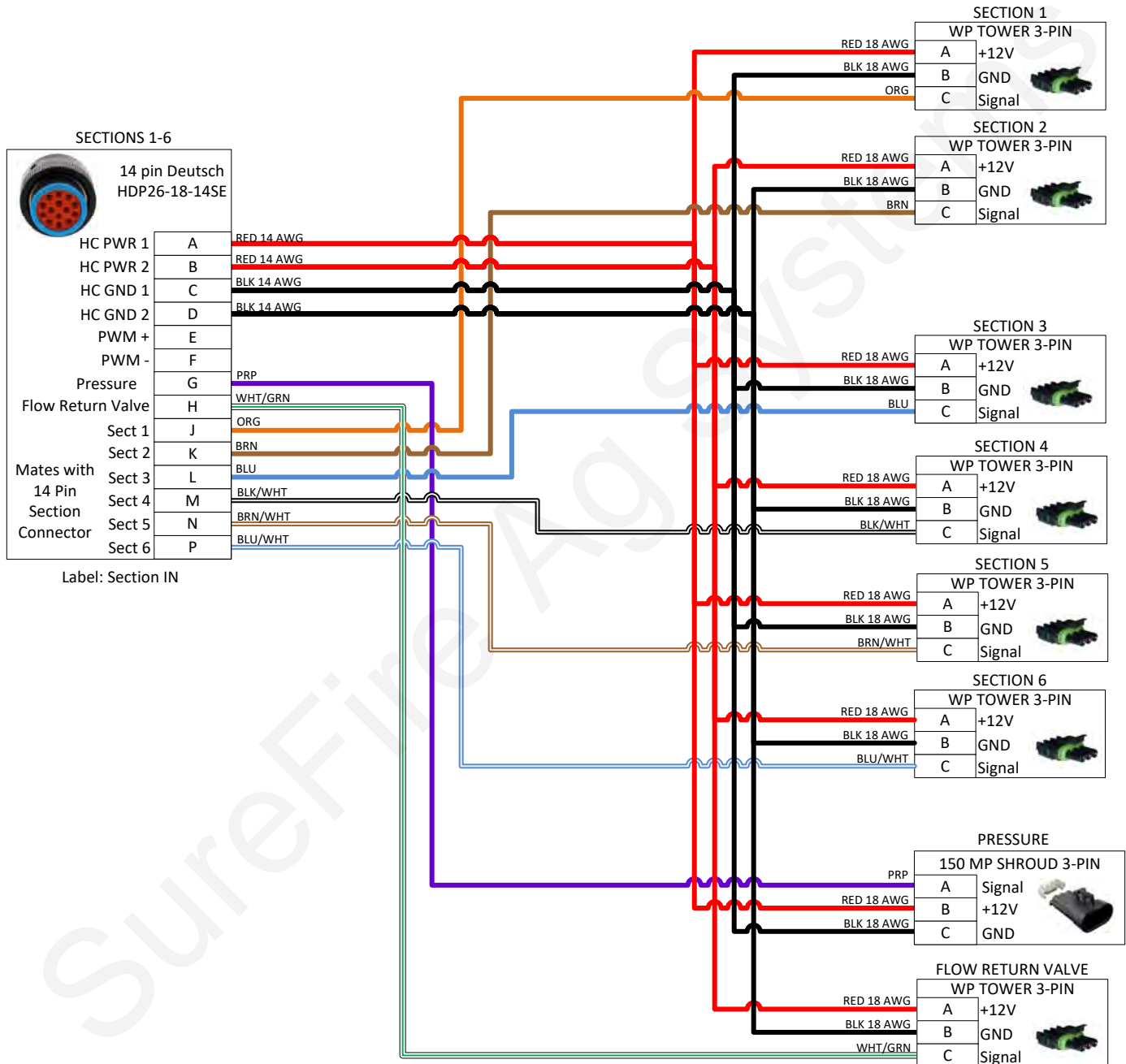

	Part No:	207-3463Y1	Drawn By:	Brandon Cavenee		
	Description:	14-Pin 6 Section Final Cable (6 sections, flow return, pressure)	Last Edit Date:	11/2/2016	Revision	A-01
	Copyright 2016 SureFire Ag Systems, Reproduction or other use of drawing without express written permission from SureFire Ag Systems is forbidden			27		

Floating Ball Flow Indicators

E Installation Overview

Flow Indicators are extremely flexible and can be mounted in hundreds of different configurations on various types of liquid application equipment. This page is to give you some ideas and let you customize the installation for what works best on your equipment.

16 Row Split 6 - 4 - 6

This configuration works well on a 16 row front fold planter. Each flow indicator manifold is shown fed by a cross in a single section installation. Each manifold could be fed by a section valve if desired.

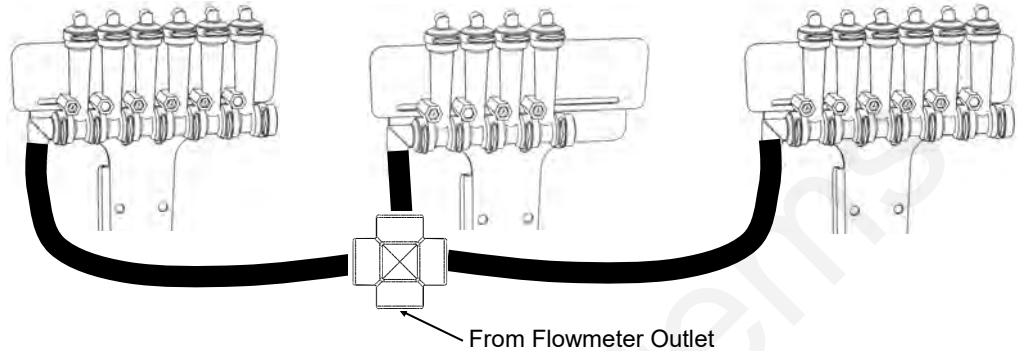

12 Row Split 3 - 3 - 3 - 3

Shown here is a 12 row with four 3 row sections controlled by four section valves. Note each 6 row T-Bracket can hold two separate 3 row manifolds.

A 4 section 24 row could be similar with four 6 row manifolds on two large T-Brackets.

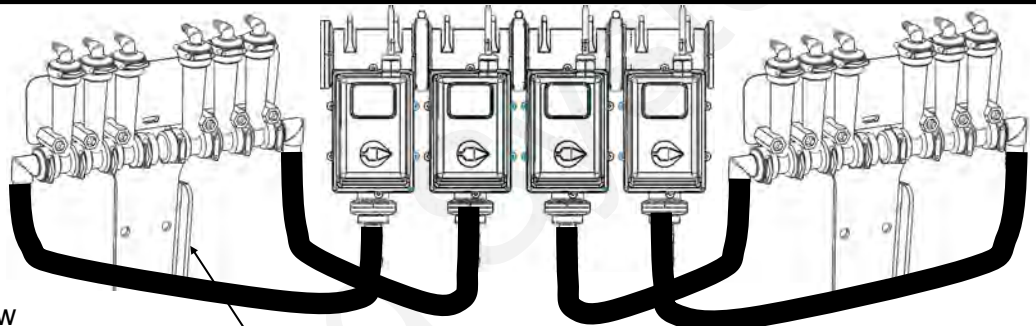

NOTE: Another option is the flange can face forward so the T-Bracket could be mounted on the front side of a bar.

12 Row Dual Product Product 1 Split 4 - 4 - 4 / Product 2 Split 4 - 4 - 4

In this case each manifold would be fed by a section valve. There would be 6 total section valves (3 sections X 2 products). Most often one set (top) of flow indicators would be Full Flow for high rate fertilizer and 2nd set (bottom) would be Low Flow for starter.

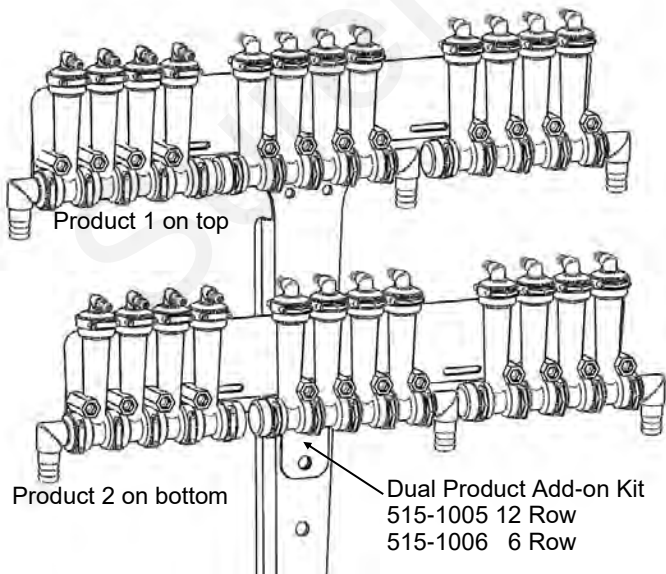

General Plumbing Guidelines

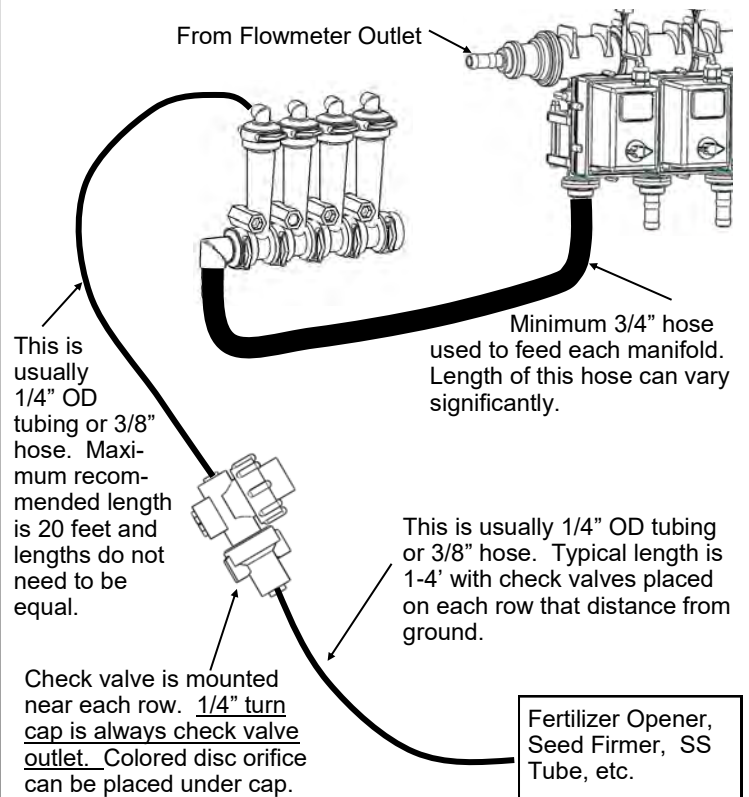

PumpRight Pump Installation

E

Installation
Overview

Mounting

1. Mount pump in your preferred location. The PumpRight pump has excellent suction and priming ability, so it can be mounted away from or above fertilizer tanks.
2. SureFire has U-Bolts available to mount the pump directly to multiple bar sizes shown below. Each U-bolt kit includes 1 bolt and 2 flange nuts.
3. If the U-Bolts will not work, order the universal backer plate kit, number 515-203000 which will clamp to any size tube from 4" - 8" wide.

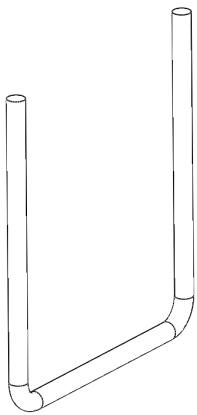

Mounting Bar
Size

Mounting Bar Size	Item Number	Item Description
3" x 3"	380-1022	1/2" U-bolt Kit - 1/2", fits 3" x 3" tube - (3" opening)
4" x 4"	380-1023	1/2" U-bolt Kit - 1/2", fits 4" x 4" tube - (4" opening)
4" x 6"	380-1015	1/2" U-bolt Kit - 1/2", fits 4" x 6" tube - (4" opening)
	380-1017	1/2" U-bolt Kit - 1/2", fits 6" x 4" tube - (6" opening)
5" x 7"	380-1014	1/2" U-bolt Kit - 1/2", fits 5" x 7" tube - (5" opening)
	380-1016	1/2" U-bolt Kit - 1/2", fits 7" x 5" tube - (7" opening)
6" x 7"	380-1018	1/2" U-bolt Kit - 1/2", fits 7" x 6" tube - (7" opening)
7" x 7"	380-1001	1/2" U-bolt Kit - 1/2", fits 7" x 7" tube - (7" opening)
6" x 10"	380-1021	1/2" U-bolt Kit - 1/2", fits 6" x 10" tube - (6" opening)
8" x 12"	380-1019	1/2" U-bolt Kit - 1/2", fits 8" x 12" tube - (8" opening)
8" x 16"	380-1020	1/2" U-bolt Kit - 1/2", fits 8" x 16" tube - (8" opening)



PumpRight Hydraulic Connections PWM Valve

E

Installation Overview

Manual Override - Push down and turn 1/2 turn CCW to lift the valve for manual override to check for proper hydraulic operation. **Override will completely open valve, so limit tractor hydraulic flow to valve.** (May need to clean packed dirt to allow movement of override knob.) Push down and turn 1/2 turn CW to return to operating position.

Load Sense Port—For power beyond hydraulic use only.

Bypass Valve—Remove the cap to access a bypass needle valve. This valve is shipped from the factory closed. **The only case when valve should be open is when running in series with other hydraulic motors.**

Depending on your tractor and exact hydraulic plumbing scenario your pump may turn very slowly when it should stop. To stop the pump completely, open the bypass valve slightly.

To adjust the Bypass Needle Valve, first loosen the lock nut. Do not overtighten the needle valve.

Return oil to Tank - Check valve included on return port

PWM Valve Connector -2 Pin MP Shroud
Troubleshooting Tip:
To check coil, an ohmmeter placed on the two pins should show 7-9 ohms.

Pressure line from Tractor

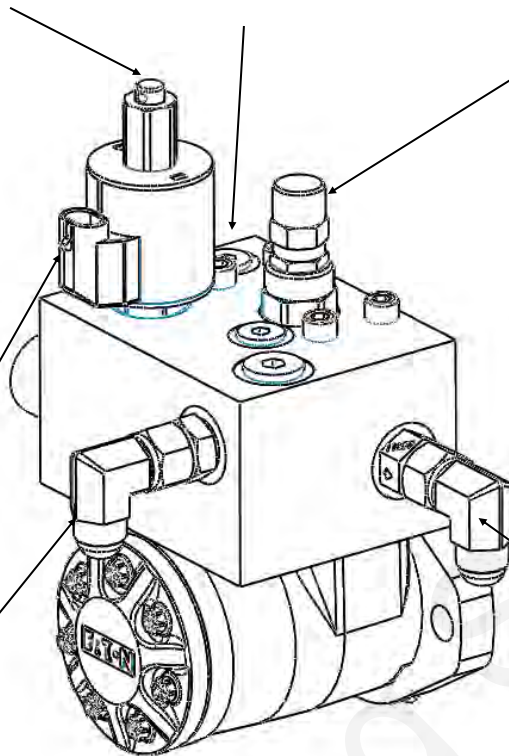

▲ DANGER

Hydraulic oil under extremely high pressure. Do not use hand or any other skin to check for or to stop hydraulic leaks. Be sure pressure is relieved before loosening hydraulic fittings. Replace worn hoses immediately. Seek medical care immediately if hydraulic oil is shot into the eye or the skin.

Pump Rotation Check Valve

A check valve is included on the outlet port of the hydraulic valve. This prevents the pump from running in the wrong direction. If ran in the wrong direction, liquid will be pumped, however the hydraulic valve will not be able to control the flow. The check valve can be identified by the Part Number 1108R stamped on it and a flow direction arrow.

How it Works with Power Beyond Hydraulics

This valve is designed to work with power beyond hydraulics. This configuration will not require a standard tractor remote hydraulic valve. The load sense port and hose described next will typically not be needed if other hydraulic ports are in use. If the load sense is needed, do this: First, remove the load sense plug and install a #6 male boss x #6 JIC adapter fitting, SureFire PN 161-01-6MB-6MJ. Then run a 3/8" or 1/4" hydraulic hose back to the tractor. This hose will connect to the load sense port on the tractor. The load sense line will signal the tractor hydraulic system to supply the flow needed by the pump to meet your application rate. The SureFire valve has an internal load sense check valve, which is required for power beyond hydraulics.. The bypass valve (see above) must be closed to use power beyond hydraulics or else an unlimited amount of oil will be continuously circulated.

PumpRight Hydraulic Connections

E

Installation
Overview

Hydraulic Hose

SureFire recommends 1/2" hydraulic hose for both pump inlet and outlet. The hoses will need #8 JIC female swivel fittings.

Where do I get hydraulic flow for my PumpRight?

This question is often asked as many implements use up all the hydraulic connections on a tractor. SureFire has some recommendations as to what works best.

Best Option - Dedicated PumpRight Circuit

If you have a tractor remote available, attach the tractor remote valve directly to the PumpRight pressure and return ports. DO NOT try to avoid this method simply to save another set of hydraulic hoses running to the tractor. Operating the PumpRight on it's own circuit is the simplest for installation and operation. It guarantees the PumpRight won't negatively affect any other hydraulic components on your equipment.

Preferred



SCAN for
video on plumbing
behind CCS fan

Alternate Option - In Series with John Deere CCS Fan or Bulk Fill Seed Fan

If you do not have a tractor remote valve available, this may be your best method. You can plumb the PumpRight after the seed distribution fan in series. If using this method, the SureFire PWM bypass valve must be open (see previous page for instruction & picture). If bypass is left closed, the SureFire valve will limit the speed of the seed distribution fan.

For example, the John Deere CCS fan uses around 7 GPM of oil. This will limit the PumpRight maximum flow (9 GPM oil necessary for maximum flow). See the charts on the next page for adjusted maximum pump flow. See section G for flow charts to determine your necessary flow rate.

DO NOT plumb the PumpRight in series with a vacuum fan. The vacuum fan uses just a few GPM of oil. Also, problems will be caused by excessive pressure at the vacuum fan motor

Two PumpRights

The preferred method is to plumb the two pumps in series. DO NOT plumb two pumps after the CCS fan. Excessive pressures may damage the CCS fan motor. Run the pressure line from tractor to first pump inlet. Plumb from the outlet of Pump 1 to the Inlet of Pump 2, then from Pump 2 outlet back to the tractor. Open the bypass needle valve on both pumps so each valve controls motor speed independently. Run the flow setting procedure on the next page to minimize the hydraulic flow based on the pump that requires more hydraulic motor flow.



▲ DANGER

Hydraulic oil under extremely high pressure. Do not use hand or any other skin to check for or to stop hydraulic leaks. Be sure pressure is relieved before loosening hydraulic fittings. Replace worn hoses immediately. Seek medical care immediately if hydraulic oil is shot into the eye or the skin.

PumpRight Hydraulic Oil Flow Requirements

(Requirements for 4.0 CID Motor—standard SureFire motor beginning in 2016—
Earlier motor was 4.9 CID which uses 20% more oil)

E

Installation
Overview

Setting Tractor Hydraulic Remote Speed

PumpRight pumps require a constant hydraulic oil flow from the tractor. The amount of oil needed varies with pump size and speed. The chart at right shows the necessary oil flow for each pump model at varying fertilizer flows.

Use this procedure to determine the correct setting on your tractor hydraulic flow.

1. Run the fertilizer system in the field at the maximum rate and ground speed.
2. Turn down the hydraulic flow slowly while watching the pump flow (Volume / Minute).
3. Observe when the Volume / Minute begins to drop.
4. Turn the hydraulic flow back up slightly.

This setting will provide the Pump Right pump just enough oil for your application rate.

If running with the bypass open (only recommended when 2 motors are operated in series) this process will minimize the oil circulated in the bypass loop, leaving more oil flow for other hydraulic functions.



The pump is rated at a maximum of 550 RPM. Spinning the pump over 550 RPM may cause pump failure.

The system will spin the pump faster than that if precautions are not taken to limit the speed. This could happen if the strainer becomes plugged or blocked and the controller attempts to speed the pump up to achieve the desired Rate. It could also happen if a high pressure situation occurs that opens the Pressure Relief Valve (PRV) and the pump speeds up to try to achieve the Rate.

Monitor the pump RPM. If the pump begins to speed up, check for a blocked strainer or other issue.

Set the Pump RPM High Limit and Maximum Pressure Alarm as shown in Section F.

Another way to limit the maximum pump speed is to set the High PWM Limit just above what is needed for regular operation. If the pump tries to speed up above that, check for blocked strainer or other issue.

Model PR17 - 3 Diaphragms		
Fertilizer Flow (GPM)	Pump Speed (RPM)	Hydraulic Oil Flow (GPM)
5	137	2.4
10	275	4.8
15	412	7.1
17	467	8.1

Model PR30 - 3 Diaphragms		
Fertilizer Flow (GPM)	Pump Speed (RPM)	Hydraulic Oil Flow (GPM)
5	85	1.5
10	170	2.9
15	255	4.4
20	340	5.9
25	425	7.4
30	510	8.8

Model PR40 - 4 Diaphragms		
Fertilizer Flow (GPM)	Pump Speed (RPM)	Hydraulic Oil Flow (GPM)
10	115	2.0
20	229	4.0
30	344	6.0
40	458	7.9

Model D250 - 6 Diaphragms		
Fertilizer Flow (GPM)	Pump Speed (RPM)	Hydraulic Oil Flow (GPM)
10	86	1.6
20	172	3.2
30	258	4.8
40	343	6.4
50	429	8.0
55	472	8.6



PR17 & PR30 Liquid Plumbing Connections

E

Installation
Overview

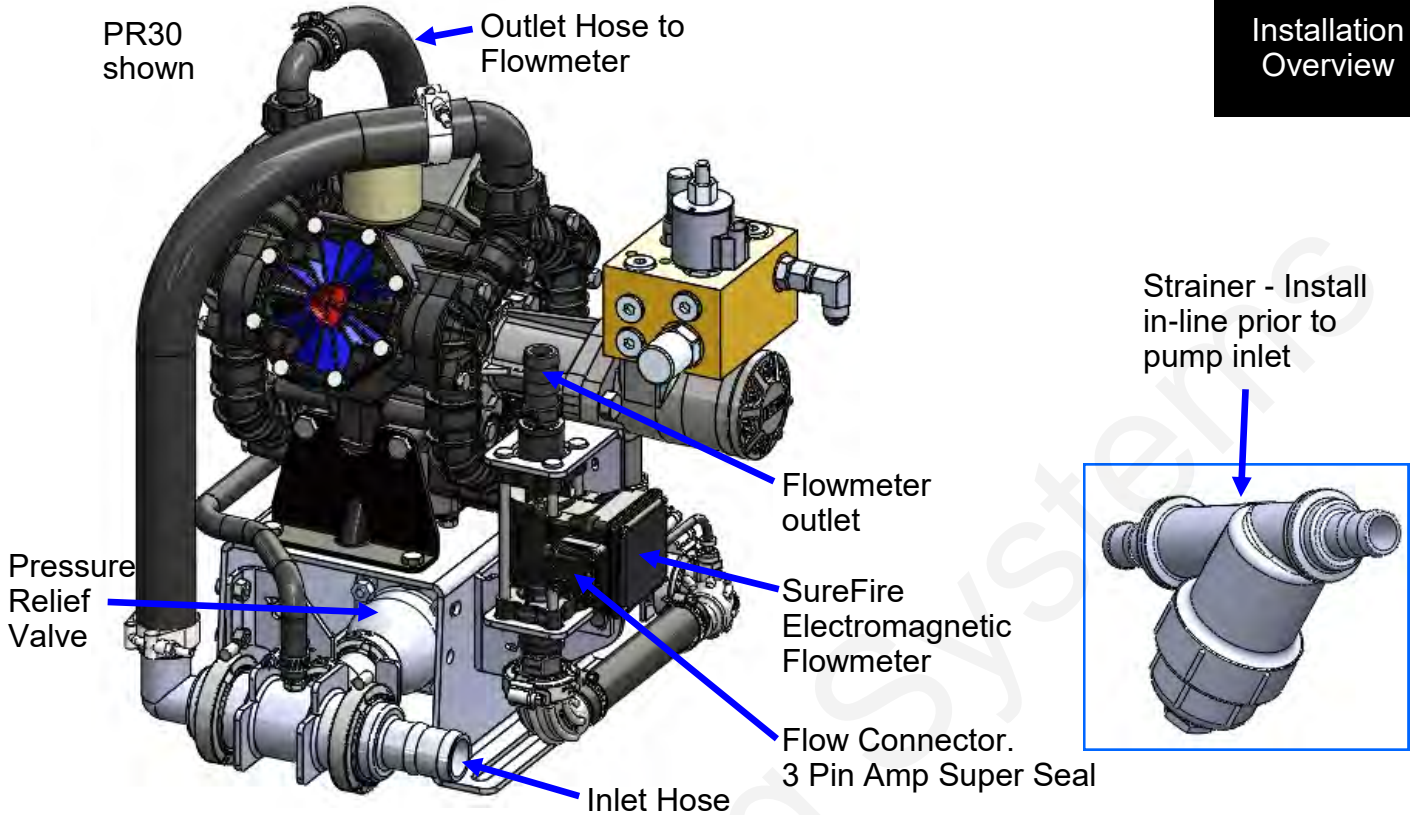

Inlet: The PR17 and PR30 PumpRight are shipped with a 1 1/2" inlet hose barb. Attach this to the hose from your supply tank and strainer. A 1 1/2" 90 degree hose barb is included and can be substituted.

Inlet Strainer: A 20 mesh strainer is included in the pump kit. The manifold strainer includes two hose barbs so it can be mounted anywhere in the inlet line. If space allows, the strainer can be mounted directly to the inlet plumbing assembly as shown below.

Outlet: The outlet is plumbed directly to the flowmeter with 1" hose. As shown above, the flowmeter may be mounted directly to the PumpRight pump. The flowmeter outlet is a 1" hose barb. The outlet hose should be a minimum of 24" long with a gentle curve prior to any fittings for optimum flowmeter performance. The flowmeter outlet will attach to your manifold(s) or section valves. A 3/4" hose barb is included in the bag of parts and can be substituted on the flowmeter outlet.

Pressure Relief Valve (PRV): The PRV is a 100 psi relief. If there is a restriction that creates over 100 psi in the system, the PRV will open allowing the excess flow to pass back to the inlet side of the pump. This protects the pump and fertilizer system from damage.

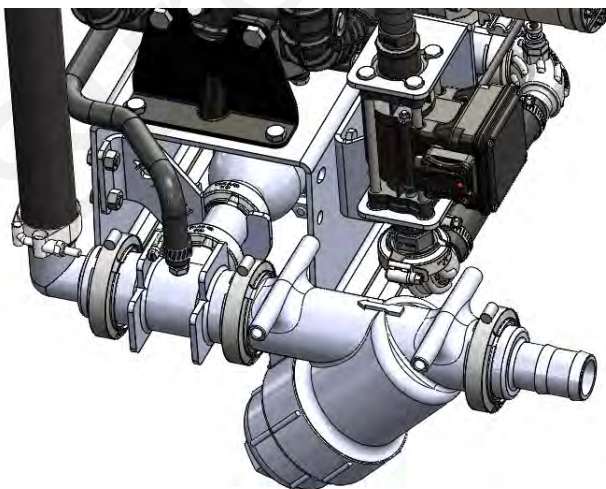





CAUTION

These pumps can deliver liquid at high pressure (290 PSI). Be sure the 100 PSI Pressure Relief Valve (PRV) is installed and functioning so system pressure will be kept under 100 PSI. Check hoses, hose clamps, and liquid fittings regularly and repair or replace loose connections.

PR40 & D250 Liquid Plumbing Connections

E

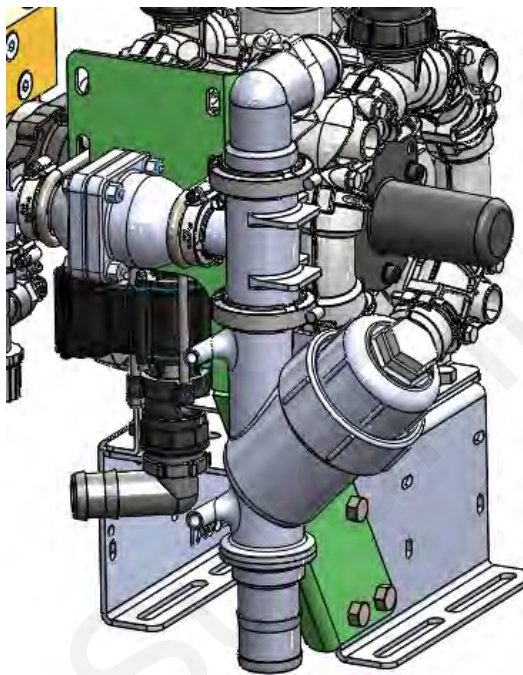
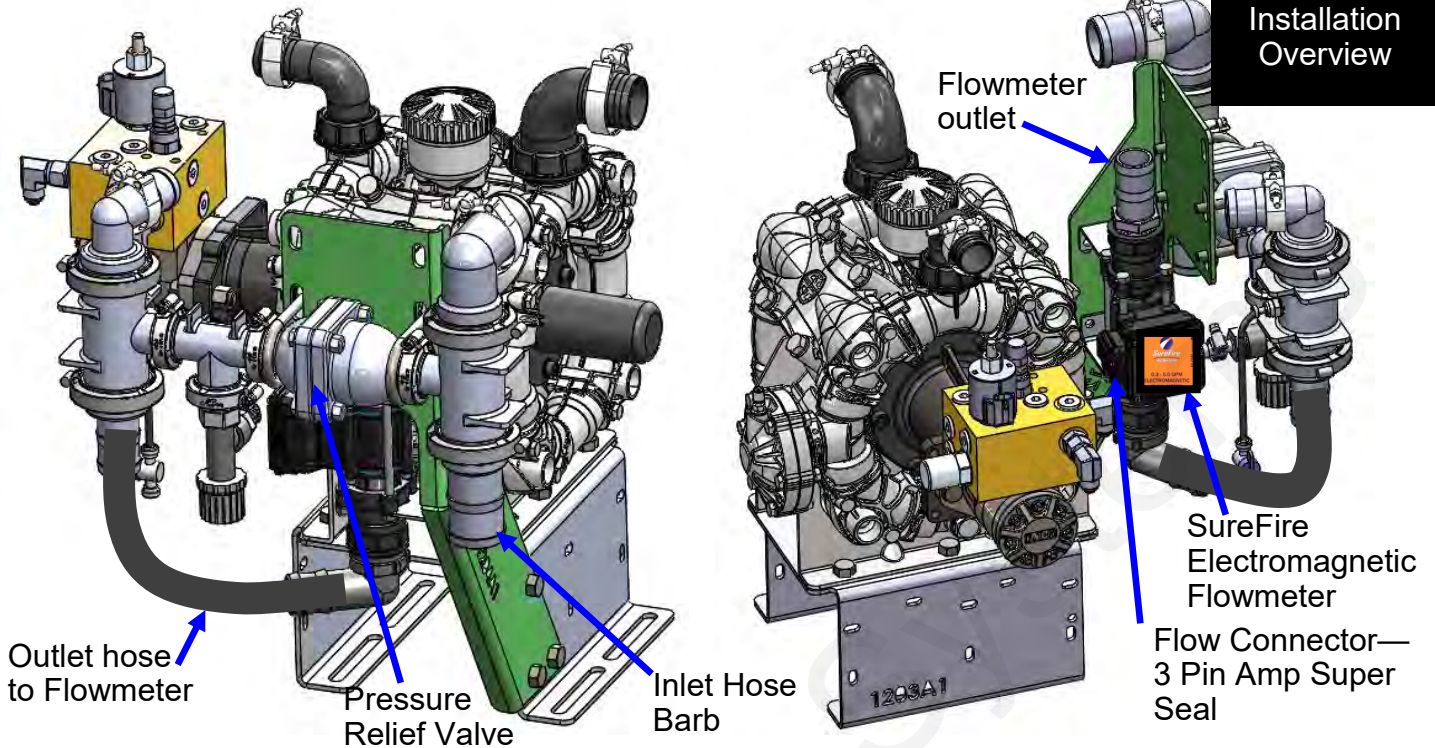
Installation
Overview



Inlet: The PR40 and D250 PumpRight are shipped with a 2" inlet hose barb. Attach this to the hose from your supply tank and strainer. A 2" 90 degree hose barb is included and can be substituted.

Inlet Strainer: A 20 mesh strainer is included in the pump kit. The manifold strainer includes two hose barbs so it can be mounted anywhere in the inlet line. If space allows, the strainer can be mounted directly to the inlet plumbing assembly as shown in image to the left.

Outlet: The outlet is plumbed directly to the flowmeter with 1 1/2" hose. As shown above, the flowmeter may be mounted directly to the PumpRight pump. The flowmeter outlet is a 1 1/2" hose barb. The outlet hose should be a minimum of 24" long with a gentle curve prior to any fittings for optimum flowmeter performance. The flowmeter outlet will attach to your manifold(s) or section valves.

Pressure Relief Valve (PRV): The PRV is a 100 psi relief. If there is a restriction that creates over 100 psi in the system, the PRV will open allowing the excess flow to pass back to the inlet side of the pump. This protects the pump and fertilizer system from damage.



CAUTION

These pumps can deliver liquid at high pressure (290 PSI). Be sure the 100 PSI Pressure Relief Valve (PRV) is installed and functioning so system pressure will be kept under 100 PSI. Check hoses, hose clamps, and liquid fittings regularly and repair or replace loose connections.

Rate Controller Setup



This manual is written for the John Deere Rate Controller 2000 (JDRC 2000). Screenshots here are from the 2630 display. On the Gen 4 (4640) display, operation is the same, but some screenshots may appear differently.

To access the JDRC 2000, push this button. If this button is not present the rate controller is not communicating with the display. See your John Deere operators manual or your John Deere dealer for assistance.

This button will take you to the Main Rate Controller Screen below.

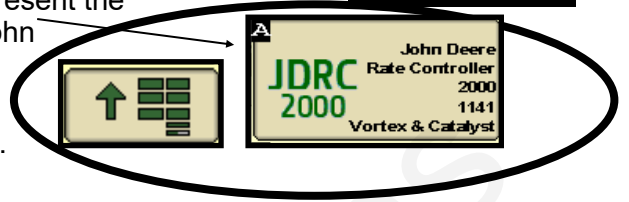

Main Rate Controller Screen

Actual Rate **Target Rate** **Tractor Speed**

Display Settings >
The items that will show here can be selected in *Setup > Settings > Display Settings*

Estimated Volume Remaining / Tank Refill Button (press to refill tank)

Press the box to select which item will display in these two boxes.

Navigation Buttons
JDRC 2000 Screen
Setup
Totals
Diagnostics

Implement Height Switch Indicator, Arrow will point up or down to indicate implement position if height switch is used (not being used in this photo).

Menu Structure

- Implement
- Settings
- Alarms
- Rates

- ### Setup
- **Implement** > Profile > Height Switch > Test Speed
 - **Settings** > Control Valve Setup
Flow/Rate Sensor Setup
Tank/Bin Setup
Display Settings
Pressure Sensor Setup
Auxiliary Features Setup
- ### Alarms
- **Rates** Rates, Rate Smoothing, Decimal shift

- ### Totals
- Current
 - Job Summaries
 - Lifetime Totals
- ### Diagnostics
- Readings
 - Tests
 - System Summary
 - Product Summary

See the John Deere JDRC 2000 Operator's Manual for safety information and additional setup/operating information.



The operator is responsible for knowing and understanding the safe operation of this equipment. Systems with hydraulic equipment require additional safety precautions to prevent serious injury and/or death.

Typical Setup instructions for JDRC 2000 and SureFire harness for 2 Liquid/Dry Products

213-00-3453Y4 213-00-3467Y4 213-00-3538Y4 213-00-3585Y4



Other systems will have similar setup entries. See the setup sheet for your system.

Below are typical SureFire Liquid Fertilizer System setup screens. *Your setup will likely vary.*

See the JDRC 2000 Operator's Manual for safety information and additional setup/operating information.

For a Gen3 LiquiShift system, see the setup guide for that system ([1-product](#) or [2-product](#))

For other systems, see the setup guide for [1-product](#), [2-product](#), or [3-product](#) systems.

1. Navigate to the Profile Setup:

For initial setup, start a new profile. The JDRC 2000 allows you to store 8 profiles. Be prepared to wait during this phase of the setup.

2. Enter a Profile Name. Machine Type—Generic. (Setup for a single product is *Liquid Fert Tool*.) Software Version Number should be 1.12 or higher. 3. Number of Products = 2. (Example)
 4. RPM Sensors—2 (this may vary, Pump RPM sensor)

5. Select Application Type and Application Mode.

6. Set up Section Groups. Section Group 2 will start with Section Driver 7.

Other Section Setups are possible. The standard SureFire harness has Sections 1-6 with Product 1, and Sections 7-12 with Product 2.

If PR 2 is injecting into PR 1, say YES. Are section drivers shared between all products in a product harness? **No** Typical



Typical Setup instructions for JDRC 2000 and SureFire PumpRight:
 Use with SureFire adapter harness: 213-00-3453Y4 or 3467Y4 or 3538Y4 or 3585Y4
 for 2 Liquid/Dry products (Your setup will likely vary from this example)



7. The SureFire pressure sensor will be set up as a **Custom** sensor. Calibration will be done later.

Setup Pressure Sensors

Pressure Sensor 1: Custom

Pressure Sensor 2: Custom

Pressure Sensor 3: None

Pressure Sensor 4: None

Setup Sensor Assignment

Pressure Sensor 1

Product 1:

Product 2:

Assign the Pressure Sensor to the Product it is associated with.

(See Display Settings for instructions on how to show pressure and RPM for a product on the product Run Screen.)

Setup Pressure Alarms

Pressure 1 (psi): Minimum 0, Maximum 85, Alarm?

Pressure 2 (psi): Minimum 0, Maximum 85, Alarm?

On the SureFire wiring harnesses indicated above, Pressure Signal 1 and RPM Sensor 1 are on the Product 1 connector. Pressure Signal 2 and RPM Sensor 2 are on the Product 2 connector. For added protection, set the Maximum Pressure at 85 PSI and check the Alarm box. If necessary, this can be increased.

8. Optional Aux Functions—RPM Sensors

Setup Aux Functions

RPM 1 Calibration Pulses/Rev: 15

RPM 1 Low Limit (rpm): 0

RPM 1 High Limit (rpm): 500

RPM 2 Calibration Pulses/Rev: 15

RPM 2 Low Limit (rpm): 0

RPM 2 High Limit (rpm): 500

Setup RPM Sensor Assignment

RPM Sensor 1

Product 1:

Product 2:

If using a Pump RPM Sensor on Product 1, check the box here.

(The SureFire hydraulic pump with an RPM Sensor is 15 pulses/rev as shown. If monitoring something else, enter the pulses/rev for that encoder or sensor.)

Set the **RPM High Limit** at 500 for a SureFire PumpRight hydraulic pump, and **check the Alarm box**. If maximum pump capacity is needed, this may be increased to 550. (Generally, if the pump tries to go over 500 RPM, there is probably another issue such as a plugged strainer or other problem.)

Also, the **PWM High Limit** (below) can be set at 60 to limit the speed of the pump.

9. Control Valve Setup

Valve Response Rate: (Adjust as needed)

PumpRight (hydraulic) PR17 - 80
 PR30 - 70 PR40 - 60 D250 - 50
 Tower (electric) 100
 Catalyst and Spartan 5-20

If pump is slow responding to rate or speed changes, increase **Valve Response Rate** 10 at a time. If product oscillates around rate going across the field, reduce **Valve Response Rate**.

Low Limit (Adjust in field as needed)

PumpRight (hydraulic) 25
 Tower (electric) 10
 Catalyst and Spartan 5

PWM Startup (Adjust in field as needed)

PumpRight (hydraulic) 40
 Tower (electric) 10-25
 Catalyst and Spartan 5-10

Setup Control Valve

Control Valve Type: PWM Close

Valve Response Rate (1-100): See Above

Control Deadband (%): 2

Setup PWM

Product 1 Liquid

Coil Frequency (Hz): 100

High Limit (%): 100.0

Low Limit (%): See Above

PWM Startup (%): See Above

Tip for Best Startup Performance

For best startup performance, set the **PWM Startup** at or slightly above the normal operating PWM Duty Cycle (DC%). When the pump starts, it will go immediately to that Duty Cycle and then will have just a minor adjustment to lock on to the Target Rate.

Normal Operation PWM Startup

37.1 DC (%) PWM Startup (%) 40.0

If pump starts up too fast, lower the PWM Startup.



10. Rate Sensor (Flowmeter) Setup

Minimum Flow Rate or Flowmeter Low Limit

Typically, these are set at 0. If there is a number here, the controller will not let the pump go below that flow rate. If you will be operating near the low end of the FM range, it may be helpful to have a number here. If entering a number, use the numbers in the table below.

FM Range	Minimum Flow or FM Low Limit
0.3-5.0 gpm	0.2
0.6-13 gpm	0.4
1.3-26 gpm	1.0
2.6-53 gpm	2.0

Flowmeter Calibration and Units

Flowmeter Size (GPM)	Pulses/Gal	Spartan model #	Puls/fl oz
0.08-1.6	22710		
0.13-2.6	3000		
0.3-5.0	3000	115	1700
0.6-13	2000	125	890
1.3-26	2000	135	450
2.6-53	2000	145	220

Check **Tank Fill Monitor** box if using a fill flowmeter (not common). Then enter **Tank Fill Flowmeter Calibration (Units are 10 gal if using the SureFire fill flowmeter.)**

11. Tank and Fill Flowmeter Setup

12. Rates and Rate Smoothing Setup

Set Rates and Rate Smoothing as desired.
Decimal Shift > 0 > Rates above 30.
1 > Rates 1 to 30
2 > Rates < 1.00

13. Off Rate Alarm Setup

Set **Off Rate Alarm** as desired. The **Minimum Flow Rate** box will not be present if a pressure sensor has been assigned to this product. Typically, **Minimum Flow Rate** will be left at 0. See above.

This sheet does not cover every possible setup. Your setup may be different. See the John Deere Rate Controller 2000 Operator's Manual for safety information and complete setup and operating instructions. SureFire harnesses for the JDRC 2000 are designed for specific operating setups. Pinouts on the JDRC 2000 change depending on the Profile Setup and the number of products. See the wiring harness diagram for your harness. More information is available at www.surefireag.com/support or support.surefireag.com

14. All Pressure Sensors must be calibrated. See the boxes below for the procedure. Enter **50.0 mv/PSI** for SureFire 0 -100 PSI, 0 to 5 volt sensor. *(Be sure there is no pressure against the sensor when calibrating. Unplug the sensor during the calibration process. More on Pressure Sensor Diagnostics below.)*

For complete information on how the sensor is operating, go to **Diagnostics > Readings > Pressure Sensors.** *0 Pressure Voltage should be 0.00 V.*



15. Set these 4 items in **Setup > Settings > Display Settings**

- 1) Gal/min
- 2) Pressure (PSI)
- 3) DC(%) (PWM)
- 4) Mi/hr

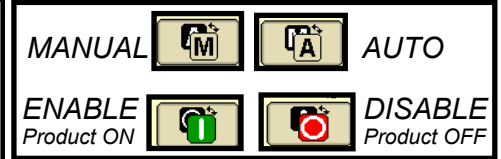
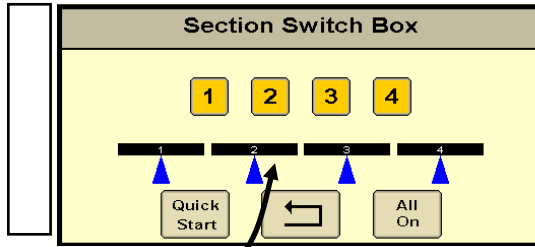

PID Valve Tuning

P	90	D	10
I	10	S	90

Start with these settings for SureFire electric pumps.

16. Advanced Tuning

Do not use Advanced Tuning on SureFire hydraulic pump systems.

On SureFire electric pump systems (Tower 110 and Tower 200), it will be necessary to use the **Advanced Tuning** feature in addition to the regular Control Valve Calibration. To activate **Advanced Tuning**, press and hold the **Settings** tab for about 8 seconds.

On electric pump systems, set the PID Valve Tuning parameters as shown (below left). Press the "?" for an explanation of what each of these values does.

Fine-tuning of the system may require some adjustment of these numbers along with the Valve Response Rate on the Control Valve Setup.

For quickest response on Tower 110 systems set P = 100 and S = 100.

Do not use Advanced Tuning on SureFire hydraulic pump systems.

- TIPS: (1) When first starting the system or when troubleshooting a problem, you can turn OFF either Product 1 or Product 2 and just run the system you want. You can also operate in the field with only one system turned on.
- (2) Go to *Diagnostics > System Summary* for a quick look at the System Settings.
 - (3) Go to *Diagnostics > Product Summary* for a quick look at the settings for each product setup.
 - (4) Go to *Diagnostics > Readings* for important information and feedback: *Hardware/Software, Delivery System, Section Status, System Voltage, Pressure Sensors, RPM Sensors and more.*



Tests for Initial Operation

17. Initial Operation in MANUAL mode:

1. Fill the system with water. For first time startup, open air bleed valve.
2. Enter a Test Speed at Setup > Implement
3. Navigate to MANUAL MODE as shown above for the product you are testing.
4. Height switch must be DOWN (or uncheck Height Switch box).
5. Turn on Master Switch. Press + to increase flow.
6. Monitor Flow (gal/min), PSI, DC, Pump RPM.
7. Go to Section Switch box (above). Turn Sections OFF and ON.
8. Turn Master Switch OFF.



F

Setup &
Operation

NOTICE

Running these tests will dispense liquid. Be sure it is safe to dispense the liquid in your tank in this location.

OPTIONAL MANUAL PUMP OPERATION:

Go to [Diagnostics > Tests > Calibrate PWM LIMITS](#). This is a place where you can manually run the pump without the system shutting down if it doesn't read flow immediately. When you press START, the section valves will open. Press + to increase the PWM Duty Cycle. For electric pumps the DC will have to be 10%-15% to get flow. Hydraulic pumps will need to be around 30% to get flow. When priming the pump, it will help to open the air bleed valve and run the pump faster to get it primed and to get the air out.

TROUBLESHOOTING TIP: Pump Won't Run—Start the Calibrate PWM Limits Test. Run the PWM Duty Cycle (DC) to 100%. With a voltmeter check voltage at the 2-pin PWM connector on the hydraulic valve block for the pump. Should have 12-13 volts. If there is voltage here, but pump won't run, check the pump or hydraulics.

Electric Pump—Unplug the two big connectors at the black EPD module. Plug these together. This will take power from the battery directly to the pump(s). The pump(s) should run full speed.

Hydraulic Pump—On the hydraulic valve block, pop up the Manual Override button (red knob on top of solenoid). If unit has been in the field, you may need to loosen the dirt to move the knob. In cab, turn hydraulic flow to very low. Engage hydraulics. Pump should begin turning. Slowly increase hydraulic flow to speed up pump. Lock red manual override button in DOWN position when finished with the test.

18. Initial Operation in AUTO mode: (Could also do [Diagnostics > Nozzle Flow Check](#)).

1. Enter a Test Speed at Setup > Implement
2. Navigate to AUTO MODE as shown above. Select a Rate.
3. Height switch must be DOWN (or uncheck Height Switch box).
4. Turn on Master Switch.
5. Monitor Actual Rate (gal/ac), Flow (gal/min), PSI, DC, Pump RPM.
6. Go to Section Switch box (above). Turn Sections OFF and ON.
7. Turn Master Switch OFF. (NOTE: Pressure will be much less with water than with heavier, thicker fertilizer.)

Check out the other tests available at [Diagnostics > Tests](#).



WARNING

The operator is responsible for knowing and understanding the safe operation of this equipment. Systems with hydraulic equipment require additional safety precautions to prevent serious injury and/or death. See the full SureFire Manual and the *John Deere Rate Controller 2000 Operator's Manual* for important safety information and setup and operating instructions. Also see www.surefireag.com/support for the SureFire manual.

Hydraulic Pump Will Not Turn

Turn hydraulics off, go to the **SureFire PWM valve** and use the manual override (red knob) on top of the electric coil to **manually open the valve** (Manual Override UP = valve fully open). There may be dirt in here that needs to be cleaned out before you can turn and raise the override. Turn hydraulics on **at a low flow only** as the valve is 100% open. If pump does not turn, try hydraulic lever in opposite direction. Does the pump turn? If it turns, your problem is electric / electronic. If the pump still does not turn, you have a hydraulic problem.



Electric / Electronic Problem

1. Close manual override (lock down)
2. Go to **Diagnostics, Calibrate PWM Limits Test** to investigate this issue (this is a place where you can turn the pump on).
3. Verify hydraulics are on.
4. Start test. Hold down “+” button for several seconds. A single tap of this button produces a very small change in signal to the valve, so you must hold it.
5. Take a metal object and hold it next to the coil. If the coil is working, you will feel the magnetic pull. The coil should also show 7 to 9 ohms between the two pins on the electrical connector to the coil.
6. If no magnetic force is felt, disconnect the PWM valve connector and check voltage. You will need 6-12 volts to get hydraulic valve to open.
7. If 6-12 volts is not present on the PWM connector, check harnesses and review control valve type setup.
8. Go back to the 12-pin connector that plugs into the Pump harness. Check voltage between pins 5 & 6(or 2).
9. Go back to the 47-pin connector (if present). Check voltage between pins 23 & 24 for Product 1 PWM; pins 25 & 26 for Product 2 PWM). This should be between 6-12 volts after holding “+” button.
10. At 35-pin connector on ECU, PR 1 PWM—pins 23 & 35; PR 2 PWM—pins 13 & 24). Contact your John Deere dealer for further assistance.
11. You can remove the electromagnetic solenoid with proportional valve to see if the valve moves when a PWM signal is sent to it.

Hydraulics Problem

1. Leave the manual override open on the SureFire valve.
2. Check the hose routings. The “P” port on the SureFire valve should hook to pressure. The “T” port is the return that should flow back to the tractor.
3. Try hoses in a different hydraulic remote. Inspect hydraulic connectors for damage or restrictions.

Hydraulic Manual Override

Down - Normal Operation

Up - Override, valve 100% open

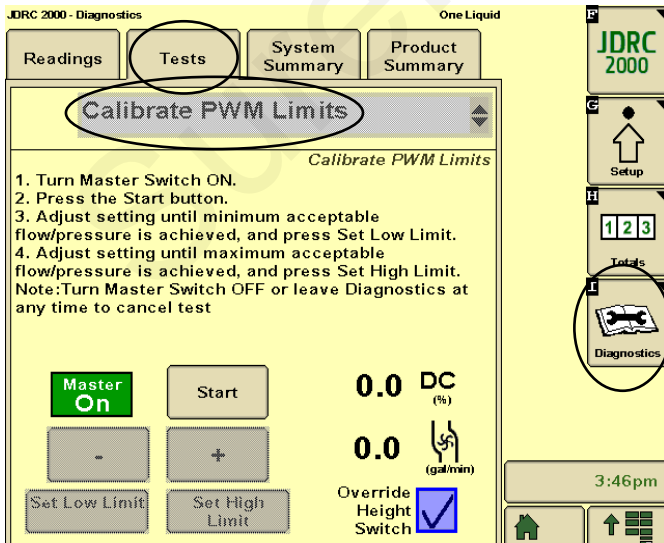
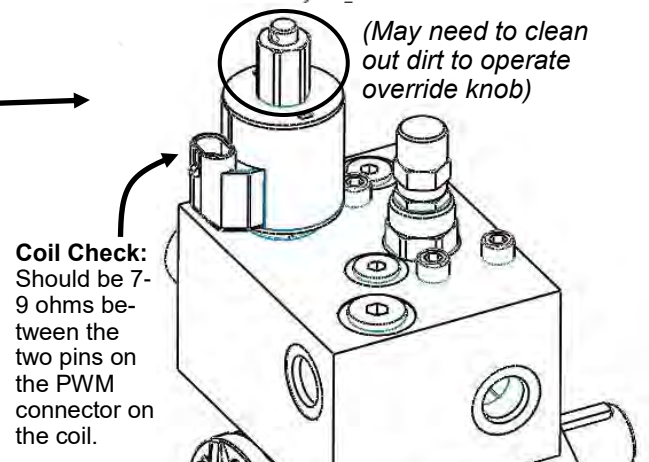
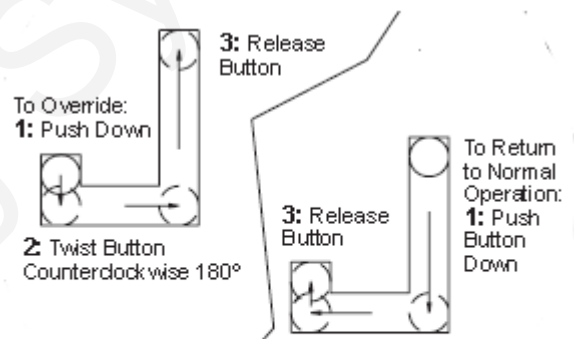

The **Section Test** is another place to run the system. Or, enter a Test Speed and run the system in Manual Mode from the Run Screen.

Tests > Nozzle Flow Check is a good screen to try a Speed and Target Rate to see if it will lock on to a rate. *When testing with water, the pressure will be a lot less than it will be when using a fertilizer product.*

You can also enter a Test Speed and run the system in Auto Mode from the Run Screen.

Application Rate Fluctuates

First, you need to determine if the fluctuation is caused by the controller sending fluctuating signals to the valve or because of something else.

1. **Inspect & clean pump inlet strainer.** Strange flow rate fluctuations are very often due to an obstruction to the pump inlet. Inspect plumbing from tank to pump.

OR

1. Run the system in Manual Mode with a Test Speed or **Diagnostics > Tests > Calibrate PWM Limits.**
2. Turn the system on. Watch the flow in GPM. **Does the system run steady in Manual Mode?**
3. Is the flow steady within a very small range? For example, a fluctuation from 12.3 to 12.7 GPM would be considered normal. A fluctuation from 10-14 GPM is a problem. If only a small normal fluctuation is seen in section test, skip steps 4-8 and proceed to "Application Rate Fluctuates in Field " below.
4. If there is a large fluctuation, observe the system flow. Is the discharge a steady stream; are the flow indicator balls floating steady?
5. If visually the flow is steady, but the display reports a fluctuation in GPM, inspect the flowmeter. See section B of manual for flowmeter information. Check connections between tank and pump. A loose connection may not show up as a leak, but it can be a place where air can be sucked in. Air in the system will cause erratic flowmeter operation.
6. If visually the flow is unsteady, the flowmeter is working correctly reporting a flow problem. Is the pump turning steady or surging?
7. If the pump is turning steady, the hydraulic circuit is functioning correctly. Look for any type of obstruction in the pump inlet. Clean the strainer. If continually plugging the strainer investigate fertilizer quality and necessary strainer size.
8. If the pump speed is surging, there is a hydraulic problem.

Application Rate fluctuates in field, but flow in Section Test mode is stable.

This problem indicates the valve calibration needs changed. The system is surging because the Rate Controller is moving the hydraulic valve too much.

1. Go to **Setup > Settings > Control Valve Setup.**
2. Lower the Valve Response Rate by 5 or 10. Continue lowering if needed. You can do this on the go and see how the change affects the rate. If you get too low, the system will be slow to respond to rate or speed changes.
3. In extreme cases, it may be necessary to go to Advanced Tuning and adjust some other parameters.

Application Rate is slow to get to the Target Rate

1. To get system to Target Rate faster on startup, go to **Setup > Settings > Control Valve Setup > PWM Setup > PWM Startup.** Set PWM Startup (%) so that pump starts up at or slightly above the normal PWM Duty Cycle.
2. If system is slow responding to rate or speed changes, you may need to increase the Valve Response Rate. Go to **Setup > Settings > Control Valve Setup.** Increase Valve Response Rate 10 at a time. You can do this while going across the field and observe the effects of each change. If Valve Response Rate is at 100 and system is still slow getting to Target, go to Advanced Tuning and increase P and S.

Helpful Operating and Troubleshooting Information on the JDRC 2000

1. **Flow (gal/min), Pressure (PSI), PWM Duty Cycle (DC%), and Pump RPM** (if equipped on your hydraulic pump) are important indicators of system performance. It is good to know what these values are in normal field operation. They provide good troubleshooting information if there is a problem.

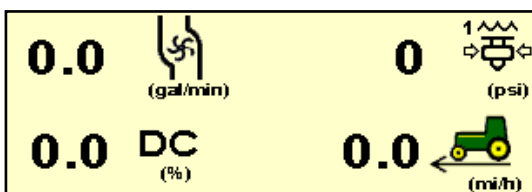

2. These items can be placed on the Run Screen with Display Settings or can be placed in the bottom two windows on the Run Screen.

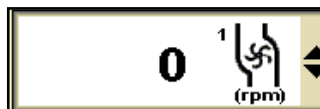

No Flow shown on display, but liquid is being pumped

Flowmeter Tap Test

See which flowmeter connector you have



Remove red guard to reach pins. Don't break red side clips.

Flowmeter pinout:

3-pin MP Tower	A- Signal	B- 12V Power	C- Ground
3-pin AMP SuperSeal	1- Ground	2- 12V Power	3- Signal

1. Unplug the flowmeter. With voltmeter, check for **12 volts between Power & Ground** of flowmeter connector. Should have **4-5 volts between signal and ground**. If voltage is not present, inspect wiring harness and check for voltage at harness connection(s) nearer the Rate Controller (at 12-pin Deutsch connector, Power is 1, Ground is 2, Flow Signal is 3).
2. If 12 volts is present, then conduct a **tap test**. Go to **Setup > Settings > Flow/Rate Sensor Setup** and change the flow cal to 1. Have a second person watch GPM on the 1,2,3 screen while other person taps repeatedly (use a short piece of wire or a paper clip) between signal and ground pins of flowmeter connector. A flow value (gpm) should show up indicating the wiring is not damaged. (If alone, note or reset a volume counter to 0, and start Calibrate PWM Limits Test. Check for increased volume after tapping.)
3. If the flow showed on the display during the tap test, your wiring to that point is good. If tap test did not work, go back to the next harness connection and do a tap test there between signal and ground.
4. If the tap test registers flow on the display, replace flowmeter. (*Sometimes, cleaning the inside tube of the flowmeter with soapy water and a soft brush will remove a film covering the electrodes.*)
5. Change Flow Cal back to appropriate Flow Cal when finished with Tap Test.
6. SureFire has a Speed/Flow Simulator (PN 219-01462) or a Tap Tester (212-03-3912Y1) that can be used to confirm if the wiring is good between the flowmeter and controller.

Field Verification of Flowmeter Calibration

Always verify the flow cal setting by comparing the amount actually applied in the field (from weigh tickets) with the amount shown on the display. Adjust the flow cal as needed to get less than 1% difference between the actual amount applied and the amount shown on the display.

In general:

Increase the Flow Cal number if not enough product is actually being applied. (If you want more, increase the number)

Decrease the Flow Cal number if too much product is being applied. (If you want less, decrease the number)

Formula to Adjust Flow Cal Number

$(\text{Volume shown on display}) / (\text{Volume actually applied}) \times \text{flow cal number in display} = \text{new flow cal}$

Example: Display shows 727 gallons was applied. Weigh ticket shows 750 gallons was actually applied. Flow cal number in display was 3000. (*We applied too much, so we will decrease the flow cal.*)

$$727 / 750 \times 3000 = 2908 \text{ (new flow cal number to set in display)}$$

(Any adjustments to the flow cal number will only be as accurate as the measurements used in figuring it.)

Do not power wash the flowmeter.

Unplug the flowmeter before welding on the implement.

Section Valve(s) will not move

1. Go to **Diagnostics > Tests > Section Test** to investigate this issue. If system shuts off with Solution Pump Dry warning, use the Calibrate PWM Limits Test.
2. Start Section Test. Check and uncheck the boxes. With the box checked the valve should turn on. The valve should be off with the box not checked.
3. If none of the valves are working, or if half of the valves are working, it may be a Power (or Ground) issue. The odd-numbered sections have one power source, the even-numbered sections have another power source. (See harness diagrams)

Pin	Function
A	+ 12 V Constant
B	Ground
C	+ 12 V Signal

4. If a valve does not open, switch the connector that is plugged into that valve with a connector that is plugged into a working valve. Also, plug in the connector to the non-working valve to a valve that is working.
5. Check the harness connection to the non-working valve. It is a 3-Pin Weather Pack connector. Check voltage pin A to Pin B. Must be 12 volts, if not, go back to the next harness connection and check the voltage there. (See harness diagrams for pins)
6. If voltage is present on pins A&B of 3 pin connection to valve, then check Pin C to Pin B. This should be 12 volts when the valve is commanded on or open. This should be zero volts when valve is off or closed.
7. If signal voltage is not present to open valve, use diagrams to check at the 14-pin connector, then the 47-pin for voltage on the proper pin for that section.
8. If harnesses and voltages are good, but valve still will not open, remove the actuator from the valve and see if the actuator will work when it is not connected to the valve. Use a wrench to turn the valve to be sure it is moving freely. Be sure actuator and valve are oriented correctly when you put them back together.
9. If constant voltage (Pins A&B) and switched voltage (Pins C&B) are present, inspect, repair or replace the valve.



This is a 3-way valve. If product will not flow when valve is ON, either move the outlet hose to the other outlet port, or remove actuator and rotate valve ball 180°, and replace actuator. Product should flow through the port closest to the Indicator light when the valve is open (green).

Pressure Sensor is not reading

1. Be sure the Pressure Sensor that is displayed on your screen is the same sensor that is plugged into your harness for that product (Sensor 1 or Sensor 2).
2. Make sure the pins where the harness screws on to the end of the sensor have not been bent.
3. Be sure Pressure Sensor is set up and calibrated in the display. Unplug the pressure harness before doing this.

Setup > Settings > Pressure Sensor Setup. Select the sensor you want. > Calibrate Pressure Sensor > Voltage-based Calibration > 50 mv/PSI.

4. There should be a green LED light on the end of the pressure sensor. This may be difficult to see in daylight. The sensor needs 12 v. Check between pins B&C on the Pressure connector on the harness that connects to the pressure sensor. If there is no voltage here, check the voltage between pins 1 & 2 on the 12-pin connector labeled PUMP.
5. **Testing Pressure Sensor Harnessing:** If the pressure sensor is not reading, you can use a AA or AAA battery to test the harnessing. Connect the (-) end of the battery to pin C and the (+) end to pin A of the pressure connector. The 1.5 v should show up as 30 psi on the screen. You can check this at *Diagnostics > Readings > Pressure Sensors*. (0 PSI should be 0.0v)

Other issues

1. “My rate won’t go low enough. I want 8 gpa, but it won’t put down less than 11 gpa.”

- Check **Setup > Settings > Flow/Rate Sensor Setup > Minimum Flow Rate**. This can be set at 0.0 or at the low range of your flowmeter. This is **gal / min** not **gal / acre**.
- Check **Setup > Settings > PWM Setup > PWM Settings > Low Limit**. Default setting for JD is 10 for electric pumps and 25-30 for hydraulic pumps. You may need to lower those. If set too high, the pump cannot slow down enough when your speed drops or when sections close.
- On a hydraulic pump, be sure the red manual override knob is down and locked on the hydraulic valve.
- Check to see if a **Pressure Sensor is assigned** to this product, and if a **Minimum Alarm is set**. If the **box is checked** for a Minimum Pressure, the system will not go below that pressure.

2. “I can’t get up to my rate. I want 12 gpa, and I can’t get more than 10 gpa.”

- How many GPM are required to hit your rate? Is this within the pump’s specifications? On an electric pump, **the output of the pump decreases as the pressure increases**. Keep the pressure under 40 PSI (or lower) on an electric system. Is a **recirculation valve** open, allowing too much liquid to recirculate?
- On a dual electric pump system, **check each pump individually** to see that each one is working at capacity.
- Is the strainer plugged?** If too small of a mesh strainer is being used, the fluid can gel up around the screen as the fluid is pulled through, even if the strainer appears clean. Most SureFire systems with metering tube and electromagnetic flowmeter can use a 20– or 30-mesh strainer.
- Does the pump have **enough hydraulic oil** to hit the desired rate? If the pump is in series behind another pump or motor, the hydraulic oil to this pump may be limited. Is the hydraulic flow set high enough?
- Compare the **PWM Duty Cycle DC%** and **Pump RPM**. The pump should be able to reach it’s rated output at 500 RPM. Run the pump with the **manual override UP**. Start at low hydraulic flow. Gradually increase hydraulic flow and watch GPM and Pump RPM. The solenoid or proportional valve on the hydraulic valve block may need to be replaced if they are not opening all the way to allow full hydraulic flow.
- If a **Maximum Pressure Alarm** is set and the box is checked for a Pressure Sensor assigned to this product, the system will not go above that pressure.
- Check **Setup > System > PWM Setup > PWM Settings > High Limit**. This should normally be 100.
- Check the **PWM DC % (Duty Cycle)**. This can be placed on the Run Screen.
- Run the pump with a Test Speed in Manual Mode. Press the + button to increase flow. Observe flow (GPM), PWM DC%, PSI, and Pump RPM (if equipped).
- Run a Nozzle Flow Check. See gal/ac, PSI, gal/min, Pump RPM and PWM Duty Cycle.
- Is the flow cal correct? Is the width of the implement set correctly?

3. “It’s pretty close to the rate, but it won’t ever lock in to the rate.”

Go to **Setup > Rates > Rate Smoothing**. Check the box for Rate Smoothing. Put **10** in the box.

Without Rate Smoothing it is normal for the system to show the rate constantly changing small amounts as you go across the field. With Rate Smoothing, if the Applied Rate is close to the Target Rate, the display does not show all the small changes.

If the **Control Deadband** is too small, this may cause the system to oscillate as it tries to correct for every small variation from target. Try increasing the Control Deadband to see if this helps. (Normal is 2)

If the **Valve Response Rate** is too high, the system may overshoot back and forth across the Target Rate.

4. “When I start up, I get a screen that says “Solution Pump Dry”.

This is not unusual on the Deere display. If the flowmeter does not show flow immediately when you start, this screen pops up. It is made to protect centrifugal pumps that can be harmed quickly if they are dry. This is not a problem for SureFire diaphragm pumps. To get to Target Rate quicker on startup, **set the PWM Startup %** so the pump starts at or slightly above where it will be running.

Also, to help eliminate the Solution Pump Dry screen, **assign a pressure sensor to this product**. If the system reads pressure, it will assume there is flow and will not give this warning.

5. “What settings do I use for the SureFire system on the original JD Rate Controller?”

The full screenshots of these are in Section F of the manual that came with the system.

The manuals are available at www.surefireag.com/support.

6. “My pressure is too high / too low.”

The pressure will be what it is depending on how hard it has to push to get the amount of liquid you are moving from the pressure sensor to where it leaves the system. This pressure will depend on the product itself, the volume (gal/min) you are moving and how much restriction there is to that flow. The orifice or metering tube will be the primary restriction, but it is possible that other parts of the system may add to the total pressure. 1/4” tubing can build a lot of pressure with 10-34-0. The pressure a system develops will be less (possibly much less) with water than it will be with a fertilizer product.

What pressure is “too low”?

You need enough pressure to open the check valves. If the pressure is too low, some check valves will open before others, so that some rows may be flowing while others are not. **With 4 lb check valves, we like at least 8 PSI. With 10 lb check valves, we like 15-20 PSI.**

What pressure is “too high”?

A pressure is too high if it keeps the system from being able to hit the rate you want or if it opens the PRV (Pressure Relief Valve) on a hydraulic pump.

The plumbing components of a SureFire system are rated at 100 PSI or above. On an electric pump system, the pump capacity decreases as the pressure increases. Our standard Tower pump has an internal 70 PSI bypass. **With an electric pump, we like to see pressures from 10 to 30 PSI.** If the pump has the capacity to hit the rate at higher pressures, there is not a problem with doing that, but for long-term operation it would be best to switch to a larger orifice or metering tube.

The SureFire PumpRight hydraulic pump has the ability to pump up to 290 PSI. SureFire plumbs these with a 100 PSI pressure relief valve (PRV) so that plumbing components will not be damaged if high pressure develops. **Typical operating pressures with hydraulic pumps will be 20-60 PSI,** but the pump will work fine at 80-90 PSI if that is needed. If continually running in that high range, consider a larger orifice or metering tube.

Lower pressure will not necessarily reduce the **velocity of the output stream** at the row. Conversely, higher pressure will not necessarily increase the velocity of the output stream at the row. The velocity of the output stream is determined by the volume of the flow and the size of the opening at the output. Changing the pressure by changing an orifice or metering tube upstream from the outlet will not affect the velocity of the output stream if the flow volume remains the same.

Options if pressure is too high with orifices: Use a bigger orifice. Slow down. If pressure is too low, use a smaller orifice.

With metering tube: Options if pressure is too high: Use a larger diameter tube. Shorten the tubes that are on now. Slow down. *(The pressure in a metering tube is related to the viscosity of the product. Many products change viscosity as the temperature changes. A product will have a higher viscosity (and therefore higher pressure) on a cold morning that it will on a hot afternoon.)*

With metering tube: Options if pressure is too low: Switch to a smaller diameter tube. Use a longer tube.

7. How do I set the Recirculation knob? Generally, the recirculation knob is closed. If tank agitation is necessary while applying, the recirculation hose can be plumbed back to the tank. Electric pumps do not have the capacity to do much agitation. A small amount of recirculation may be desired if the pump needs to run slowly and the output is not smooth. Start with a quarter turn of the knob (less on an electric pump). A half turn of the knob will recirculate a lot. If too much is recirculated, the pump may not be able to hit the rate to the rows. Opening recirculation will not lower the pressure required to push the desired product to the rows. *If much recirculation is used, it may be best to direct it back to the tank rather than back to the pump inlet.*

See SureFire publication [“396-3269Y1 Navigating the Metering Tube Maze”](#) or [“396-4116Y1 Metering Tube Charts”](#) for more information on how metering tube works.

See SureFire publication [“396-3229Y1 Liquid System Components Overview”](#) and [396-3613Y1 Troubleshooting for JDRC 2000](#) for a description of all the system components and additional troubleshooting/service information.

See the system manual for your system for more complete information at www.surefireag.com.

Also see the John Deere manuals for the John Deere Rate Controller 2000 for more information on the setup and operation of those components.



Recommended Care and Maintenance



Air Bladder

PumpRight pumps (PR 40 and D250) have an air bladder to smooth the pump output flow. It is recommended to run this bladder at the greater of 15 PSI or 25% of working pressure. Due to the small size of the air bladder, **very little air is needed**. SureFire recommends charging a portable air tank to the correct pressure, then attach to the bladder valve to charge the air bladder to the same pressure as your air tank.

Winterization

SureFire recommends flushing your fertilizer pump and complete system with adequate amounts of water first. Next, use RV antifreeze to winterize your system by pumping an adequate amount through all components. At the beginning of the next season, begin with water to verify the system is in working order with no leaks.

Change Pump Oil Annually

PumpRight pumps use an internal oil lubricated crankshaft and connecting rod design. The oil is held in an external reservoir with level indicators. SFA Part #: 291-02-2160-0038 oil is recommended for the pump, supplied by SureFire Ag. This is a non-detergent SAE30 weight oil. If not available, hydraulic jack oils are a similar non-detergent formulation. Annual oil changes are recommended.

To fill or drain the pump completely, the pump shaft must be turned slowly by hand. The hydraulic motor will have to be removed to do this.

On some pump models, the pump will have to be removed from the mounting bracket and lifted slightly to allow access to the oil plug.

When refilling the pump with oil, the shaft will again have to be rotated to fill the pump to its required oil volume.

CRANKCASE OIL CAPACITIES				
Model	Capacity		Model	Capacity
PR17	13 oz		PR40	56 oz
PR30	28 Oz		D250	98 oz

Diaphragm & Valve Replacement

PumpRight pumps are designed to allow very simple replacement of the two main pumping components; the diaphragms and the inlet & outlet valves. It is a good practice to replace these every 3 or 4 years (or every 1000 hours). It is a small job that helps ensure reliable operation during the busy season.

PumpRight Valves & Diaphragms



Diaphragm Pump Service Kits

1 Kit contains 1 diaphragm and 2 valves to service a single pumping diaphragm.

Order multiple kits to service all the diaphragms in your specific pump per chart below...

[Visit www.surefireag.com](http://www.surefireag.com) or www.support.surefireag.com for [PumpRight Diaphragm Pump Repair and Maintenance Video](#)

QTY in Kit	Part Number	Description
PR17 Pump Service Kit - 3 Diaphragm		
KIT #: 291-13-100100 (pump requires 3 kits)		
1	291-13-1040083	BlueFlex Diaphragm (PR17)
2	291-13-2429051	Valve
2	291-13-3460380	Gasket/O-ring

PR30 Pump Service Kit - 3 Diaphragm		
KIT #: 291-13-100150 (pump requires 3 kits)		
1	291-13-550081	BlueFlex Diaphragm
2	291-13-2429051	Valve
2	291-13-3460380	Gasket/O-ring

PR40 Pump Service Kit - 4 Diaphragm		
KIT #: 291-13-100150 (pump requires 4 kits)		
1	291-13-550081	BlueFlex Diaphragm
2	291-13-2429051	Valve
2	291-13-3460380	Gasket/O-ring

D250 Pump Service Kit - 6 Diaphragm		
KIT #: 291-13-100200 (pump requires 6 kits)		
1	291-13-550081	BlueFlex Diaphragm
2	291-02-9910-759051	Valve
2	291-02-680070	Gasket/O-ring

For other service parts, see individual Pump Part Breakout Diagrams in [396-4034Y1](#), the PumpRight manual that came with your pump.

[Also see the manual and individual pump parts breakouts online here.](#)



PumpRight Valves & Diaphragms

Diaphragm Pump Service Kit Replacement Instructions for PR Pumps

Visit www.surefireag.com or www.support.surefireag.com for PumpRight Diaphragm Pump Repair and Maintenance Video



	Number of Diaphragms
PR17	3
PR30	3
PR40	4
D250	6

Diaphragm & Valve Service Steps:

1. Remove inlet and outlet plumbing connections by unscrewing ring nut on inlet and outlet fitting.
2. Use extreme caution when removing and replacing drain plug, so that threads are not stripped and o-ring is not damaged. Remove drain plug from bottom of pump to drain oil from pump. Rotate pump shaft to remove all oil. Replace drain plug making sure o-ring is in place. Tighten plug to 180 In.Lbs.
3. Remove pump manifold(s) using a 13 mm wrench.
4. Remove and replace complete valve assembly.
5. Remove the pump head.
6. Remove the diaphragm bolt, support washer and diaphragm. Turn the pump shaft to up stroke to replace diaphragm.
7. Install new diaphragm (LIQUID side up), then replace washer and bolt.
8. Turn pump to downstroke to seat new diaphragm into the sleeve groove.
9. Replace pump head and manifold(s).
10. Refill crankcase with SAE30 non detergent oil (PumpRight Oil or hydraulic jack oil). Turn the pump shaft and top off sight glass.

NOTE: See individual Part Breakout Charts for Bolt/Nut Torque Specs.

Typical Manifold—2 per pump—inlet and outlet

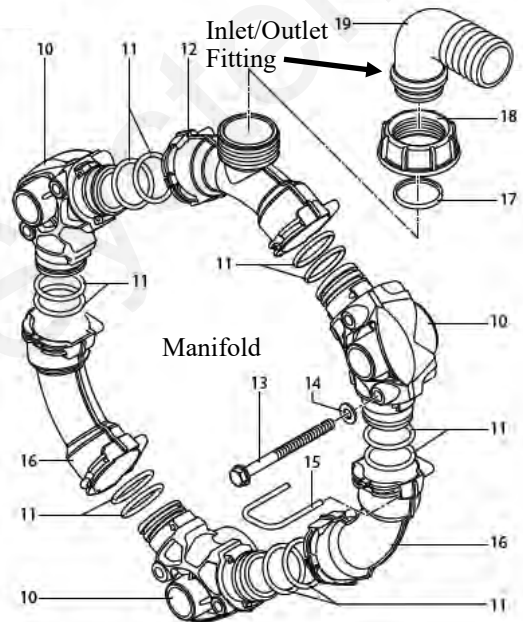

Typical Valve Assembly

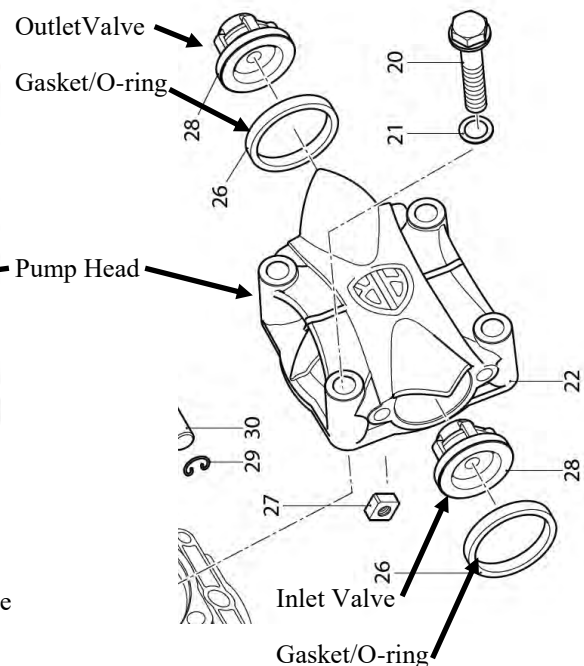

Typical Diaphragm Assembly

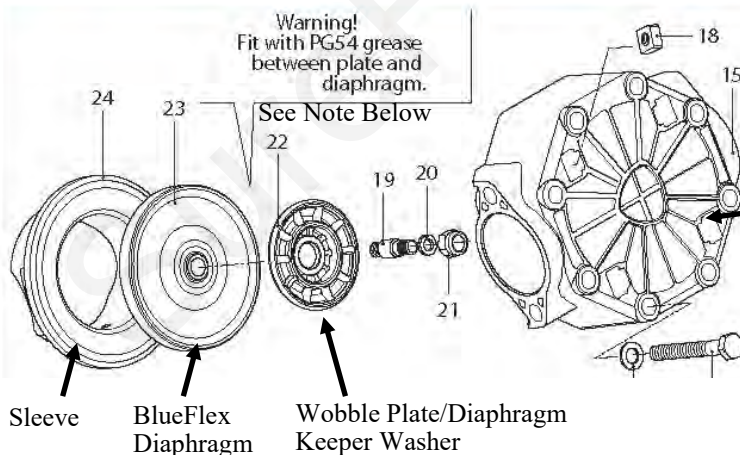

NOTE: A multipurpose grease is fine to use for applying in between the Diaphragm and Wobble Plate/Washer

For other pump service parts, see individual Pump Part Breakout Diagrams in [396-4034Y1](#), the PumpRight manual that came with your pump.

[Also see the manual and individual pump parts breakouts online here. \(store.surefireag.com\)](#)

[Go to support.surefireag.com for pump information and parts breakdowns.](#)

PWM Valve and Motor Parts

H

Maintenance
& Parts

- 164-FTA0994 4.0 CID motor (this is the standard motor beginning in 2016)
- 164-FTA1609 Same as 164-FTA0994, but with RPM Speed Sensor--
GRC does not support a Pump RPM sensor.

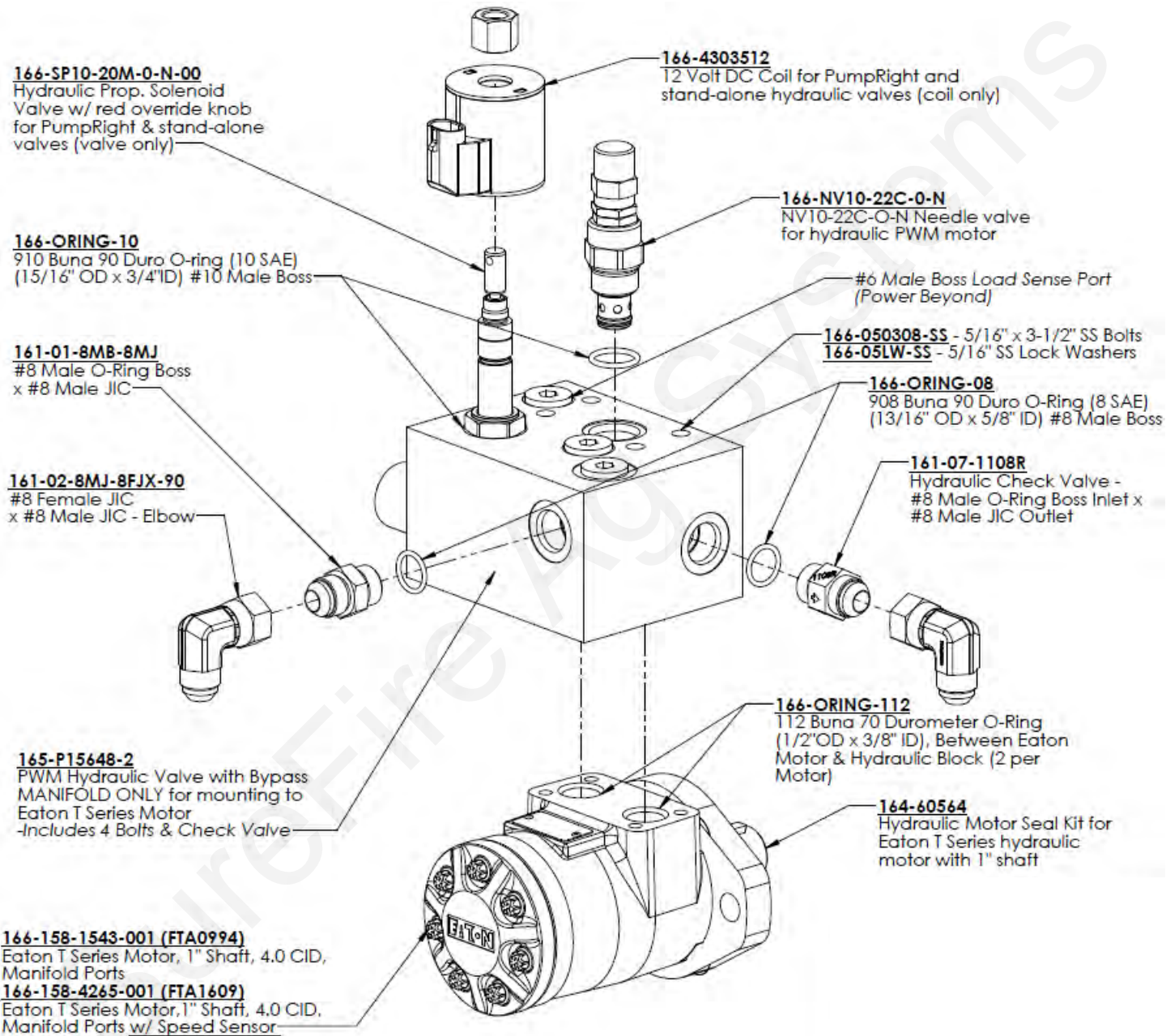

Pre-season Service

(A little time spent here may prevent some downtime when you want to be rolling.)

1. Visually check entire system (hoses, fittings, harnesses, etc.) for any signs of wear or trouble.
2. On the display, recheck all setup screens (see Section F) to verify correct setup.
3. Fill system with water and run in Manual mode (Section Test or Calibrate PWM Limits Test) to verify components and system are in working order. (May need to open air bleed valve to prime pump the first time. Be sure air bleed tube is not plugged.)
4. Clean out the dirt that may be packed in to the manual override knob on the hydraulic valve block. Be sure manual override knob can be operated in case it is needed for troubleshooting. The knob should be pushed down and locked for normal operation.
5. If necessary run pump in manual override mode to check hydraulic setup (see page 41).
6. Tighten all clamps. Loose clamps may be evident by leaks on the output side of the system. Loose clamps from the tank to the pump are not always apparent, but can be sources of air getting into the system which can create issues.
7. Push in tubes at all Quick-Connect fittings so they are seated tightly. Tubes that are not fully seated are not always obvious, but may allow air in, which can cause check valves to leak.
8. Remove the black cap from the top of each check valve. Check the diaphragm to be sure it is intact and not gummed up with residue. Look under the diaphragm for debris. Compress the spring in the cap to be sure it moves freely. Carefully replace diaphragm and tighten cap.
9. Remove and clean the strainer. Be sure strainer is tightened securely so it will not suck air.
10. Be sure all rows are flowing and that all metering tubes/orifices are open. (Note: It will take a higher flow rate with water to create enough pressure to open all the check valves.)
11. Run the Nozzle Flow Check to verify that system will lock on to a Target Rate.
12. Check, and if necessary, tighten the tank straps.

H

Maintenance
& Parts



▲ DANGER

Hydraulic oil under extremely high pressure. Do not use hand or any other skin to check for or to stop hydraulic leaks. Be sure pressure is relieved before loosening hydraulic fittings. Replace worn hoses immediately. Seek medical care immediately if hydraulic oil is shot into the eye or the skin.



▲ CAUTION

These pumps can deliver liquid at high pressure (290 PSI). Be sure the 100 PSI Pressure Relief Valve (PRV) is installed and functioning so system pressure will be kept under 100 PSI. Check hoses, hose clamps, and liquid fittings regularly and repair or replace loose connections.