

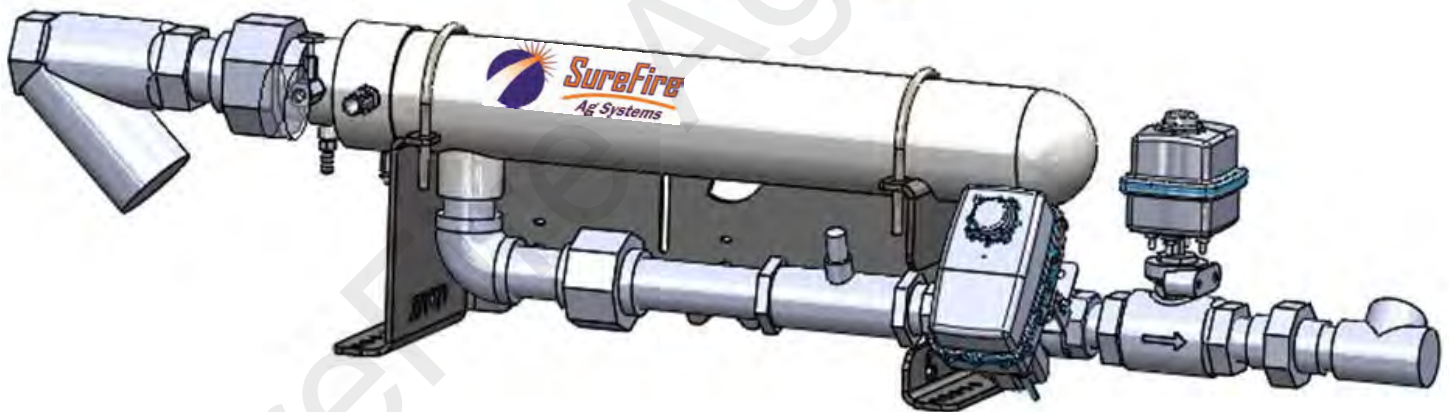

NH₃

Precision Anhydrous Ammonia

Application for



396-2852Y1



SureFire
Ag Systems



Table of Contents

Section A—Introduction	2
Anhydrous Ammonia (NH ₃) Safety Precautions.....	2
Things to Know About Anhydrous Ammonia	3
Anhydrous Ammonia Application Overview	4
Section B—Components—Liquid and Vapor.....	5
Sizing System Components-Torpedo Model 100, 200, or 300	6
System Overview with 4 Electric Section Valves-Model 100 or 200	7-8
System Overview with Torpedo Model 300	9
Installation and Setup Instruction Tags.....	10
Tank Valves.....	11
Globe Valve Assemblies.....	12
Breakaway Disconnect	13
Torpedo SuperFlow Assembly.....	14-16
Splitters and Manifolds	17-21
Dump Hose Barbs and Dump Orifice Hose Barb.....	22
Flowmeter.....	24-25
Electric Section Valves and Splitter Kits	26-29
Gauge Tree Assembly	30
Section D—Controller Setup and Wiring Harnesses	31
Ag Leader Controller Setup	31-35
Wiring Harness Diagrams.....	36-38

The components of your system may vary from the components shown in this manual due to different configurations and locations of valves, splitters, manifolds, and other components. Various configurations are shown in this manual, but not every situation can be covered here.

It is the responsibility of the owner/operator to assure that all necessary components are installed correctly and continue to remain in a safe operating condition.

All personnel operating or working around an anhydrous ammonia system must be thoroughly trained in safe anhydrous ammonia procedures.

Operators of anhydrous ammonia systems should always carry on their person an emergency squeeze bottle of fresh water. There should always be five gallons of clean water available on the nurse tank for immediate flushing in the event of an accidental exposure.

© 2015 SureFire Ag Systems-All Rights Reserved





Anhydrous Ammonia Safety

Anhydrous ammonia is an important source of nitrogen fertilizer for crops. The improper handling of anhydrous ammonia can have catastrophic results on both plants and farm workers. Common injuries are severe burns to eyes, skin and the respiratory tract.

- Personal protective equipment (PPE) should always be worn. Standard PPE should be non-vented goggles, rubber gloves with thermal lining, face shield or an approved respirator. Wear a lightweight rubber suit, or (at the very least) a long sleeve shirt and coveralls.
- Make sure anhydrous ammonia tanks are not filled beyond the recommended capacity.
- Use care when handling the hose end valve so that it does not open accidentally. Do not move the hose by handling valve handle.
- Be sure to bleed the hose coupling before disconnecting. Use care when cleaning plugged knives as anhydrous ammonia could be built up behind the plug.
- Use emergency water supply for at least 15 minutes if exposed to anhydrous ammonia and then seek emergency medical attention.
- The operator should have a small squeeze bottle of fresh water with him at all times.

Inspection

- Are the hoses in good condition?
- Has the expiration date been passed on any hose or other dated component?
- Are all fittings clean and free from rust?
- Do low-pressure tubes have any leaks?
- Are any knives plugged?
- Is the tank secure with a locking hitch pin?
- Is the pressure relief valve operating correctly?
- Does the tank have five gallons of fresh water?
- Is PPE available and being worn?

BE CAREFUL WITH THIS STUFF!



Things to Know About Anhydrous Ammonia (NH₃)

Anhydrous ammonia is a colorless non-flammable liquefied gas. Its vapor is lighter than air and has the same pungent odor as household ammonia. Although ammonia vapor is lighter than air, the vapors from a leak may hug the ground appearing as a white cloud. Chemically, ammonia is 82% nitrogen (N) and 18% hydrogen (H) and has the chemical formula NH₃. Ammonia by weight is 14 parts nitrogen to 3 parts hydrogen, or approximately *82% nitrogen and 18% hydrogen*.

The definition of *anhydrous* is *without water*. Whereas household ammonia is 95% water, anhydrous ammonia has no water. Ammonia is so hydroscopic (water loving) that one cubic foot of water will dissolve 1300 cubic feet of ammonia vapor making water the primary weapon for first responders.

Ammonia weighs 5.15 pounds per gallon in contrast to water which weighs 8.33 pounds per gallon. Since ammonia is so soluble in water there will be no layering effect when liquid ammonia is spilled into a surface water body. Booms, pads, sweeps and pillows that are usually used to contain and recover petroleum are ineffective on spills of ammonia into surface water.

Ammonia is a non-flammable gas but will ignite at a temperature of 1204°F within vapor concentration limits between 15% and 28%. (Paper ignites at 450°F, coal at 750°F.) Outside conditions that would support these vapor concentrations are very rare.

Ammonia will corrode galvanized metals, cast iron, copper, brass, or copper alloys. All ammonia piping, valves, tanks and fittings are constructed of steel.

Liquid ammonia boils at any temperature greater than -28°F and will expand to 850 times its liquid volume. One gallon of liquid will expand to 850 gallons or 113 cubic feet of gas.

Ammonia Fast Facts

NH₃ Vapor

Ammonia appears in nature as a natural substance that results from decomposition.

Ammonia vapor is a colorless gas with a pungent odor.

Ammonia exists as a vapor at atmospheric conditions.

Ammonia vapor is lighter than air and tends to rise when released to atmosphere.

NH₃ Liquid

Liquid ammonia released to atmosphere forms a white smoke by freezing the moisture in the air.

Liquid ammonia has a very high coefficient of expansion with temperature.

One gallon of liquid ammonia weighs approximately 5.15 lbs.; however the weight varies with temperature.

When liquid ammonia reaches a temperature between its melting and critical points, it exerts a vapor pressure that increases with temperature.

A closed container of liquid ammonia is in equilibrium with ammonia vapor and the container pressure bears a definite relationship to the temperature.

Physical Data

Boiling point is -28°F.

Ignition point is 1,204°F.



Storage and Handling

Ammonia is stored and transported as a liquid under pressure.

The pressure on the tank is the liquid pressure and remains the same whether the tank is 10% full or 80% full. This pressure is dependent on the temperature of the NH₃.

The maximum filling level of an anhydrous ammonia tank is 85%.

Flammability

Anhydrous ammonia is classified by the DOT as a non-flammable gas.

Ammonia vapor is flammable over a narrow range of 15% to 28% by volume in air and a strong ignition source must be present.

Anhydrous Ammonia Application

Precision application of anhydrous ammonia starts with a proper metering system. It is crucial to be sure the metering and control system is applying what is required.

Accurate metering of anhydrous ammonia is difficult to achieve with a conventional variable orifice meter. Anhydrous ammonia is stored and transported as a liquid. To maintain NH₃ as a liquid it must be kept below -28°F or maintained under pressure. If the temperature of the NH₃ increases above -28°F some of the liquid changes to a gas as the NH₃ begins to boil. Application equipment typically uses tank pressure to deliver NH₃ to the soil. An increase in tank pressure would tend to force more NH₃ through the distribution lines. The actual pounds of NH₃ being applied decreases or increases as tank pressure fluctuates unless continuous adjustments are made to the meter.

If NH₃ is released into the atmosphere it will expand rapidly to occupy a volume 850 times greater than the original liquid. NH₃ readily changes from liquid to gas in the nurse tank and distribution system. Consequently the ratio of NH₃ gas to liquid continually changes as it passes through the distribution lines. About 1% of the liquid will vaporize during the ammonia flow from the tank dip tube to the metering point. 1% liquid when expanded to vapor at 100 lb tank pressure will occupy approximately 25% to 30% of the delivery chamber. At 50 lb tank pressure this increases to over 60% of the delivery chamber occupied by vapor. This makes metering and distributing NH₃ very difficult to do consistently and accurately.

Automatic NH₃ controls utilizing the **SureFire Torpedo™ NH₃ System** eliminate the problems found in conventional systems. The first step to accuracy is **eliminating errors caused by vapor** in the system. The second step is **compensating for ground speed and tank pressure fluctuations**. The SureFire Torpedo™ system uses a **heat exchanger to convert the NH₃ to 100% liquid for precise metering**. *With the heat exchanger delivering 100% liquid to the flowmeter, the precise amount needed is metered and delivered.* The controller and control valve will **adjust for ground speed changes** to eliminate misapplications that are common in conventional meter systems. This eliminates guessing and manually adjusting for different tank pressures or rates.

For high volume application, wide implements, fast speeds and cold temperatures the *delivery component pieces are critical for delivering the flow needed*. A flow that can be delivered at 90° may not be achievable when the temperature drops to 40° if the system components are not designed and sized correctly. These pieces include: **Tank withdrawal valve, NH₃ delivery hose and breakaway coupler, and heat exchanger with adequate capacity**. The components of a SureFire system are designed to deliver the flow you need.



After this precise metering the *challenge of row distribution* still awaits. The proper **manifold system** is important for row to row accuracy. The manifold can also be a cause of flow restrictions in high flow applications. The SureFire Torpedo system uses the best in class Continental 360 series manifolds or the Continental Vertical Dam Manifold series.

Setting Up Your System

The following pages show some of the calculations needed to determine the specific components of your SureFire Torpedo™ NH₃ system.

First, the **width, rate, and speed** will be used to determine the amount of NH₃ your system will need to deliver. With this information, the **tank withdrawal valves, NH₃ hose(s), and Torpedo™ heat exchanger** can be selected.

Next, the distribution system will be set up. This takes into account the **row spacing, number of rows, amount of NH₃ per row, and how many sections** there will be. With this information, the **splitter, manifolds, section valves, and hoses** can be selected.

The Smaller Pieces

There are other smaller pieces that are, nonetheless, very important. One of these components is the **hydrostat relief valve**. These are located in segments of the system that may experience a build-up of pressure from NH₃ left in the line.

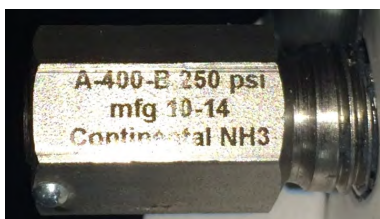

153-A-400-B 1/4" Hydrostat Relief Valve—250 PSI —
(Keep the dust cap on)
Used in various segments of the system
as a safety relief valve.



End view

The Hydrostat relief valve has a Manufactured Date (mfg). Replace 5 years after manufacture.

Bleeder valves are located throughout the system. The operator should be familiar with all the locations and make certain that all parts of a segment are bled off before working on the system.

Some components of your system may have separate Instruction Sheets, Installation Information, or Safety Information. Read all such product literature before installing or operating the system and retain the information for future reference.

Your SureFire Torpedo™ NH₃ system is designed to provide safe, reliable, dependable, and accurate distribution of NH₃. It requires the operator to exercise due diligence in setting up, operating, and maintaining all system components to continue operating safely.

Remember:

BE CAREFUL WITH THIS STUFF!

Sizing System components

The following table shows the flow and application rates that are attainable with each SureFire Torpedo™ model.

SureFire Torpedo™ Model # 100, 200 or 300 Kit

Model #	34 degrees F (50 PSI)		Max App Rate Lbs N / acre		60 degrees F (93 PSI)		Max App Rate Lbs N / acre	
	GPM	Lbs NH ₃ per hour	40' at 8 MPH	60' at 8 MPH	GPM	Lbs NH ₃ per hour	40' at 8 MPH	60' at 8 MPH
100	23	7100	150	100	28	8650	185	120
200	35	10800	230	150	43	13500	285	190
300	50	15450	330	220	64	20000	427	285

Calculating NH₃ Flow

Do the following calculation to determine the proper Torpedo Model for your application:

$$\text{Rate (lbs of N) per acre} \times \text{Speed} \times \text{Width (feet)} \times 0.1212 / 0.82 = \text{NH}_3 \text{ Lbs / hr}$$

$$\text{NH}_3 \text{ lbs/hr} / 60 \text{ min/hr} / 5.15 \text{ lbs/gal} = \text{GPM (NH}_3\text{)}$$

$$\text{Lbs of NH}_3 \times 0.82 = \text{Lbs of N}$$

$$\text{Lbs of NH}_3 = \text{Lbs of N} / 0.82$$

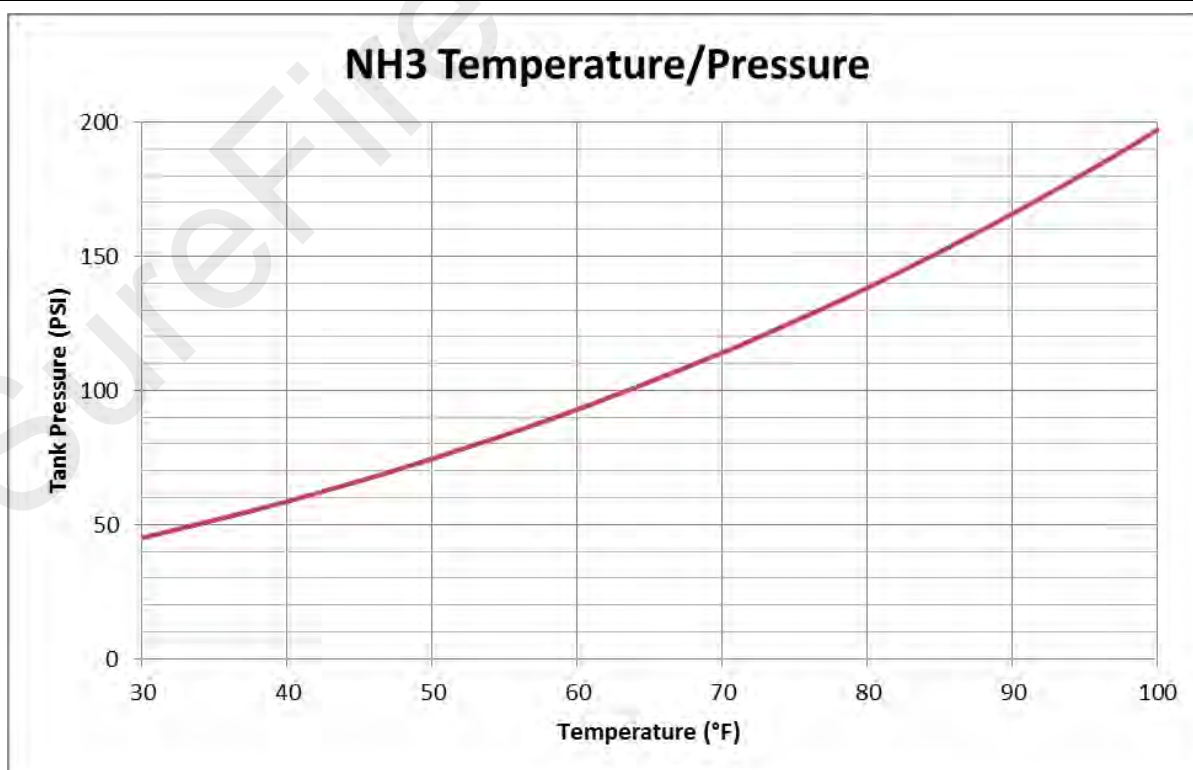

System Overview with 4 electric Section Valves

Torpedo™ Model 100 and Model 200

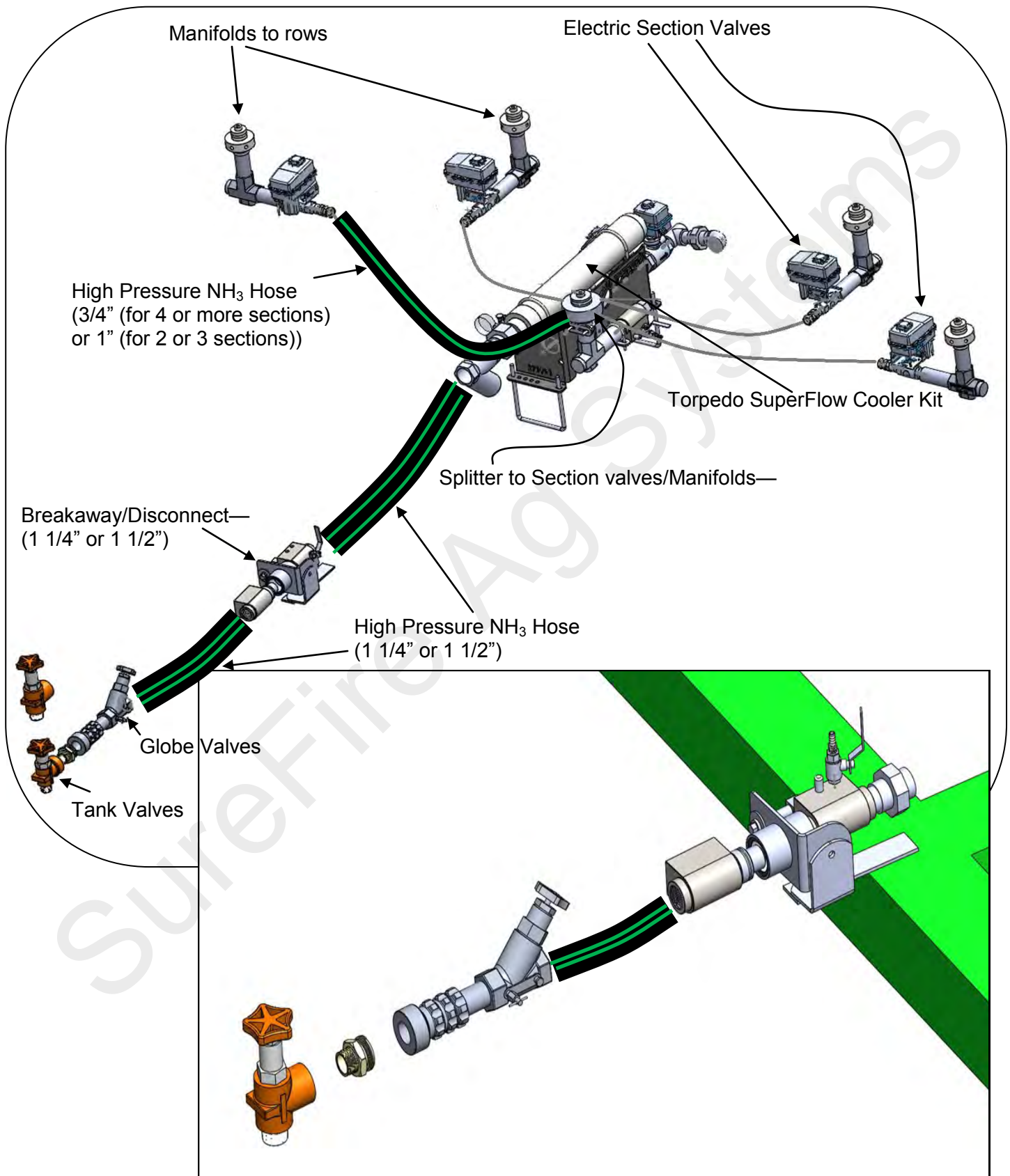

System Overview with 4 Electric Section Valves

Torpedo™ Model 100 and Model 200

Optional Gauge Tree shown

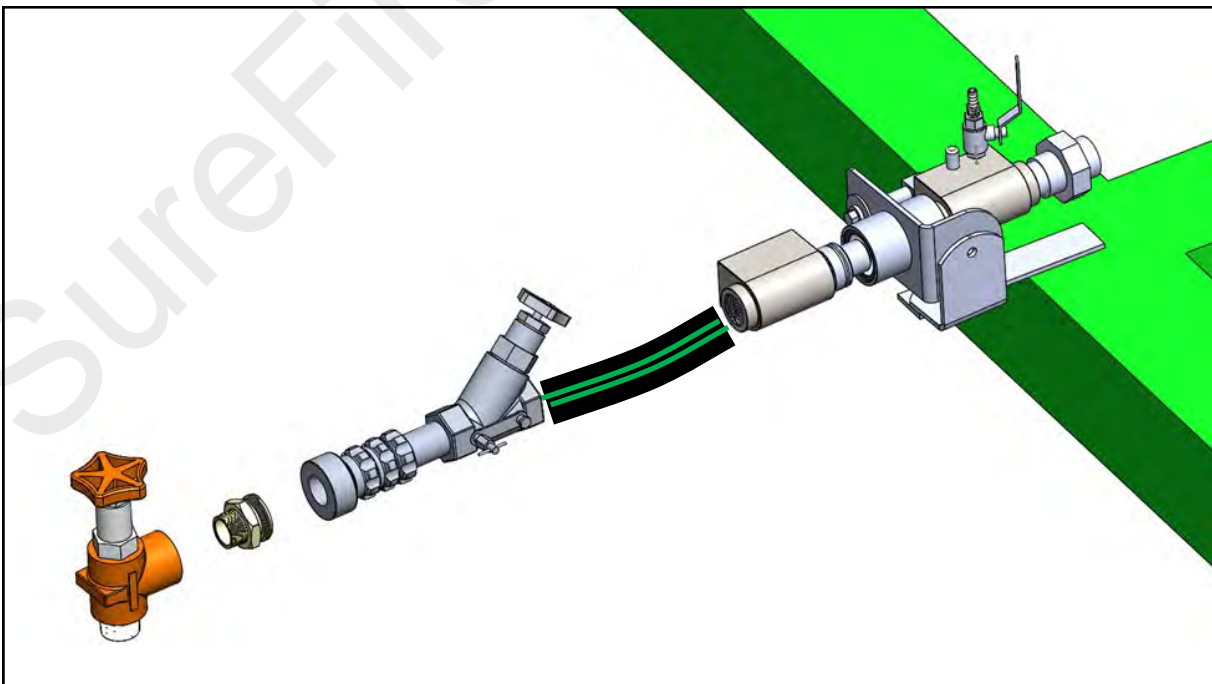
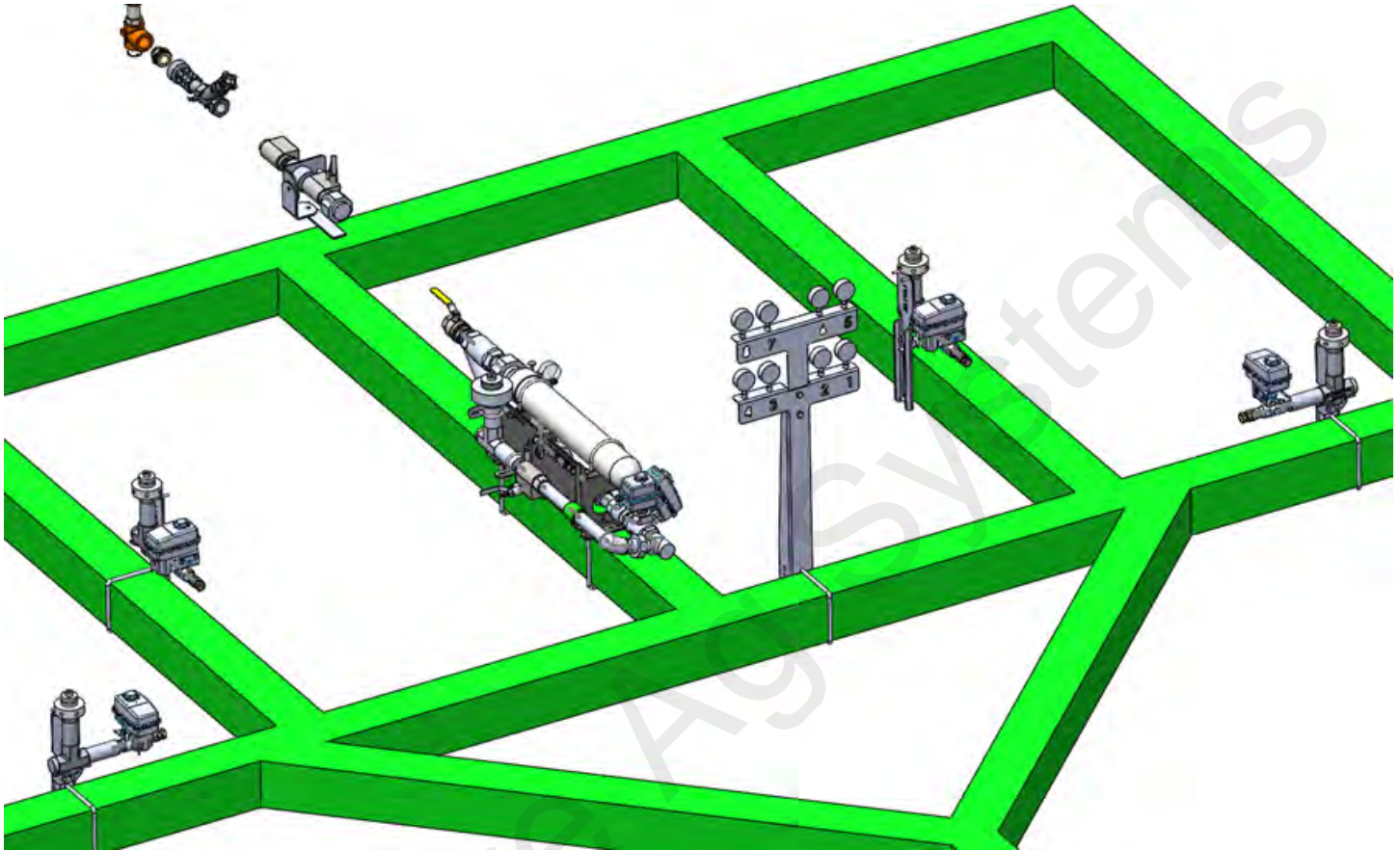

System Overview with Torpedo™ Model 300

159-00-200150

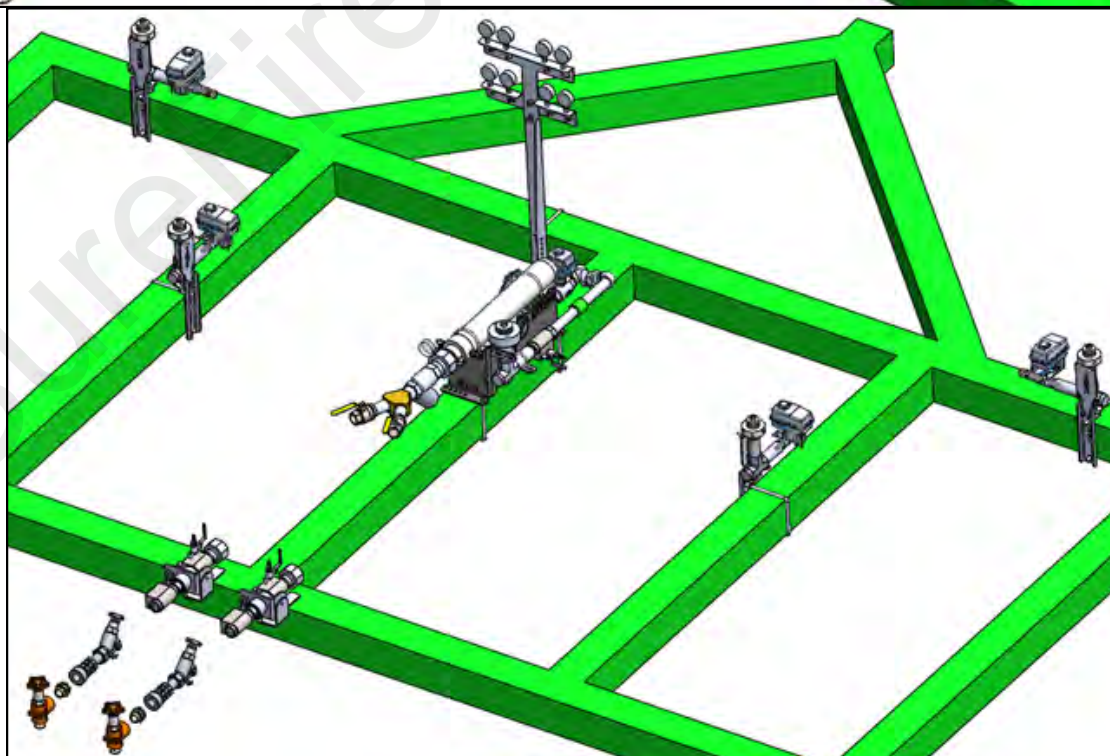
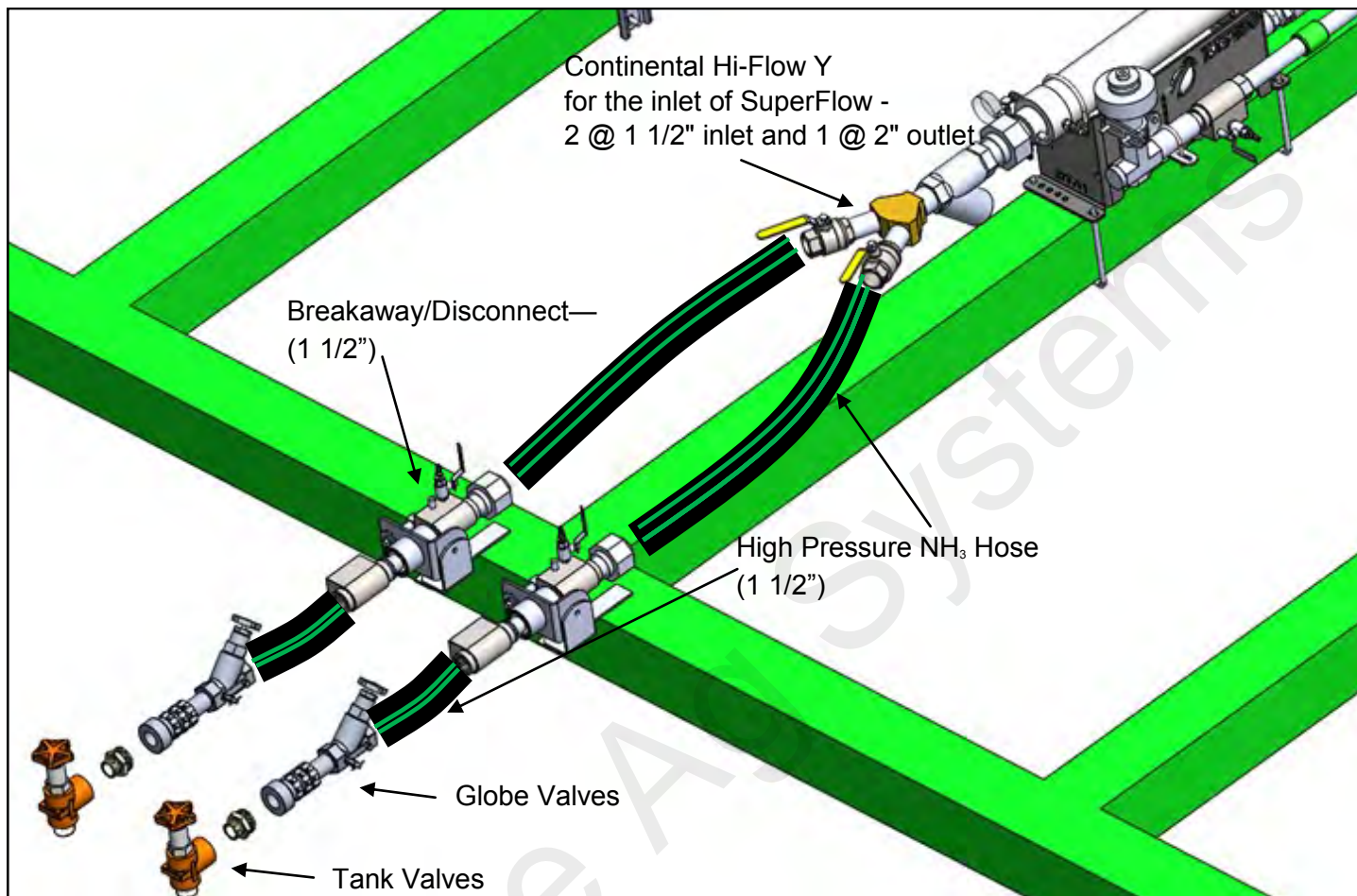

Installation and Setup Instruction Tags-See the manual and accompanying literature for more information.

DUMP ORIFICE HOSE BARB

To minimize the amount of ammonia going out the dump lines use the chart to determine the hose barb size to use.

1-12 GPM	13-18 GPM	19-26 GPM	27-33 GPM	34-Up GPM
A	B	C	D	E

$$\text{Tool bar width in feet} \times \text{Speed} \times \text{Actual lbs N per acre} \times 0.1212$$

$$/ 0.82 / 5.14 / 60 = \text{GPM}$$

PN 398-10-2807Y1

DUMP OUTLET HOSE BARBS (2)

Connect an appropriate length of 3/4" hose from each dump outlet hose barb to the 2 vapor knives on the applicator. Fasten each end with a worm gear clamp.

PN 398-10-2808Y1

Some applicators already have the vapor knives attached. If not, use the ones in the kit.

PN 398-10-2808Y1

Installation Instructions A-360SP Splitter

Correct Orifices Must Be Installed Before Use.

See orifice chart on back side of this tag.

See the instruction sheet and manual for details.

PN 398-10-2811Y1

Pressure	100 PSI	50 PSI	Orifice
Flow Per Outlet	Up to 7 GPM	Up to 5 GPM	.302
	5 to 12 GPM	4 to 9 GPM	.437

A-360SP Splitter Orifices

$$\#NH_3 \text{ per acre} \times \text{speed} \times \text{tool bar width in feet} \times .1212 \div 5.14 \div 60 \div \text{number of manifolds} = \text{GPM per outlet}$$

Or

$$\#N \text{ per acre} \times \text{speed} \times \text{tool bar width in feet} \times 0.1212 \div 0.82 \div 5.14 \div 60 \div \text{number of manifolds} = \text{GPM per outlet}$$

Bleeder Valve Installation Instructions

Connect hose and run hose to a safe location to bleed ammonia vapor.

PN 398-10-2810Y1

Bleeder Valve Safety

USE INSTRUCTIONS

This may not be the only place you have to bleed. Be certain entire system has been bled before working on system.

Be certain it is **safe** to bleed the system.

Open valve **SLOWLY** when bleeding system.

PN 398-10-2810Y1



Continental Tank Valves

153-

1406-G High Flow
1 1/4" MPT Tank Connector x 1 1/2" FPT Outlet
45 GPM



1809-BFV High Flow
1 1/2" MPT Tank Connector x 1 1/2" FPT Outlet
60 GPM



Depending on the rates, speeds, and tank pressure (temperature), a system may need to be connected to tanks with High Flow tank valves in order to allow enough product flow. The entire plumbing arrangement (valves, hoses, connections) must have high flow capacity in order to maximize flow to reach high rates at high speeds and cold temperatures.

Safety Reminder

Always bleed all segments of the system before working on or around the system.

NH₃ Inlet Plumbing Kit from Nurse Tank to Breakaway 158-00-

This kit includes: 1 1/4" or 1 1/2" High Pressure hose and one of the following Globe Valve Assemblies

Globe Valve Assembly 153-

A-215-L

1 1/4" Globe valve x 1 3/4" Female Acme Fitting
Long with bleeder valve



A-216-L

1 1/4" Globe valve x 2 1/4" Female Acme Fitting
Long with bleeder valve

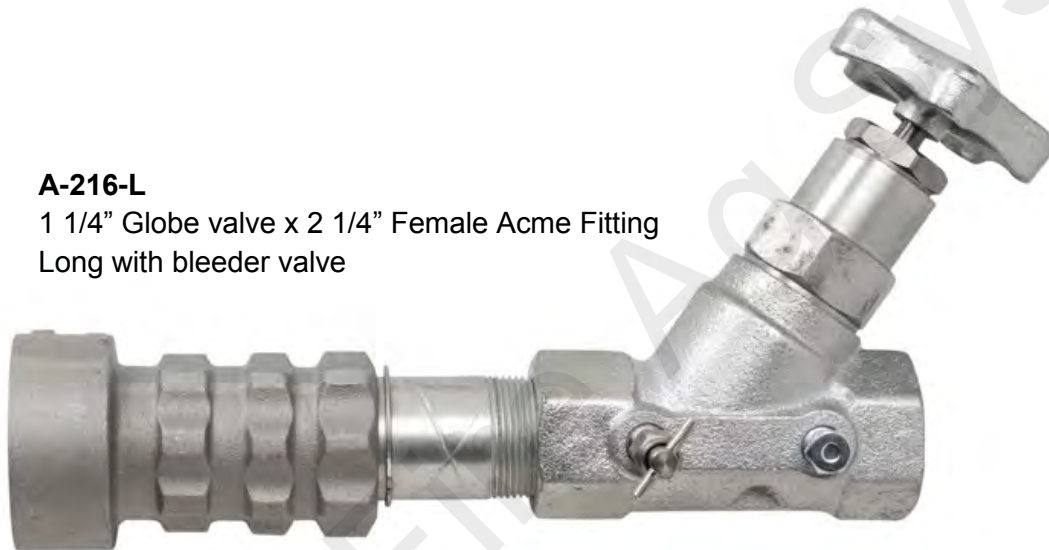

A-217-L

1 1/2" Globe valve x 2 1/4" Female Acme Fitting
Long with bleeder valve



Torpedo Kit 159-00— Kit includes Breakaway, High Pressure NH₃ Hose and SuperFlow NH₃ Assembly

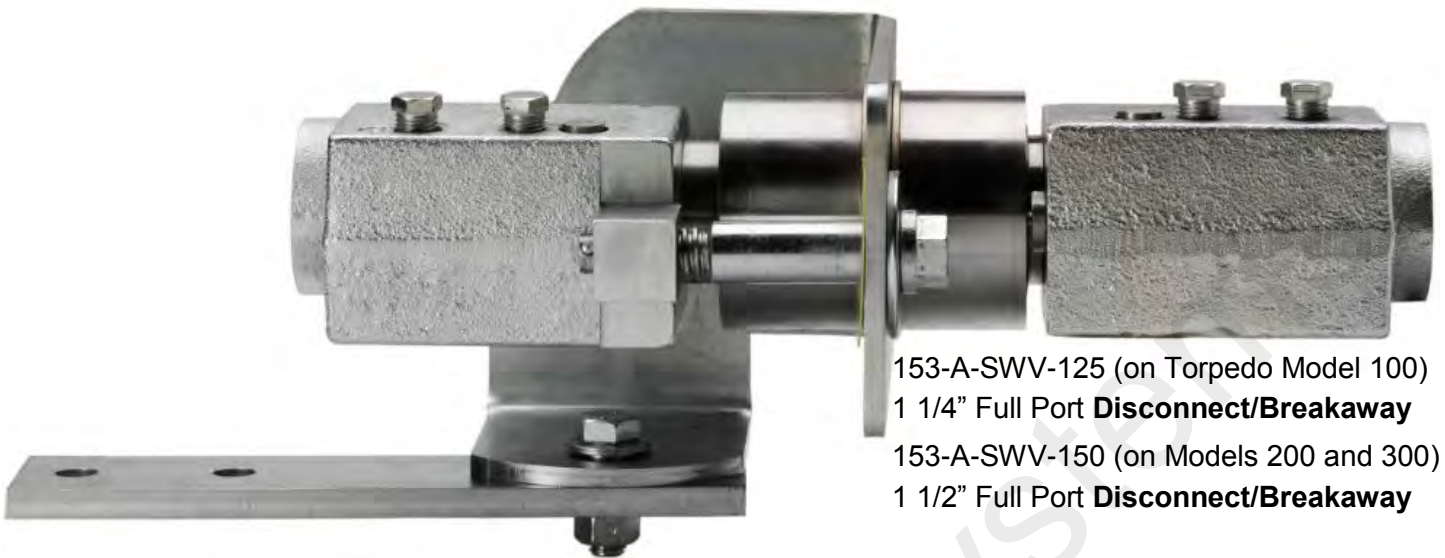

153-A-SWV-125 (on Torpedo Model 100)
1 1/4" Full Port **Disconnect/Breakaway**
153-A-SWV-150 (on Models 200 and 300)
1 1/2" Full Port **Disconnect/Breakaway**

- Full port 1 1/4" (or 1 1/2") through-holes
- Practically no pressure drop
- Swing valve style checks that swing out of the flow for superior flow characteristics
- All Stainless Steel, except housing, prevents rust and corrosion
- Built-in reconnection and disconnection acme bolt
- Dual 1/4" pipe ports on each side for bleeder valves and hydrostats
- 35% larger than other units
- **Read the complete installation and operating instructions that come with Disconnect/Breakaway**

153-A-1000 1/4" MPT x 1/4" FPT NH₃ **Needle Valve**--
can attach pressure gauge or transducer here

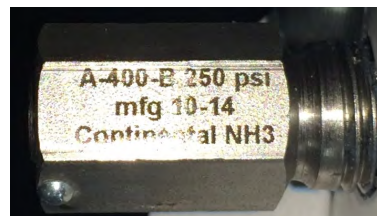
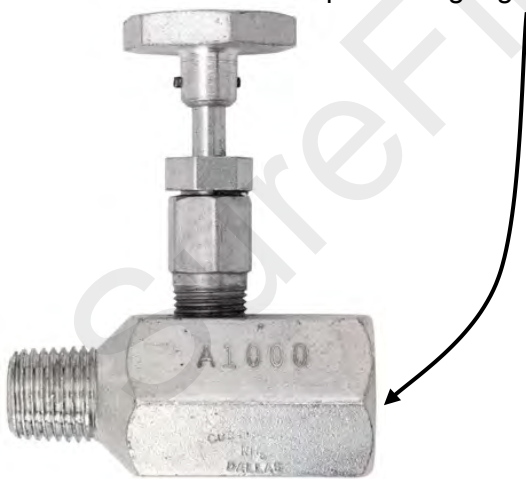

End view

153-A-400-B 1/4" **Hydrostat Relief Valve**—250 PSI—(Keep the black cap on)
Used in various segments of the system as a safety relief valve. This component has a **MFG Date** stamped on it. Replace within 5 years.

Safety Reminder

Wear tight-fitting non-vented goggles when working around anhydrous ammonia.

Torpedo™ SuperFlow NH₃ Assembly 202-2693Y1

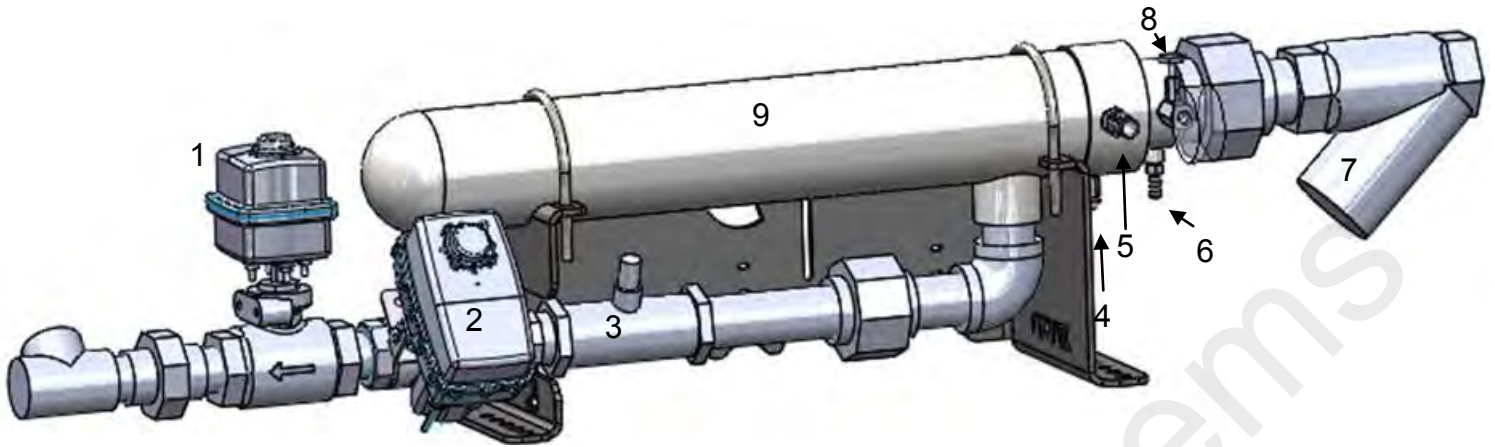

1	202-2691Y1	SureFire 1 1/4" NH ₃ Servo Valve —7 sec. 118 degree open/close -
2	202-KZ67GY	1 1/4" SS KZ NH ₃ shut-off valve with 3-pin WP shroud
3	204-02-2692Y1	Raven SS RFM 60S Flowmeter 1 to 60 GPM with 3-pin MP 150 shroud
4	153-A-411	1/4" Bleeder valve
5	151-050075	1/2" MPT X 3/4" Hose Barb—Dump Outlet Hose Barb (plumb to Dump Knife)
6	151-025038	1/4" MPT X 3/8" Hose Barb—3/8" product feedback hose attaches here
7	762-A1SC-2	2" Y filter
8	153-A-1000	1/4" MPT x 1/4" FPT NH ₃ Needle Valve --can attach pressure gauge
9	762-A-SF-	Continental SuperFlow Exchanger and vapor tubes/ etc.
10	153-A-400-B	1/4" Hydrostat Relief Valve —250 PSI—(Keep the dust cap on)

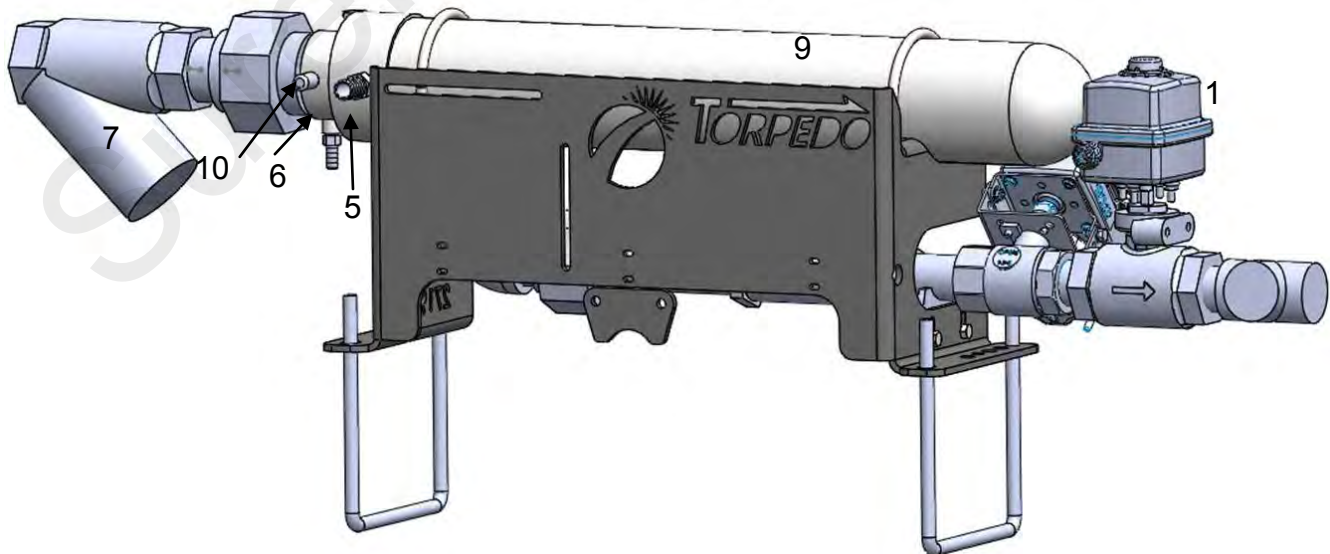

SureFire Torpedo NH3

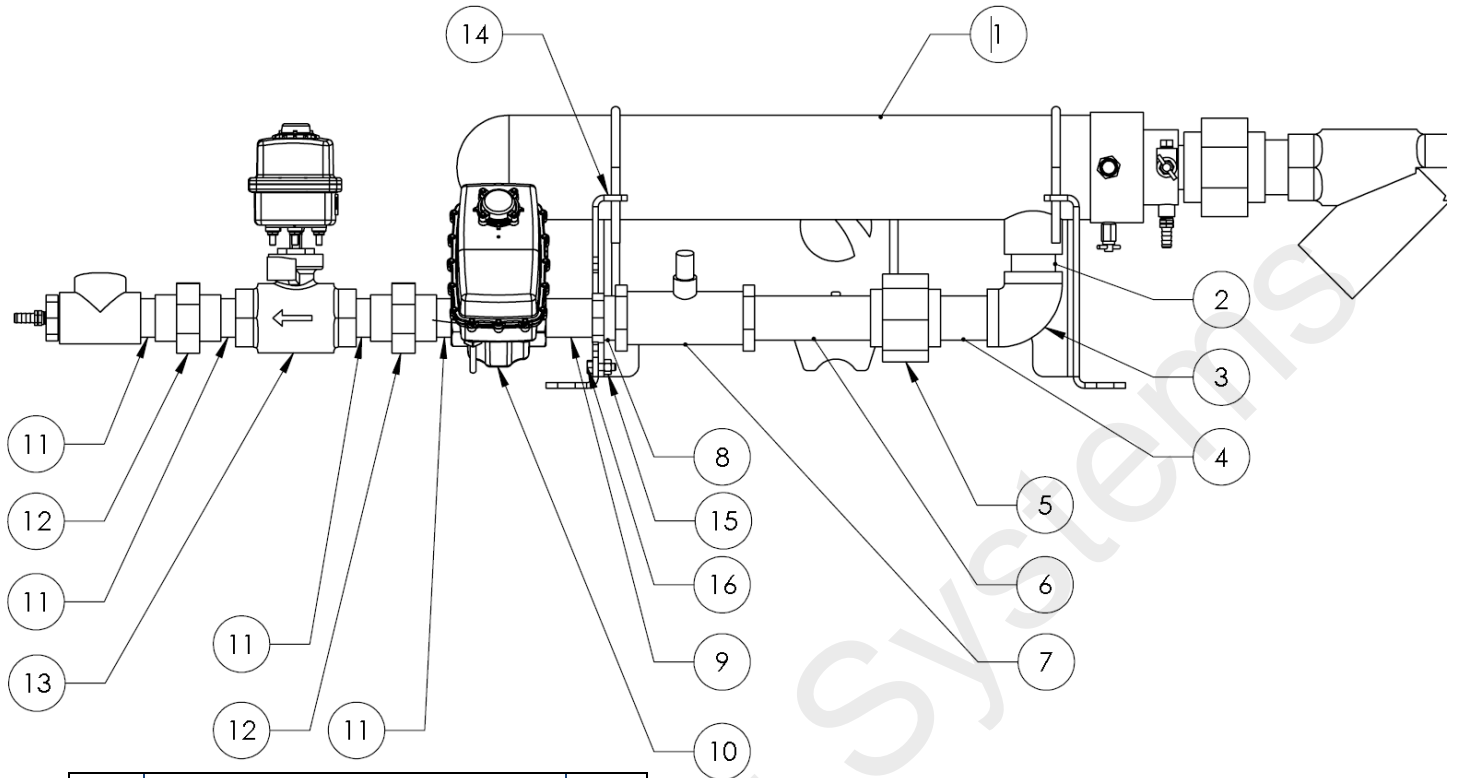

Item	Description	Qty
1	Heat Exchanger	1
2	Nipple	1
3	Elbow	1
4	Nipple	1
5	Union	1
6	Nipple	1
7	Flowmeter	1
8	Reducer Bushing	1
9	Nipple	1
10	On/Off Valve	1
11	Nipple	4
12	Union	2
13	Control Valve	1
14	Heat Exchanger Base	1
15	5/16" Flange Nut	2
16	5/16" x 1" HCS G5	2
18	Nipple	1
19	Tee	1
20	1/4" Plug	1

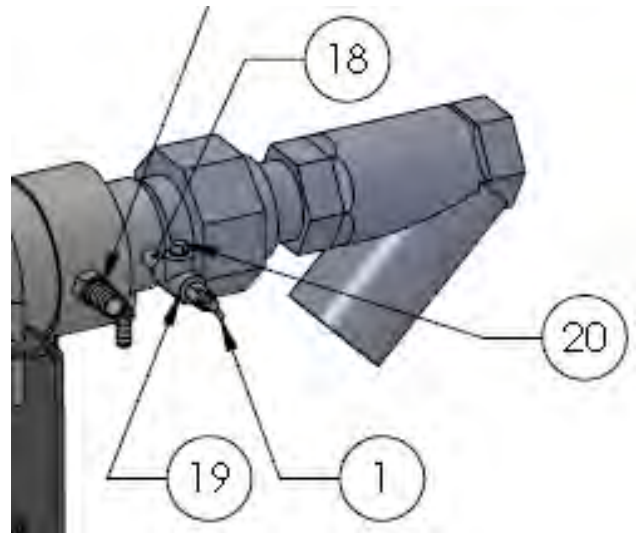

Torpedo™ SuperFlow NH₃ Assembly 202-2693Y1

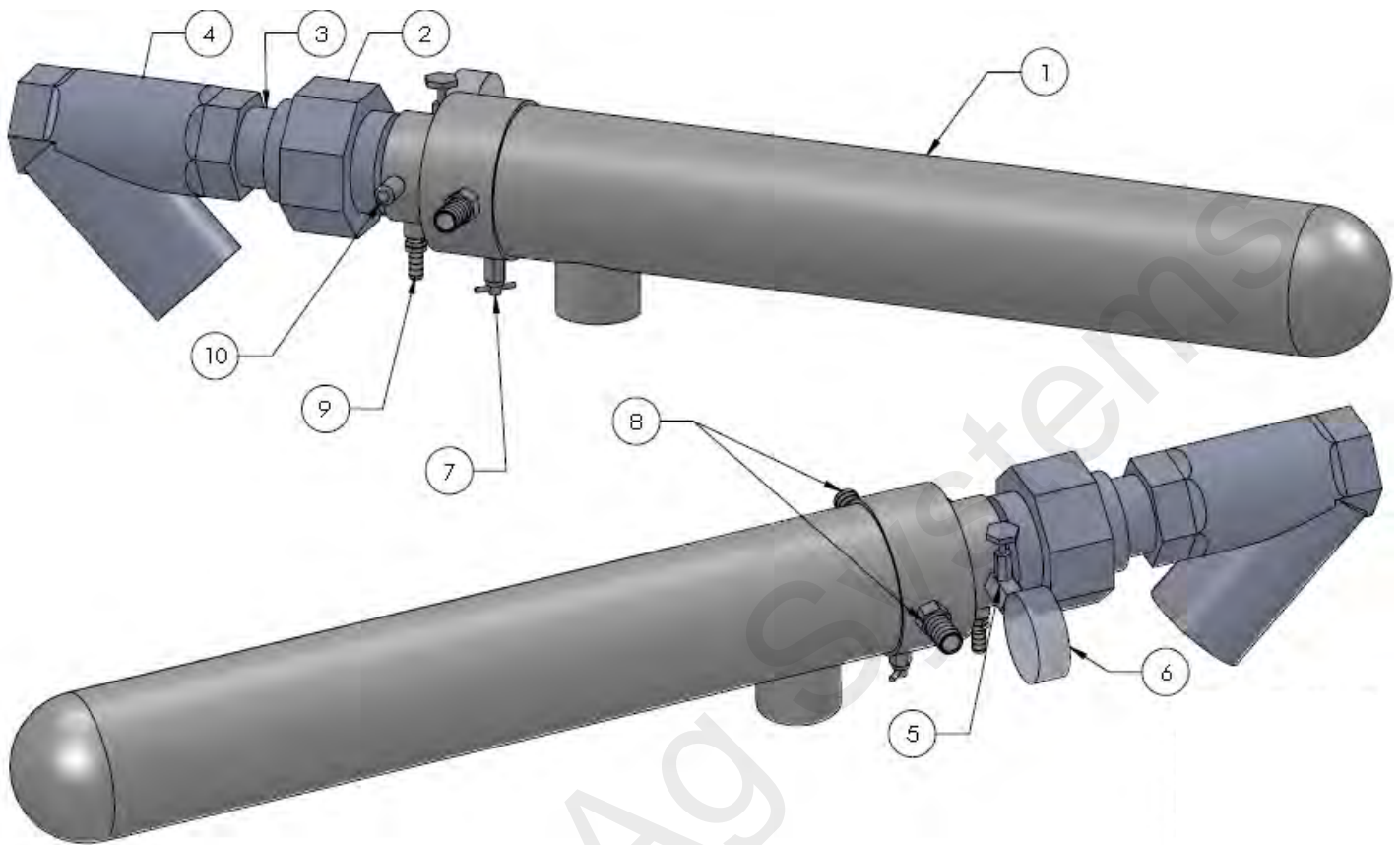

Item No.	Part Number	Description	QTY
1	153-A-SF-3000GH-2	2" Exchanger	1
2	150-200UN-S80	2" Union-Schedule 80	1
3	150-200NIP-SH-S80	2" X SH Nipple-Schedule 80	1
4	762-A1SC-2	2" Y Filter	1
5	153-A-1000	1/4" MPT X 1/4" FPT NH3 Needle Valve	1
6	137-ASG400	Pressure Gauge (Optional)	1
7	153-A-411	1/4" Bleeder Valve-Continental	1
8	151-050075	1/2" MPT X 3/4" Hose Barb	2
9	151-025038	1/4" MPT X 3/8" Hose Barb	1
10	153-A-400-B	1/4" Relief Valve-250 PSI	1

Splitter Options-mounted to Torpedo or mounted remotely

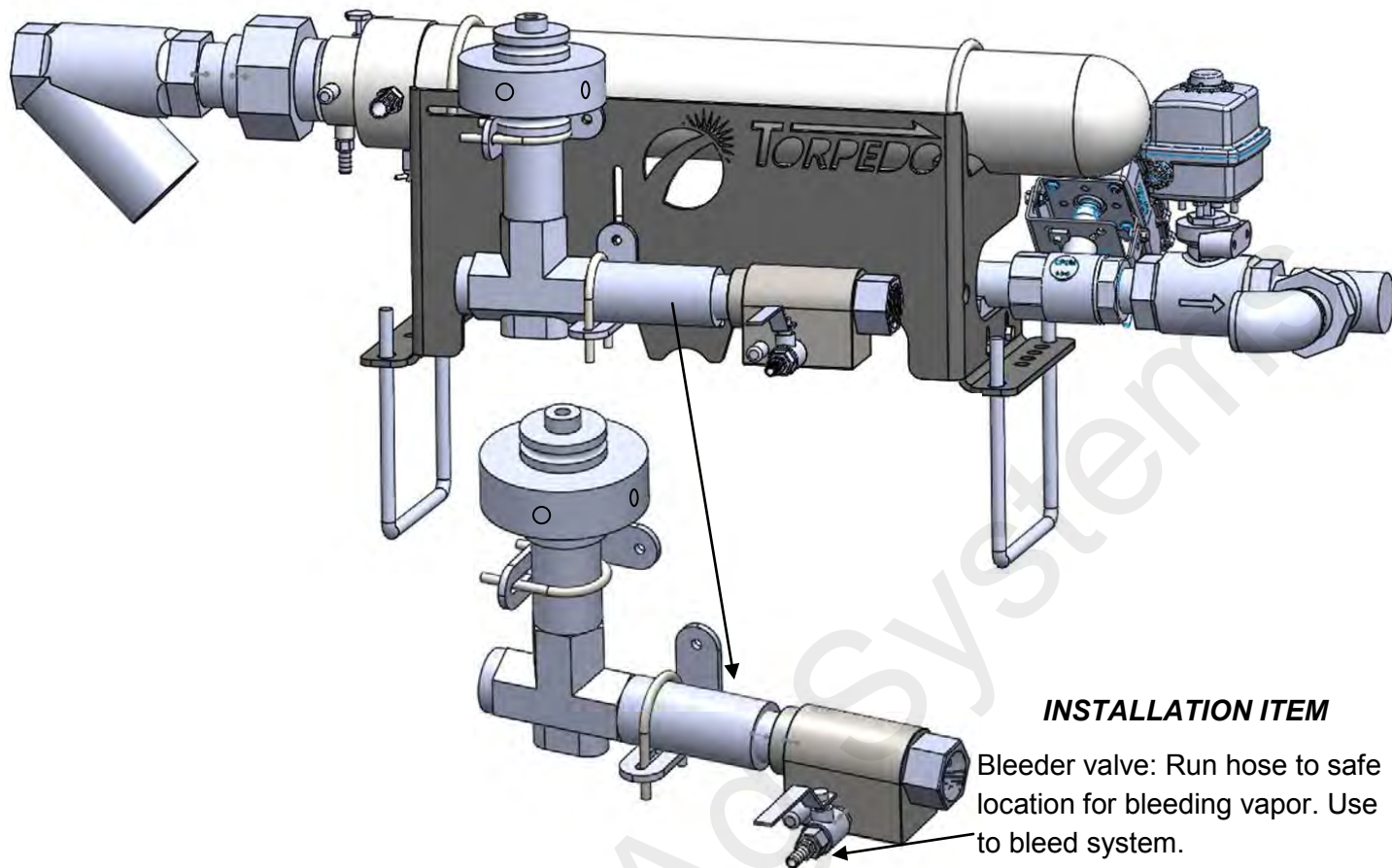

INSTALLATION ITEM

Bleeder valve: Run hose to safe location for bleeding vapor. Use to bleed system.

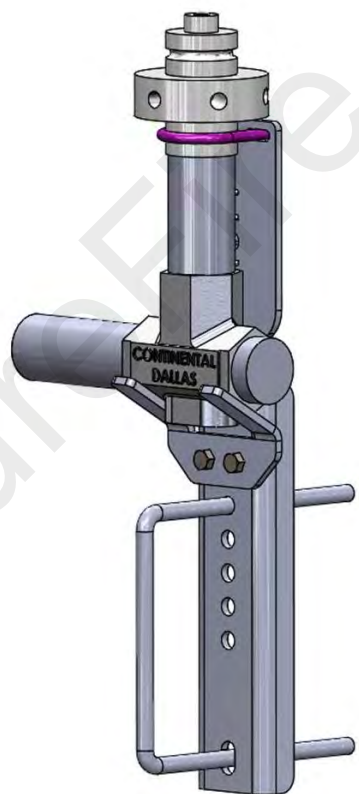

A-360 Splitter Remote Mount

If the splitter is mounted remotely from the Torpedo, you will need an appropriate length of 1 1/4" high pressure hose from the Torpedo to the splitter if using electric section valves or 1" EVA hose if not using electric section valves.

Safety Reminder

Check all hoses and fittings and immediately replace any that show signs of wear or are out of date.

A-360 Bracket Kit 159-11-100500

Manifolds and Splitters



A-360 Manifold

A-360-MA-(W,C,or J)- *Medium, Large, or Jumbo*

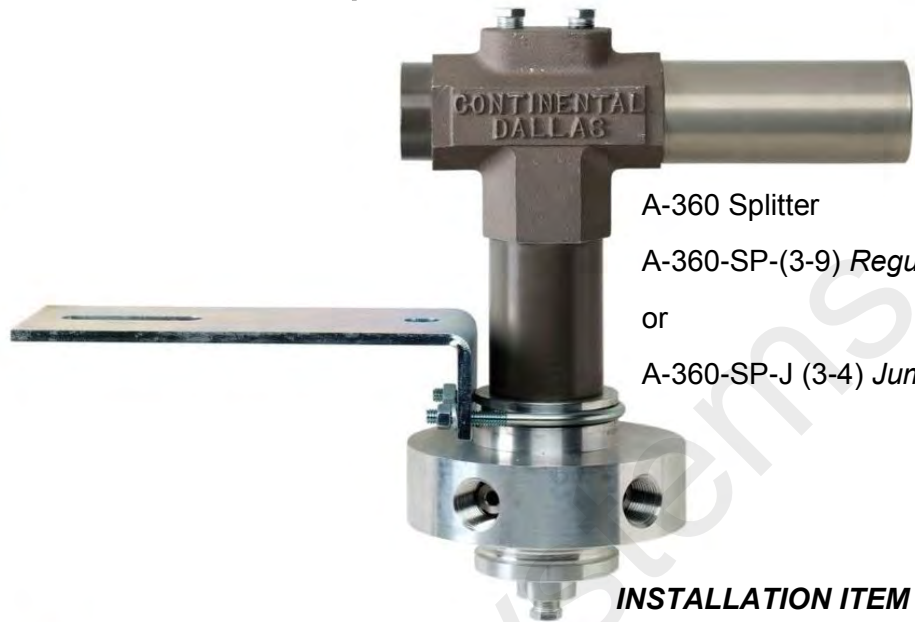

A-360 Splitter

A-360-SP-(3-9) *Regular*

or

A-360-SP-J (3-4) *Jumbo*

INSTALLATION ITEM

Must install correct orifices in Splitter during installation. See the next page or see the instructions with the Splitter.

Features of A-360 Manifolds and Splitters

Patented step down injector technology mixes and accelerates the ammonia into an upper chamber, the tee, and the lower manifold chamber. These features mix the vapor and liquid so each outlet gets an equal amount of both.

- As close as 1 to 3 percent row-to-row variation
- Includes SS hose barbs on manifolds (Half-rate orifice hose barbs are available for half-rate end-rows)
- Manifold outlets available from 3 to 16 for medium (W), 3 to 13 for large (C), and 3 to 10 for jumbo (J)
- Splitter outlets available from 3 to 9 outlets (3 or 4 outlets on Jumbo)
- Pressure gauge port on both manifolds and splitters
- Can be mounted upside down

Splitter Selection

NH₃
GPM per outlet

100 PSI tank	50 PSI tank	Model Number
Up to 12 GPM	Up to 9 GPM	A-360SP
12 to 25 GPM	9 to 18 GPM	A-360SP-J

To determine your GPM per outlet use one of the following formulas

#NH₃ per acre **X** speed **X** tool bar width in feet **X** .1212 ÷ 5.14 ÷ 60 ÷ number of manifolds = **GPM per outlet**

Gallons per minute ÷ number of manifolds = **GPM per outlet**

#N per acre **X** speed **X** tool bar width in feet **X** 0.1212 ÷ 0.82 ÷ 5.14 ÷ 60 ÷ number of manifolds = **GPM per outlet**

A-360SP Splitter

The splitter was designed to have stainless steel threaded orifices on the outlet ports of the manifold. See picture below.

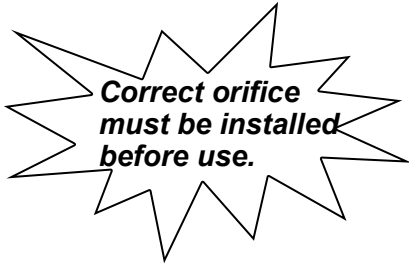

Threaded orifice not installed

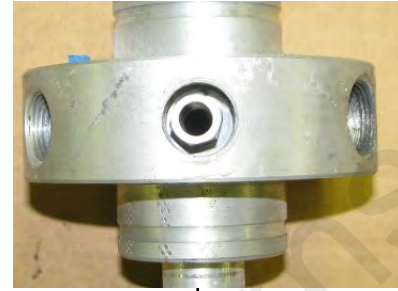

Threaded orifice installed

Use a 5/8" socket wrench to install or remove them when necessary. See picture below.



These orifices can be swapped out for different sizes depending on your application needs. Select the correct orifice based on your application needs by referring to the chart below.



NH3 GPM per outlet 100 psi tank	GPM per outlet 50 psi tank	Orifice
Up to 7 GPM	Up to 5 GPM	.302
5 to 12 GPM	4 to 9 GPM	.437
12 to 25 GPM	9 to 18 GPM	JUMBO

To determine your GPM per outlet use one of the following formulas

#NH3 per acre **X** speed **X** tool bar width in feet **X** .1212 ÷ 5.14 ÷ 60 ÷ number of manifolds = **GPM per outlet**

Gallons per minute ÷ number of manifolds = **GPM per outlet**

#N per acre **X** speed **X** tool bar width in feet **X** .1212 ÷ .82 ÷ 5.14 ÷ 60 ÷ number of manifolds = **GPM per outlet**

As a general guideline, manifold pressures greater than 2/3 of tank pressure may restrict total system flow. Manifold pressures less than 30 PSI may result in increased row-to-row variation. Manifold pressures will change as rate, speed, and tank pressure (temperature) change.

A-360 Manifold



Manifold Selection

To choose the correct manifold, use one of the formulas below to determine your lbs NH₃ per outlet (per hour) and look on the chart to see which is the correct manifold for that application range.

NH₃
Lbs/hr
per outlet

100 PSI tank 64° F	50 PSI tank 34° F	Model Number
Up to 170# NH ₃	Up to 127# NH ₃	A-360MA-W
170-422# NH ₃	127-316# NH ₃	A-360MA-C
Above 422# NH ₃	Above 316# NH ₃	A-360MA-J

To determine your NH₃ per outlet use one of the following formulas:

(#NH₃ per acre X speed X tool bar width in feet X 0.1212 ÷ total number of outlets on the bar = **NH₃ per outlet**)

(Gallons per minute X 5.14 X 60 ÷ total number of outlets on the bar = **NH₃ per outlet**)

(#N per acre X speed X tool bar width in feet X 0.1212 ÷ 0.82 ÷ total number of outlets on the bar = **NH₃ per outlet**)

Note: All manifolds must be within one outlet of each other. For example, if you have 17 rows split into 3 sections, your manifolds must have 6, 6, and 5 outlets. You cannot have 5, 5, and 7.

As a general guideline, manifold pressures greater than 2/3 of tank pressure may restrict total system flow. Manifold pressures less than 30 PSI may result in increased row-to-row variation. Manifold pressures will change as rate, speed, and tank pressure (temperature) change.

Nitrogen stabilizers, such as N-serve, added to the ammonia may corrode aluminum and may also leave crystal-like deposits which could eventually clog up the orifices. To avoid problems, disassemble and thoroughly clean the manifolds at the end of each application season.

See the complete Continental NH₃ Products *Installation, Operation, Repair and Maintenance Instructions* that came with the splitter and manifold for further tips and information.

Optional Vertical Dam Manifold

Continental Vertical Dam Manifold

Each manifold has 16 of 3/8" HB outlets

NH₃
Lbs/hr
per outlet

100 PSI tank 64° F	50 PSI tank 34° F	Model Number
24-183	18-137	152-A-MVD-16A120
Above 183	Above 137	152-A-MVD-16A201

See the formulas on the previous page to calculate the NH₃ lbs/hr per outlet.

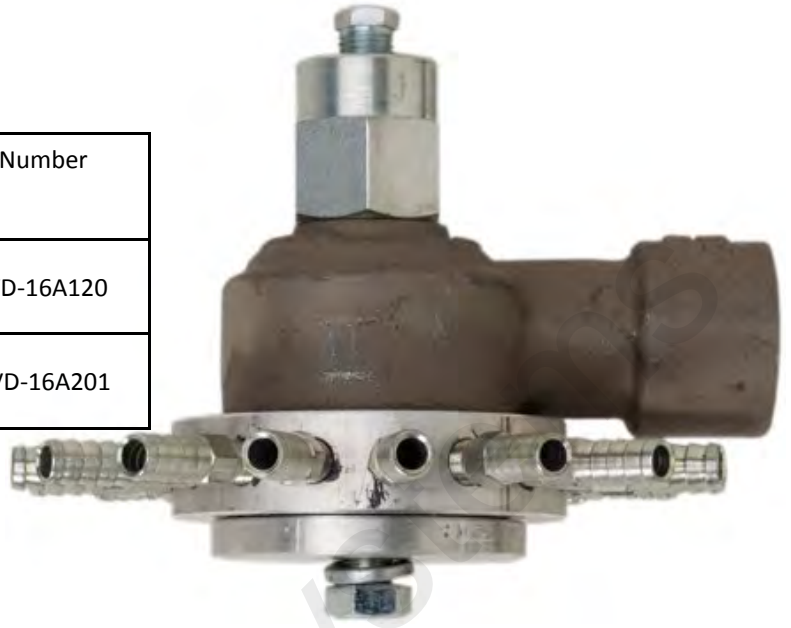

Features of A-MVD Vertical Dam Manifold

- Get within 6 to 8% row-to-row accuracy
- Better accuracy than traditional manifold
- Plug outlets you don't need
- Half-rate orifice hose barbs are available if needed for half-rate end rows

As a general guideline, manifold pressures greater than 2/3 of tank pressure may restrict total system flow. Manifold pressures less than 30 PSI may result in increased row-to-row variation. Manifold pressures will change as rate, speed, and tank pressure (temperature) change.

MVD Bracket Kit
159-11-200500

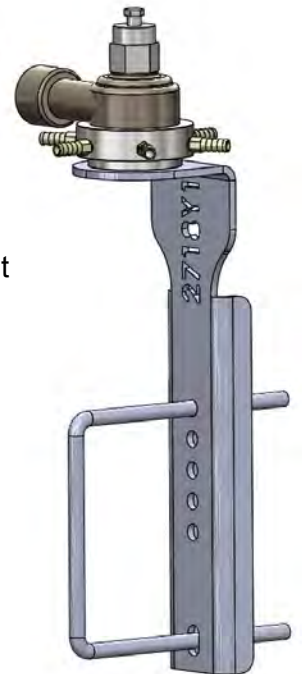

BE CAREFUL OUT THERE!

INSTALLATION ITEM

Dump Hose Barbs: Plumb 3/4" hose to vapor tube dump knives.

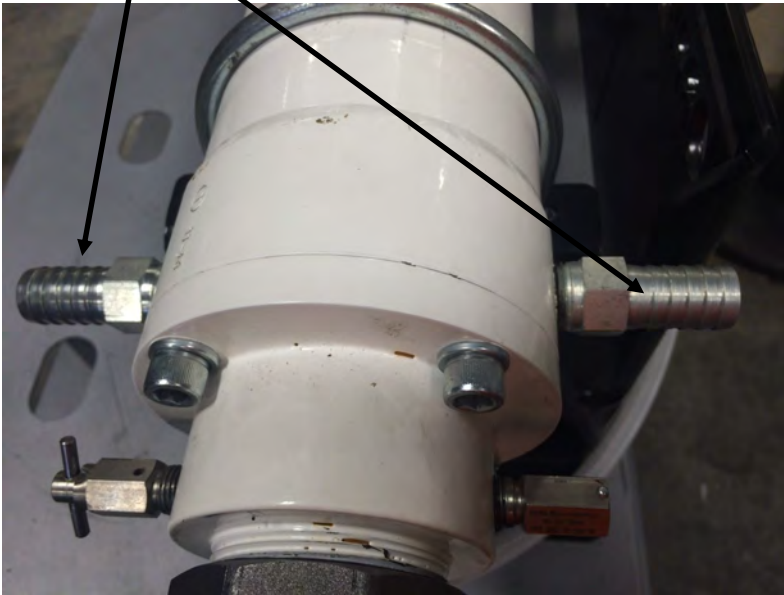

INSTALLATION ITEM

Dump Orifice Hose Barb: This controls the amount of ammonia that is used to cool the Exchanger. Using too small of an orifice may result in some vapor still being in the system when it goes through the flowmeter. Using too large an orifice will cause more ammonia than necessary to be dumped through the vapor tube dump knives. The letter indicating the orifice size is stamped on one of the hex sides.

GPM	1-12	13-18	19-26	27-33	34-UP
Orifice	A	B	C	D	E



INSTALLATION ITEM

Bleeder valve: Run hose to safe location for bleeding vapor. Use to bleed system.

Open valve slowly when bleeding system.

TORPEDO™



SureFire

Ag Systems



Flowmeter 204-02-2692Y1

Raven SS RFM 60S Flowmeter 1 to 60 GPM with 3-pin MP 150 shroud



The flowmeter calibration number is **72 pulses per gallon**.

Verify accuracy of flowmeter by comparing the Volume shown on the display with actual weigh tickets.

If the weigh ticket amount is more than shown on the display, LOWER the flow cal number.

Use the following formula to adjust the flow cal number:

$$(\text{Initial flow cal} \times \text{Volume shown on screen}) / \text{Weigh ticket amount} = \text{new flow cal}$$

See the next page for flowmeter parts, repair and maintenance.

RFM 60S Flowmeter

Item	Description	Raven Part #
1	Rotor / Magnet Assembly	063-0171-673
2	Hub / Bearing Assy, Upstream	063-0171-674
3	Hub Assembly, Downstream	063-0171-769
4	Ring, Retaining, Internal	335-0000-278
5	Stud Bearing	063-0173-062
6	Sensor Assembly	063-0171-669

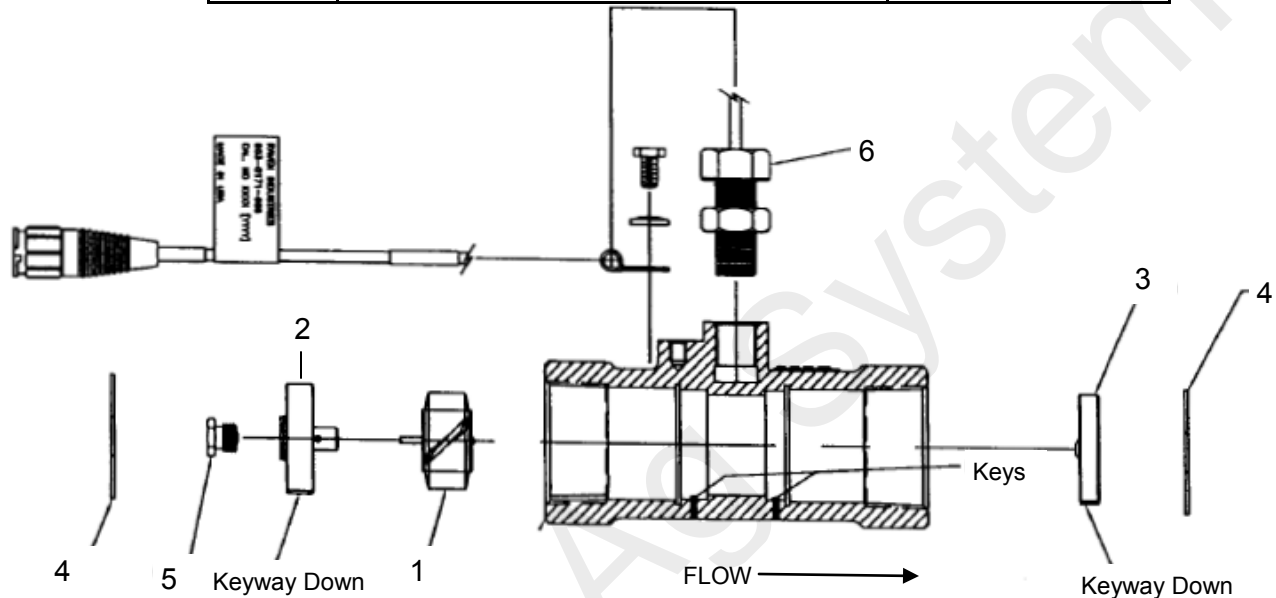

RFM 60S Flowmeter Maintenance and Adjustment Procedure

1. Be sure all NH₃ has been bled from the system before starting maintenance.
2. Remove flowmeter, brush away any debris and flush with clean water.
3. Remove the retaining rings carefully. Remove the bearing hub, turbine hub, and turbine from inside flowmeter housing.
4. Clean the turbine and hubs of metal filings and any other foreign material. Use pressurized air to blow metal filings out of both hubs and turbine. Confirm that the turbine blades are not worn. Hold turbine and bearing hub in your hand and spin turbine. It should spin freely with very little drag.
5. If bearing hub stud is adjusted or replaced, verify the turbine fit before reassembling. Put turbine hub and retaining ring in place. Put bearing hub with turbine against turbine hub inside the flowmeter housing. (Stud keys inside flowmeter housing must be lined up in the groove on the hub.) Put the retaining ring into the groove to lock bearing hub in place. Spin turbine by blowing on it. Tighten bearing hub until turbine stalls. Loosen the stud 1/3 of a turn. The turbine should spin freely.
6. Use a low pressure (5 PSI) jet of air through flowmeter in the direction of flow and again in the opposite direction to verify the turbine spins freely. If there is drag, loosen the stud on the bearing hub 1/16 turn until the turbine spins freely.
7. If turbine spins freely and the cables have checked out, but the flowmeter is not totalizing properly, verify that the sensor assembly is threaded all the way into the flowmeter body, and the orientation groove on top of the sensor is parallel with flowmeter body. If flowmeter still does not totalize, replace Sensor Assembly.

Electric Section Valves

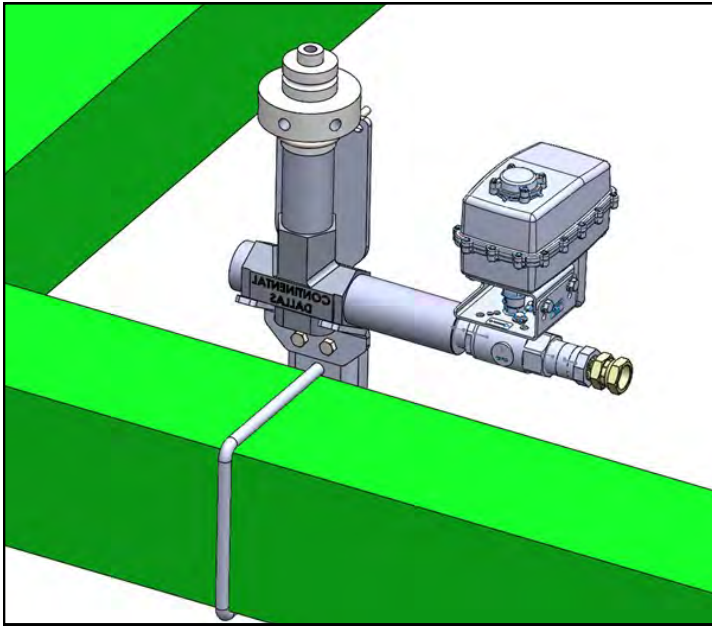

202-KZ67FY

1" SS KZ NH3 shut-off valve with 3-pin WP shroud

The valves have a 3-pin weather pack electrical connector. This has a power, ground, and switched wire. The power measured to ground should have 12 volts when the controller is on. The switched wire will have 12 volts to turn the valve on, and 0 volts to turn the valve off.

Wiring Connector:

Pin A—Red, 12 Volts +

Pin B—Black, Ground -

Pin C—White, Signal

12V=on ; 0V=off

Pressure gauges and sensors

137-ASG60 2 1/2" Silicone Filled Stainless Gauge-60 PSI
For manifolds (optional)

137-ASG400 2 1/2" Silicone Filled Stainless Gauge-400 PSI
For Torpedo SuperCooler (optional)

Or

521-05-050400 NH3 400 PSI 3-wire pressure sensor (0-5 V DC
12.5 mv/PSI) with 3-pin 150 MP Tower
For Torpedo SuperCooler (optional)

159-10-200200 SuperCooler Splitter Kit for 2 manifolds (NO ELECTRIC SECTIONS)

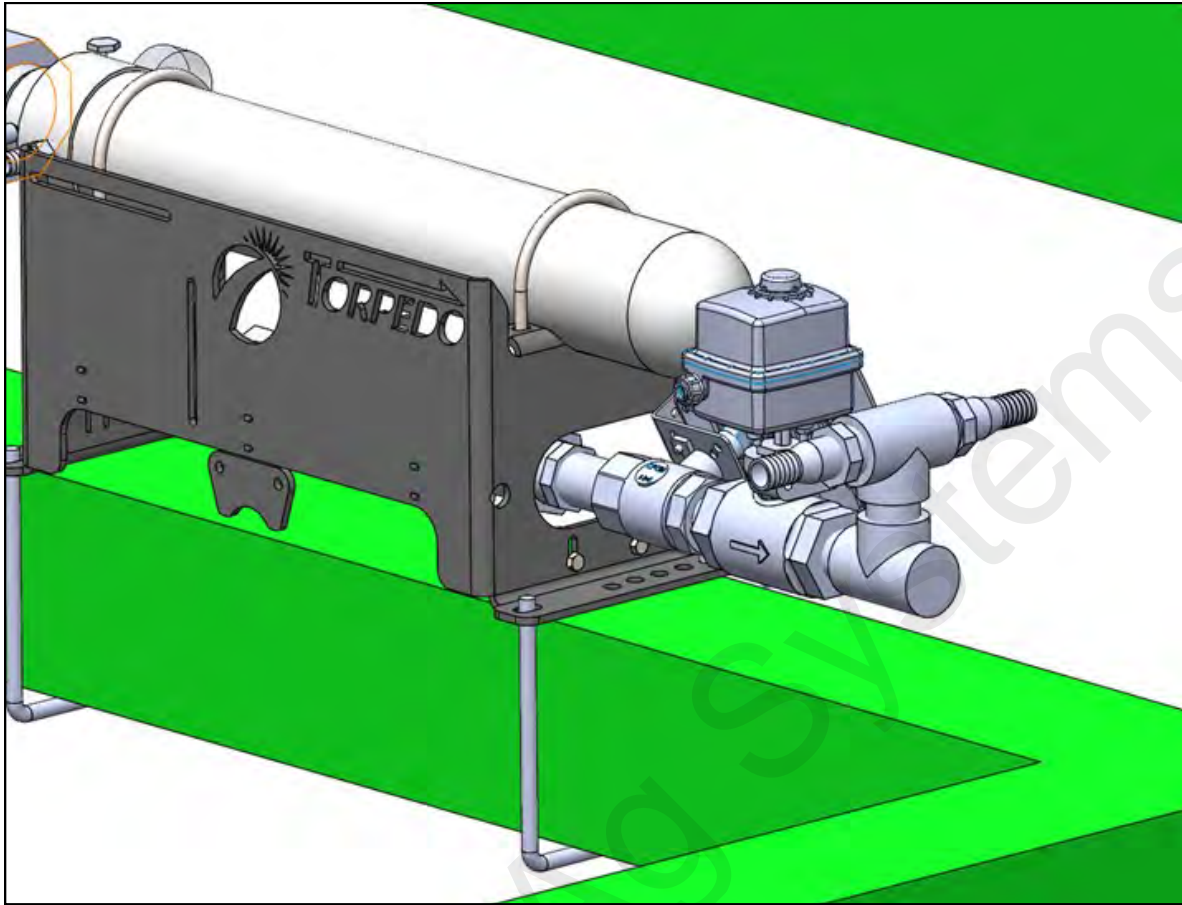

To split the flow to 2 manifolds a Tee is used. If going to 2 manifolds with no electric section valves 1" reinforced EVA hose is used (equal length to each manifold).

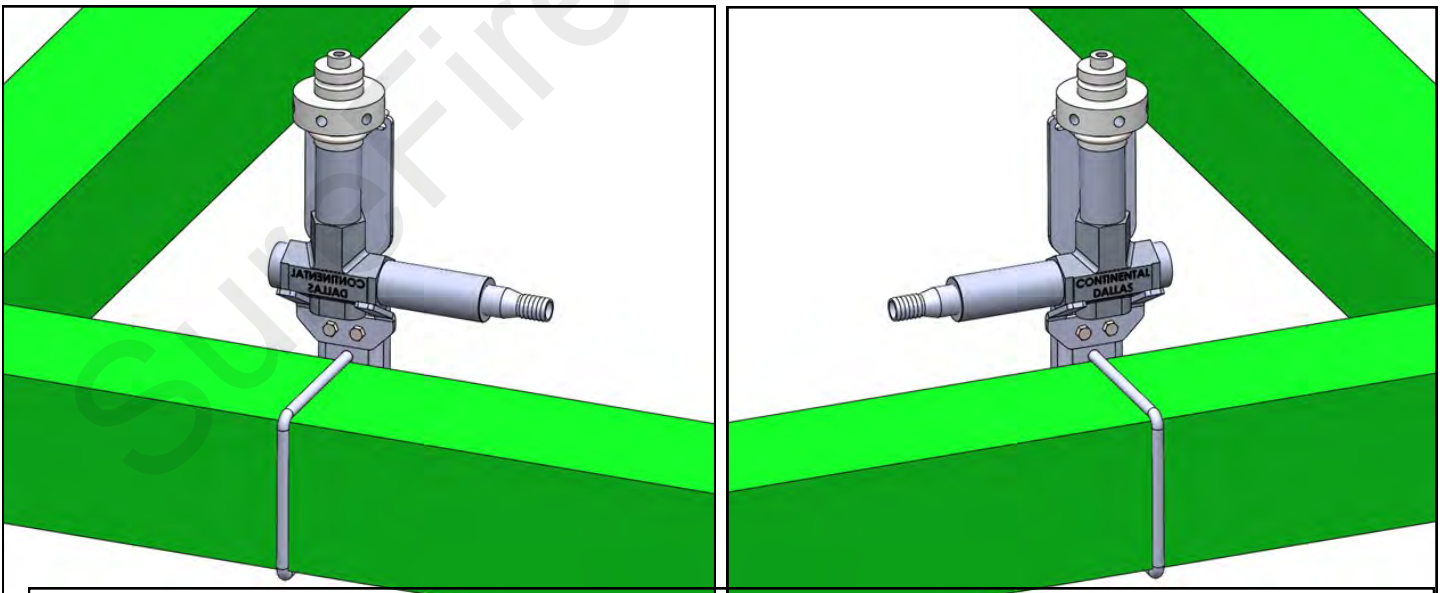

Safety Reminder

Flush with water for at least 15 minutes if exposed to anhydrous ammonia.

Electric Valve Kits for doing multiple sections

When using electric section valves, you must use high pressure hose from the Splitter to the section manifolds. These hoses must be the same length. Recommended hose is 1" high pressure hose for 3 sections or less and 3/4" high pressure hose for 4 or more sections.

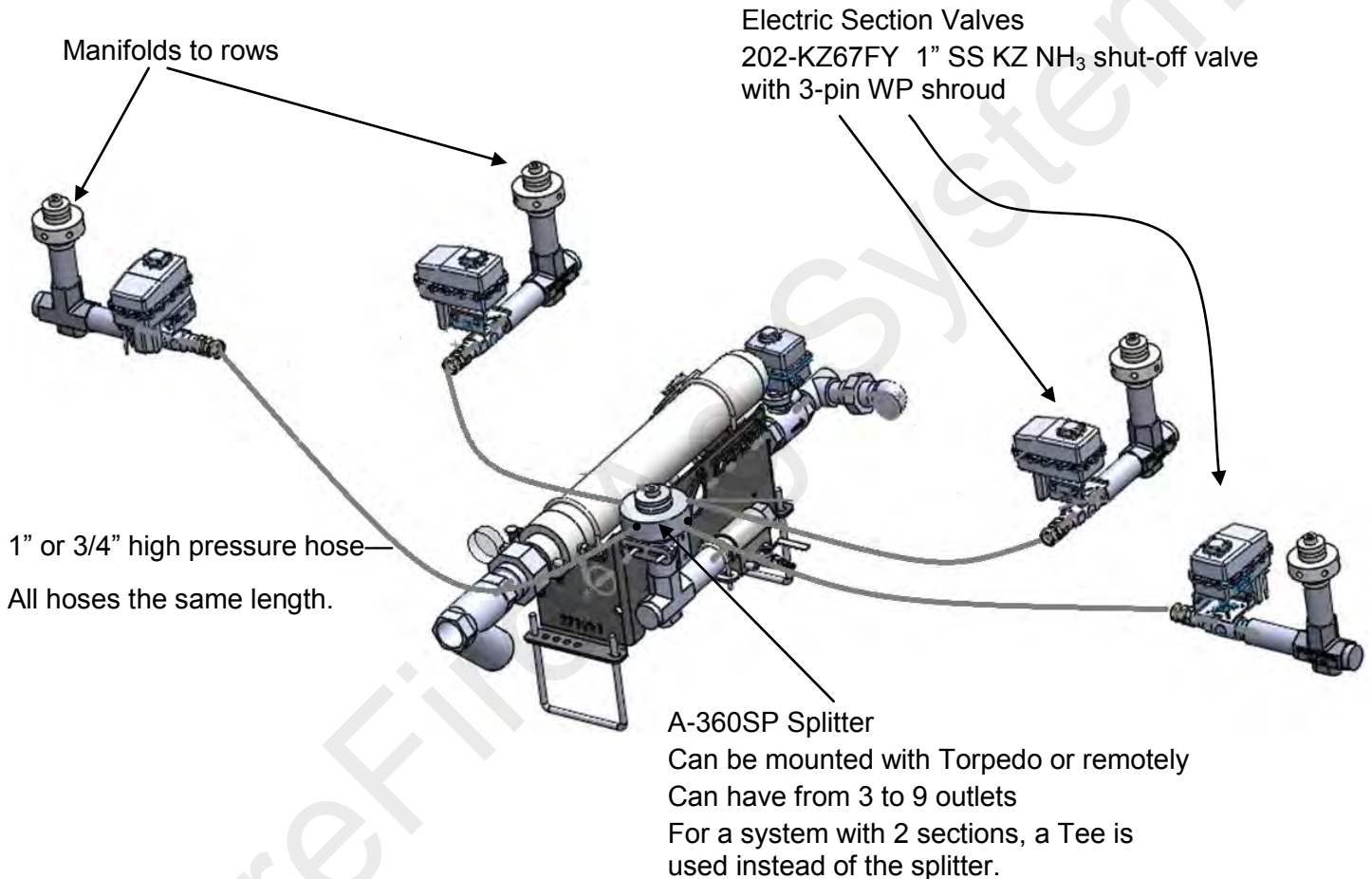

Safety Reminder

Make sure the nurse tank has 5 gallons of fresh clean water.

159-10-100200 SuperCooler Splitter Kit for 2 ELECTRIC SECTIONS

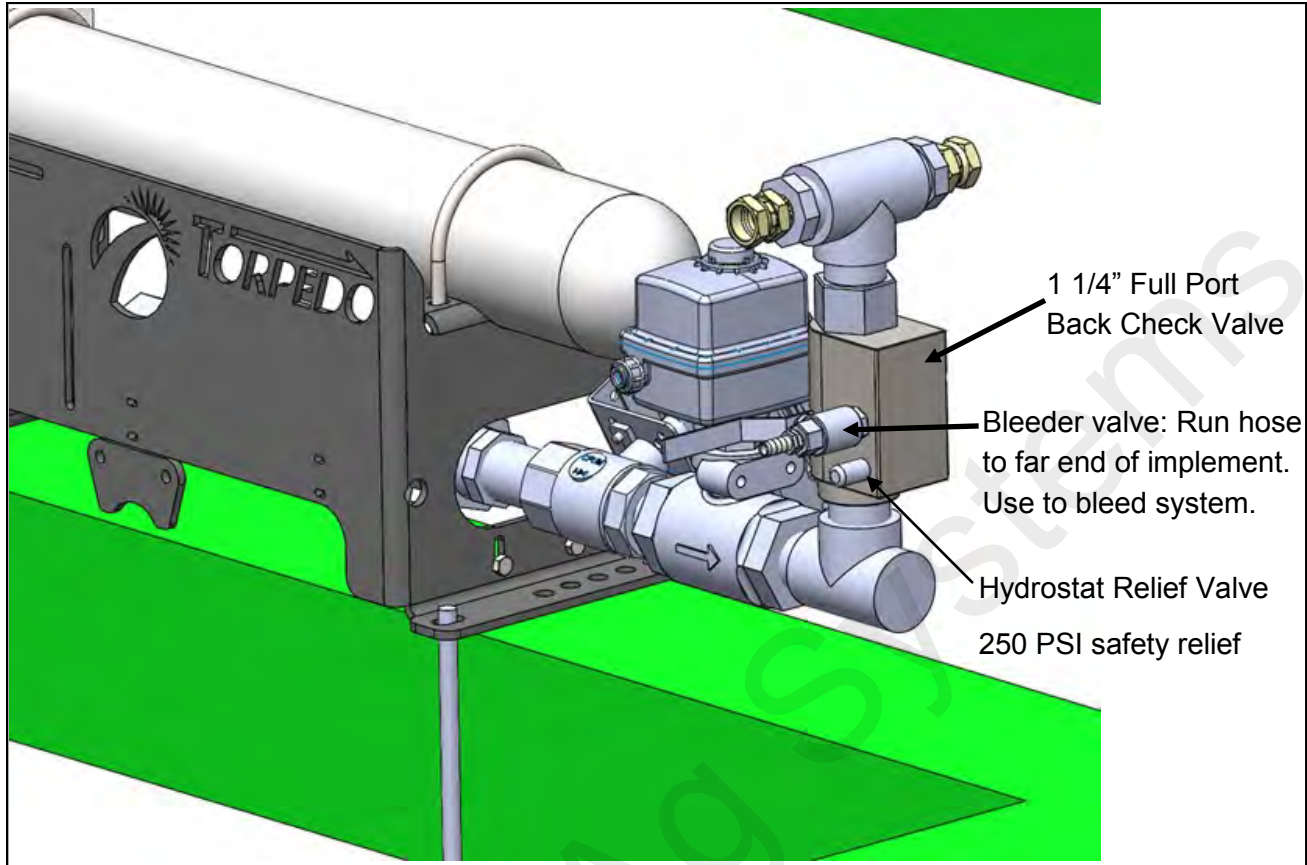

To split the flow to 2 manifolds a Tee is used. If going to 2 manifolds with electric section valves 1" high pressure hose is used (equal length to each manifold).

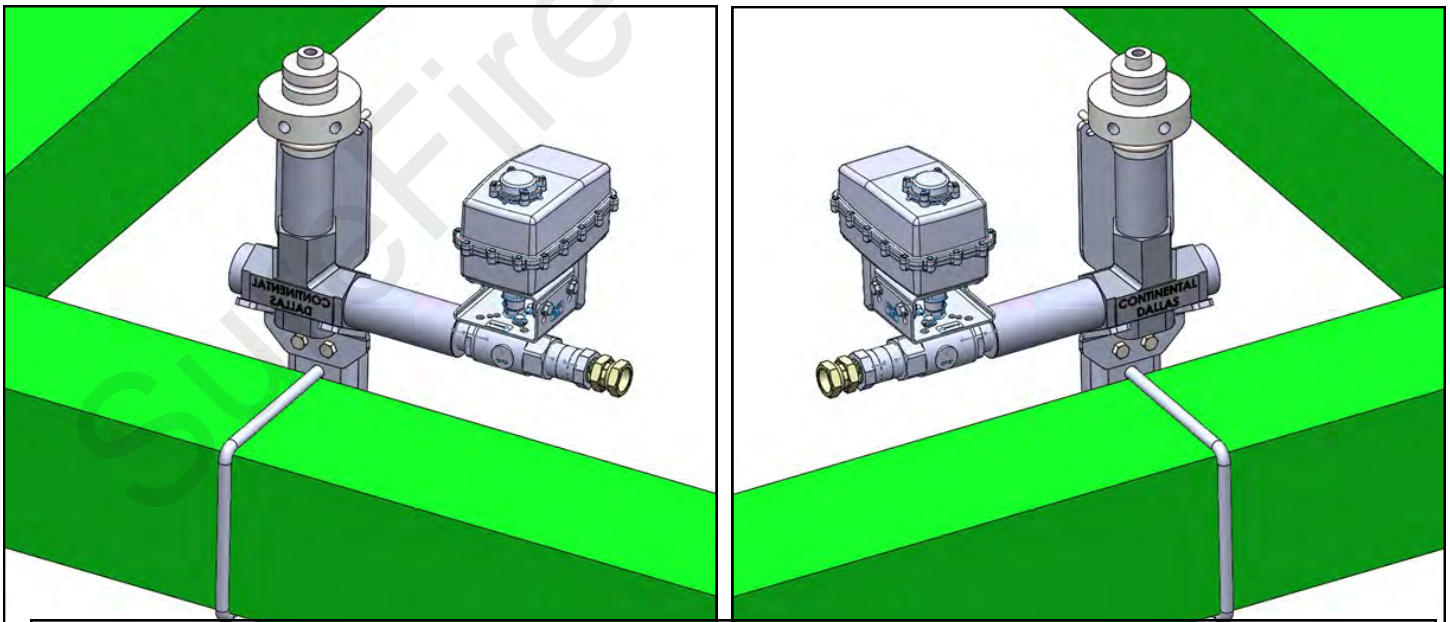

Safety Reminder

Always know the wind direction and park in an appropriate direction when servicing the system or changing tanks. The wind is your friend.

Gauge Tree Assembly (Optional)

159-11-500500 Black Gauge Tree Kit for 1-4 gauges with 7x7 u-bolt

159-11-500600 Black Add-on Gauge Tree Kit for 5-8 gauges w/ mounting hardware
(Gauges not included)

Use 137-ASG60 2 1/2" Silicone Filled Stainless Gauge-60 PSI-one per manifold

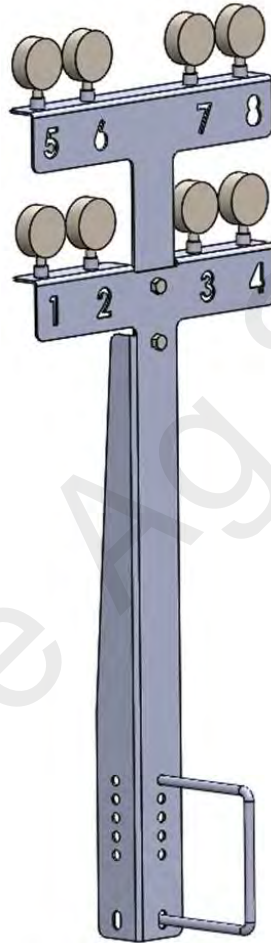

Safety Reminder

Anyone working around anhydrous ammonia should keep a small squeeze bottle of fresh water with him at all times.

Ag Leader Controller Setup for NH₃

Read the Ag Leader Operator's Manual for complete setup and operation instructions.

All personnel working with anhydrous ammonia must be properly trained in safe handling and operating procedures before working with this system.

Always double-check to be sure that all conditions are safe before opening the nurse tank valve or before turning on the system to release anhydrous ammonia.

This manual does not show all of the setup that must be done for your system. The Implement setup with width and sections must be set up for your configuration.

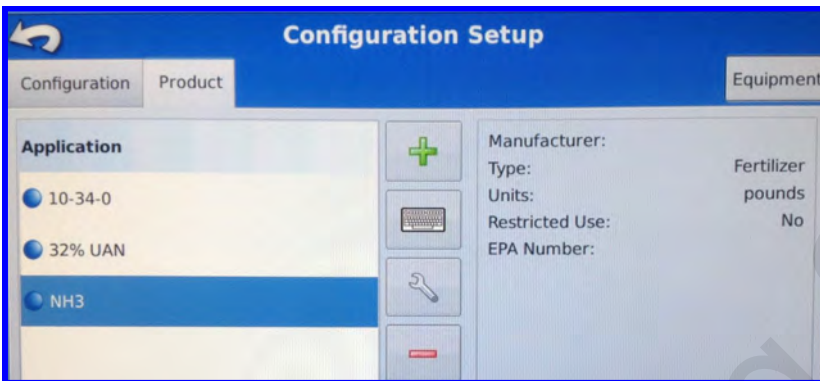

Under the **Configuration Setup > Product Tab** add or set up the NH₃ product.

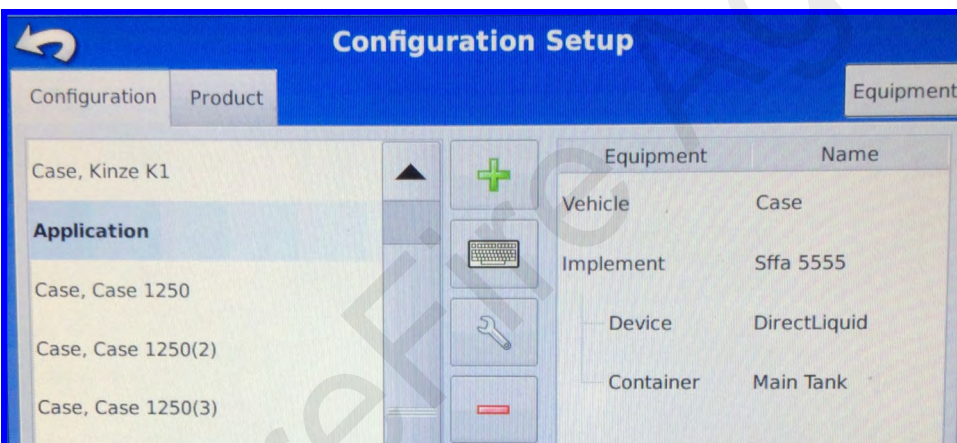

Configuration Setup > Configuration

Select an **Application** or create a new **Application** Operating Configuration by pressing 

and choosing **Application**.

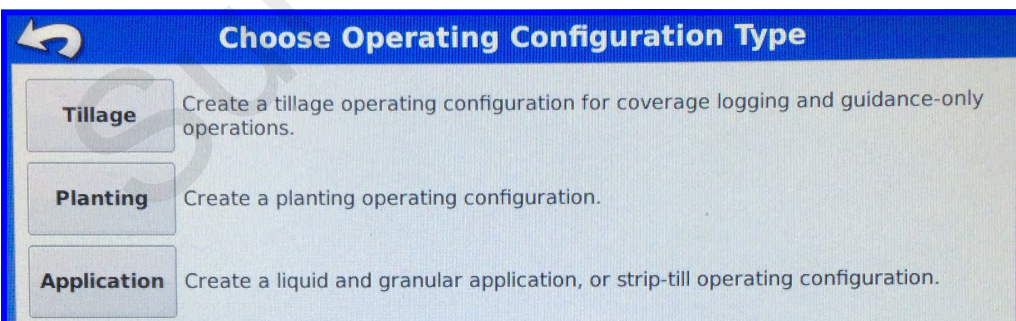

Ag Leader Configuration Setup (Continued)

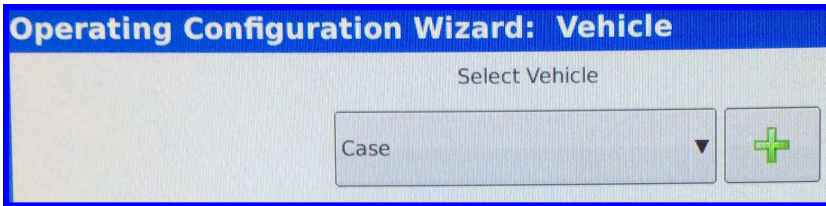

Select or create a new Vehicle and Implement for this Application configuration.

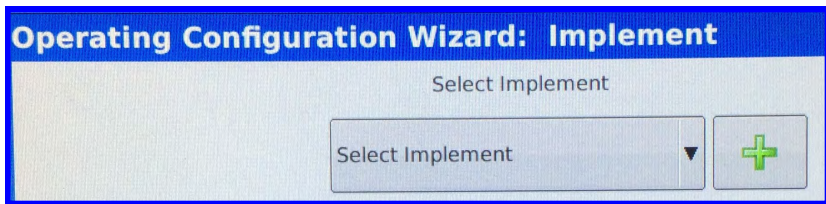

Ag Leader Integra Control Settings and Control Valve Settings

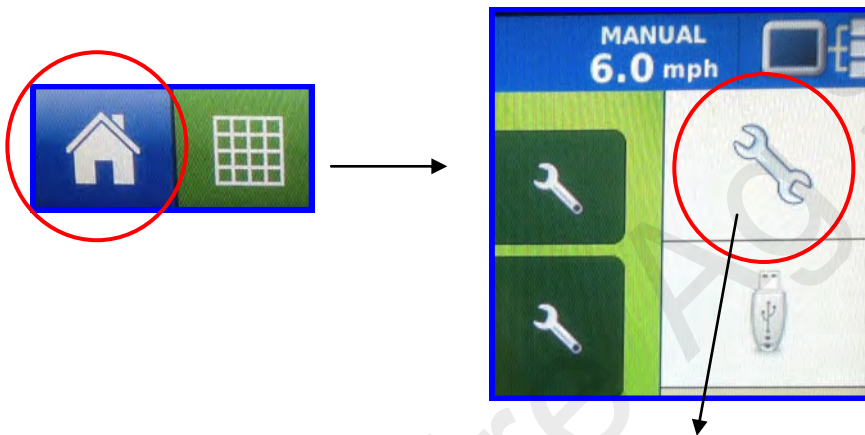

These screenshots show the buttons that will take you to the Control Settings and Control Valve Settings screens.

The setup for those screens is shown on the next page.

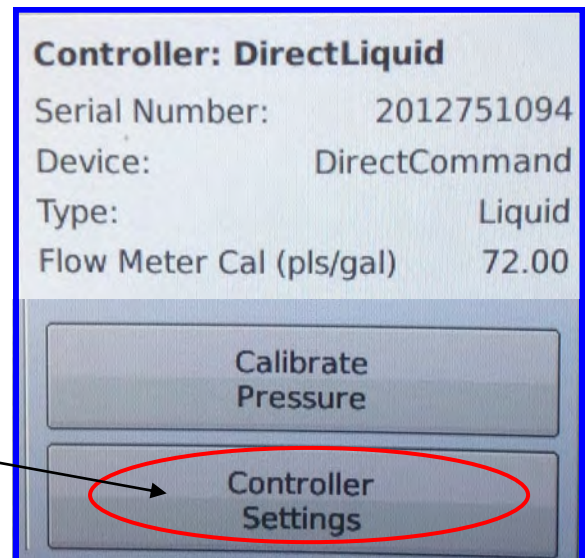
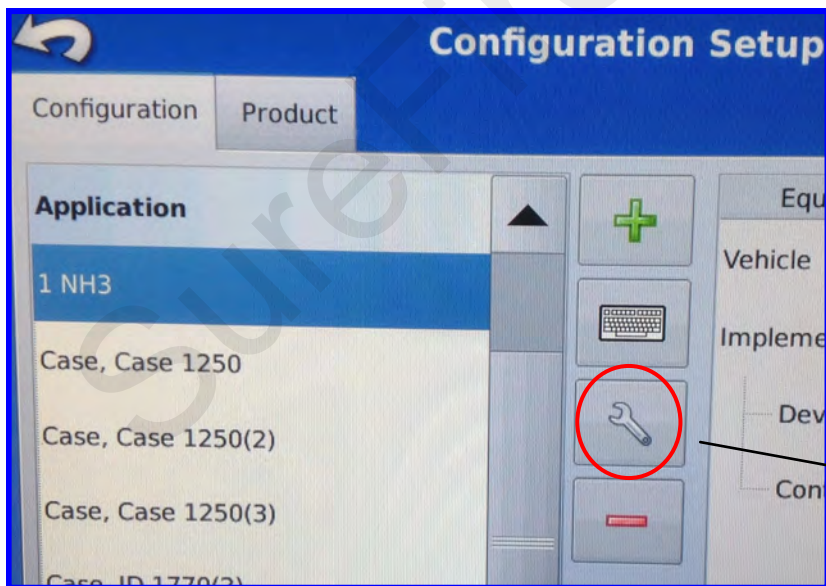

Ag Leader Integra Control Settings and Control Valve Settings

These screens shows the **Controller Settings** to start with. Your settings may need to be adjusted to fine-tune the operation of your system.

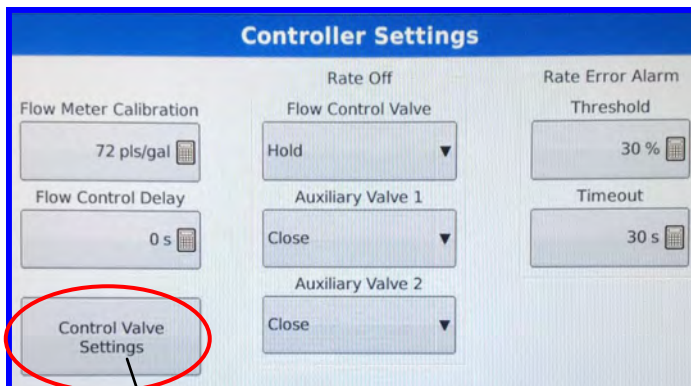

Flow Meter Calibration 72 pls/gal
Flow Control Delay Typically 0, may be set to 1 or 2 sec. to keep controller from adjusting for the first 1 or 2 sec. of operation.
Rate OFF Flow Control Valve Hold
Auxiliary Valve 1 (this is the Master ON/OFF) Close
Timeout can be adjusted from 5 to 30 seconds. Set this at 30 sec. when first setting up the system or when troubleshooting control issues so you won't get error messages during initial control testing.

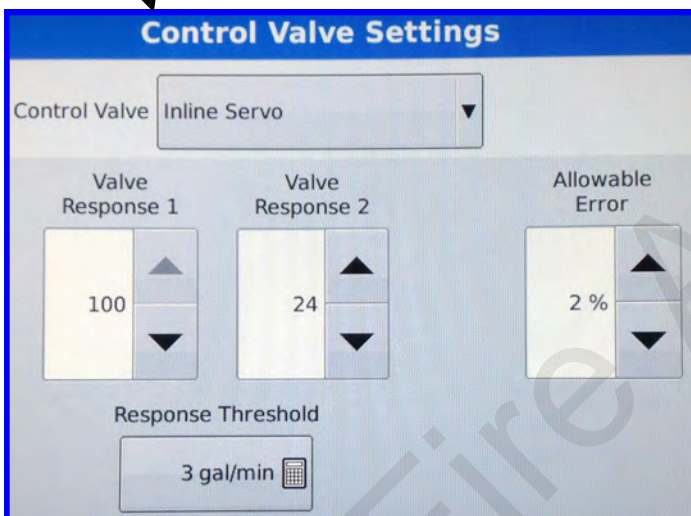

Control Valve Inline Servo
Valve Response 1 100 (This is the Fast speed of the servo valve. It controls how fast the valve runs when it is farther away from the rate—past the threshold)
Valve Response 2 24 (This is the Slow speed of the servo valve. The valve runs at this speed as it gets closer to the rate—within the threshold).
Response Threshold Start at 3 gal/min Lower the Response Threshold if the valve is too slow in getting to the Target. Raise if it consistently overshoots. Valve Response 2 can also be lowered to slow down the valve as it approaches the Target, or raised to get it to the Target quicker. Many times, an adjustment of the Response Threshold is all that is required to fine-tune system performance.

Allowable Error 2%
 The system will not make any control adjustments if the applied rate is within 2% of the Target Rate. If this is set too low, the system can get unstable by trying to respond to every slight deviation from the Target Rate.

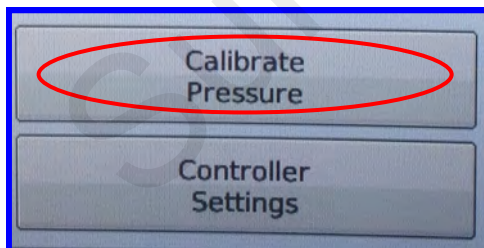

Optional Pressure Transducer—The 0-400 PSI transducer will be set up at 12.5 mV/ PSI.

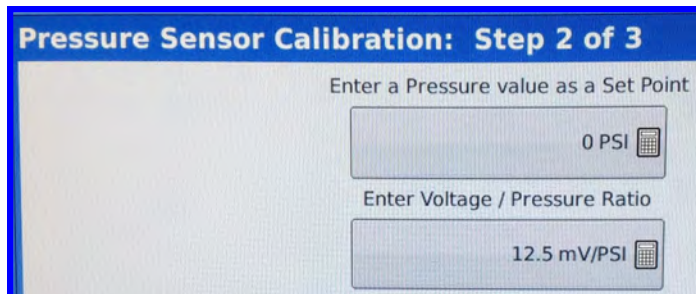
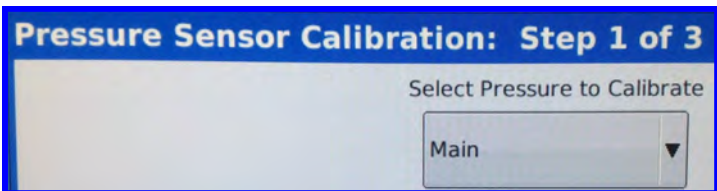

Ag Leader Display Setup (Continued)

The Grid button in the lower left corner of the screen brings up the Map screen for Run Time Operations.

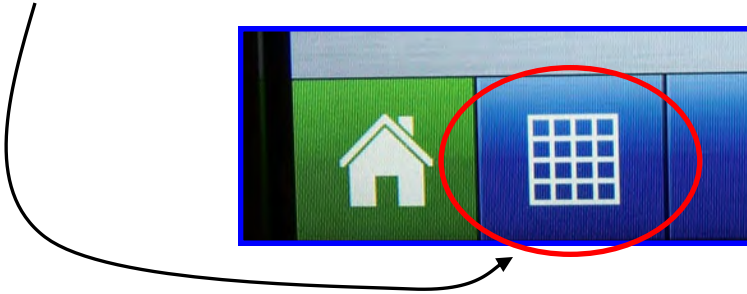

The **Product Tab** is in the upper right corner of the Map screen.

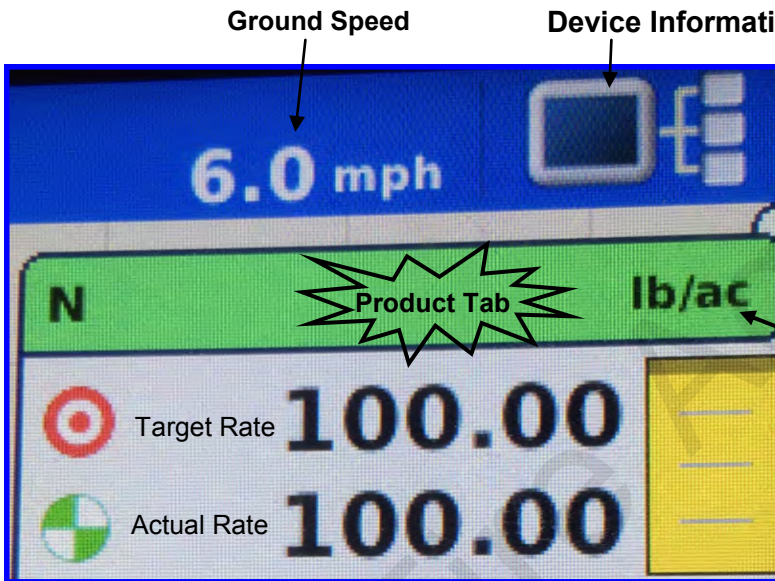

Press on the Device Information Button, then highlight the item marked **DC Liquid**, then press the **Diagnostics** button. The Liquid Diagnostics screen contains the Active Controller Name and Serial Number of the module. Also included are Main (1) and Auxiliary (2) Pressure readings, and Flowmeter Signal Frequency and Pulse Count. This can sometimes be useful troubleshooting information.

Press the **Product Tab** to bring up an extended view.

See the next page for further explanation of the items available on the Map screen.

Map Screen Product Control Toolbox

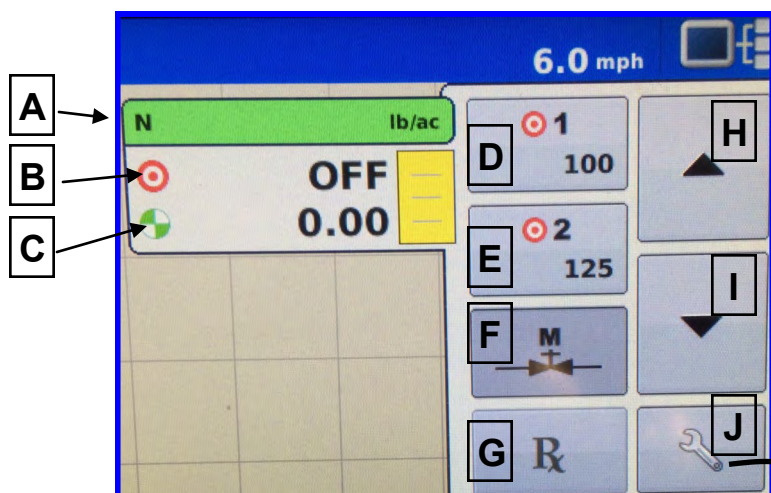

- A** Product
- B** Target Rate
- C** Actual Rate
- D** Rate 1 button
- E** Rate 2 button
- F** Manual Valve Control
- G** Prescription button
- H** Rate Increase arrow
- I** Rate Decrease arrow
- J** Rate Setup button

Set Rate 1, Rate 2, and Increment here:

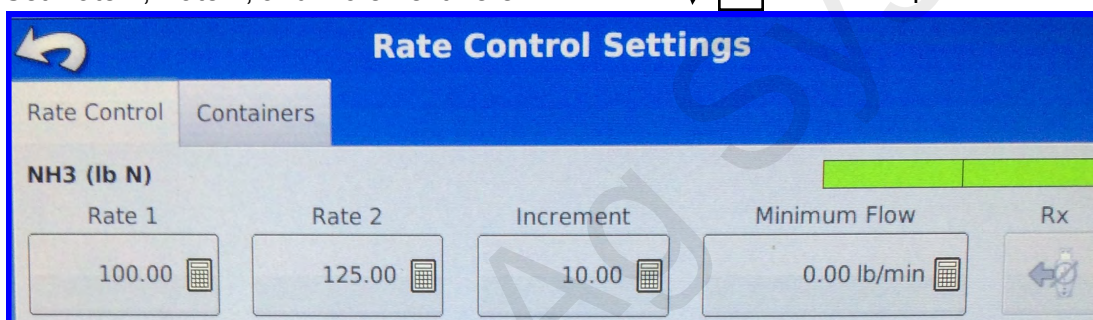

Do this before opening nurse tank valve:

Manual Valve Control to test operation of Control Valve

Make sure the nurse tank valve is closed and the Master On/Off Valve is in the OFF position.

1. Press the Rate 1 button, then press the Manual Valve Control button. → 
2. Press and hold the up arrow (H). The NH₃ control valve should open.
3. Press and hold the down arrow (I). The NH₃ control valve should close.

Master On/Off Valve Test and Section Valve Test

Make sure the nurse tank valve is closed. **CAUTION: Anhydrous ammonia will still be released if the system has been operational and any anhydrous ammonia is present in the system before the section valves. Bleed system or take necessary precautions.**

1. Select Rate 1 or Rate 2 and then press the Manual Valve Control Button .
2. Flip the master switch on and at least one section switch if electric section valves are used. The Master On/Off valve should open. Test each section switch to be sure each section valve is working. The Master On/Off valve should be open if at least one section is ON. The Master On/Off valve should close when all sections are OFF.

Wire Size: 18 AWG unless otherwise specified

201-215468 Y3

Length: 2ft

Ag Leader Adapter Cable twin 16 Pins

12 Pin Boom Connector – Deutsch DT06-12S Female

Section 1	1
Section 2	2
Section 3	3
Section 4	4
Section 5	5
Section 6	6
Section 7	7
Section 8	8
Section 9	9
Section 10	10
Section 11	11
Section 12	12



12 Pin Aux Connector – Deutsch DT06-12S Female (Black Connector)

Agitation Pressure

Pressure 1 (Main)



Aux Valve 1

Aux Valve 2

Impl Switch Signal

Pressure 2 (AUX)

Impl Switch GND

1
2
3
4
5
6
7
8
9
10
11
12

8 Pin Channel 1 (PWM and Flow) Connector – Deutsch DT06-08S Female

Servo +/-PWM

Flow Signal

Flow GND

Servo +/-PWM

1
2
3
4
5
6
7
8

2 Pin (Power In) Connector – Deutsch DTP04-2P Male



+12VDC

Ground

1
2

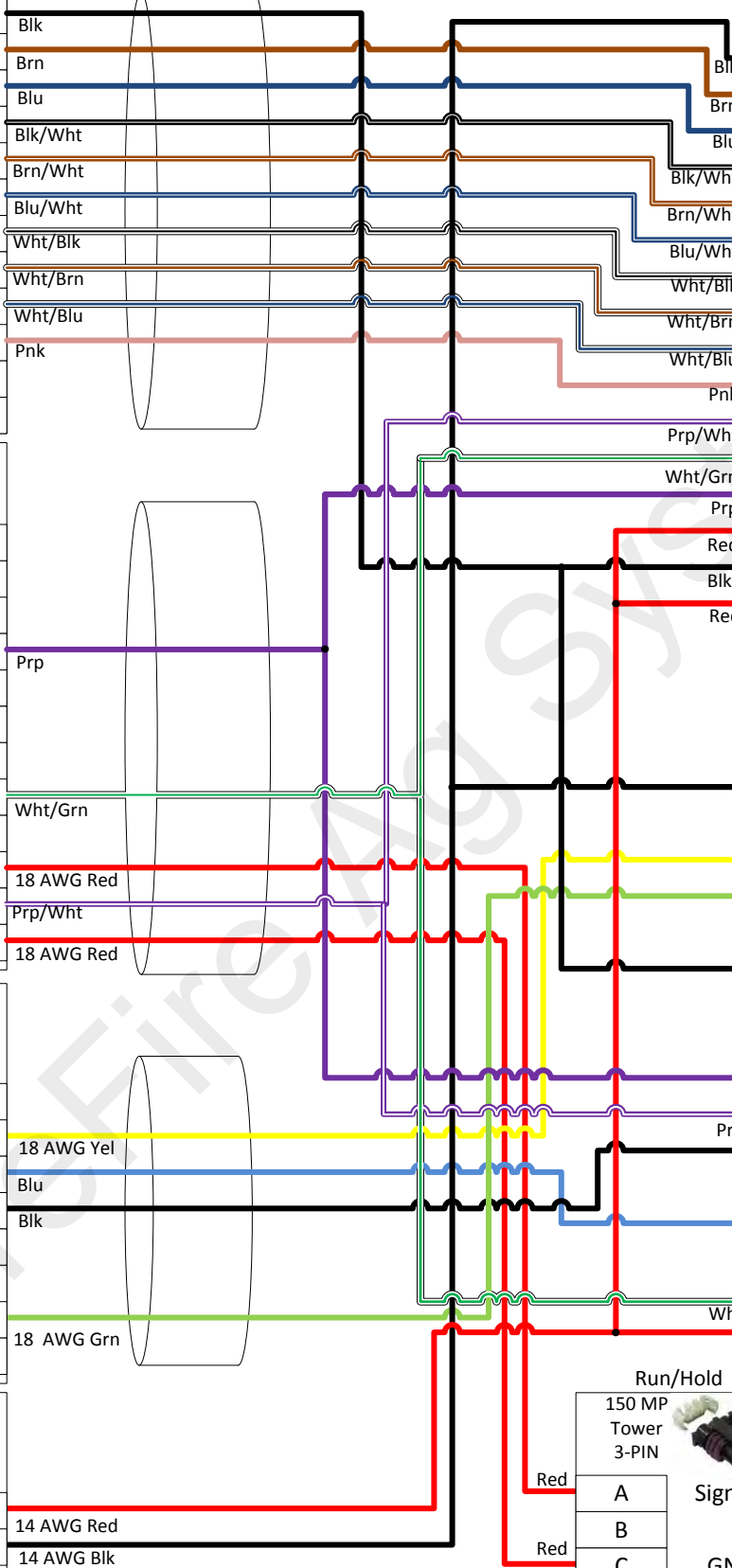

16 Pin Round – AMP Male pins in male body (with threads for swivel nut)

1	Valve GND
2	Section 2
3	Section 3
4	Section 4
5	Section 5
6	Section 6
7	Section 7
8	Section 8
9	Section 9
10	Section 10
11	Pressure 2(AUX)
12	Aux Valve 1
13	Pressure 1 (Main)
14	Valve Power
15	Section 1
16	Valve Power

Attach Dust cover to Connector

Labeled "Sections"



16 Pin Round – AMP Female pins in female body (with swivel nut)

1	GND
2	
3	Servo +/- PWM
4	Servo -/ PWM
5	
6	Section 1
7	Labeled "To Pump"
8	
9	Pressure 1 (Main)
10	Pressure 2 (AUX)
11	Flow GND
12	
13	Flow Signal
14	
15	Master On/Off
16	Power



Run/Hold



A	Signal
B	
C	GND



Signal	A	18 AWG Red
	B	
GND	C	



Project:	201-215468 Y3	Drawn By:	Albert Popp Rev. by Mark Wolters
Filename:	Ag Leader Adapter Cable twin 16 pins (2 Pressure and Aux Valve 1)	Date:	10/7/2011 Rev. 09/24/2013 01/13/2015
Copyright 2011-2015 SureFire Ag Systems		Page of Pages	1 of 2

207-2292Y1

NH3 Control Cable- Flow Meter, Servo, Master On/Off, & Pressure

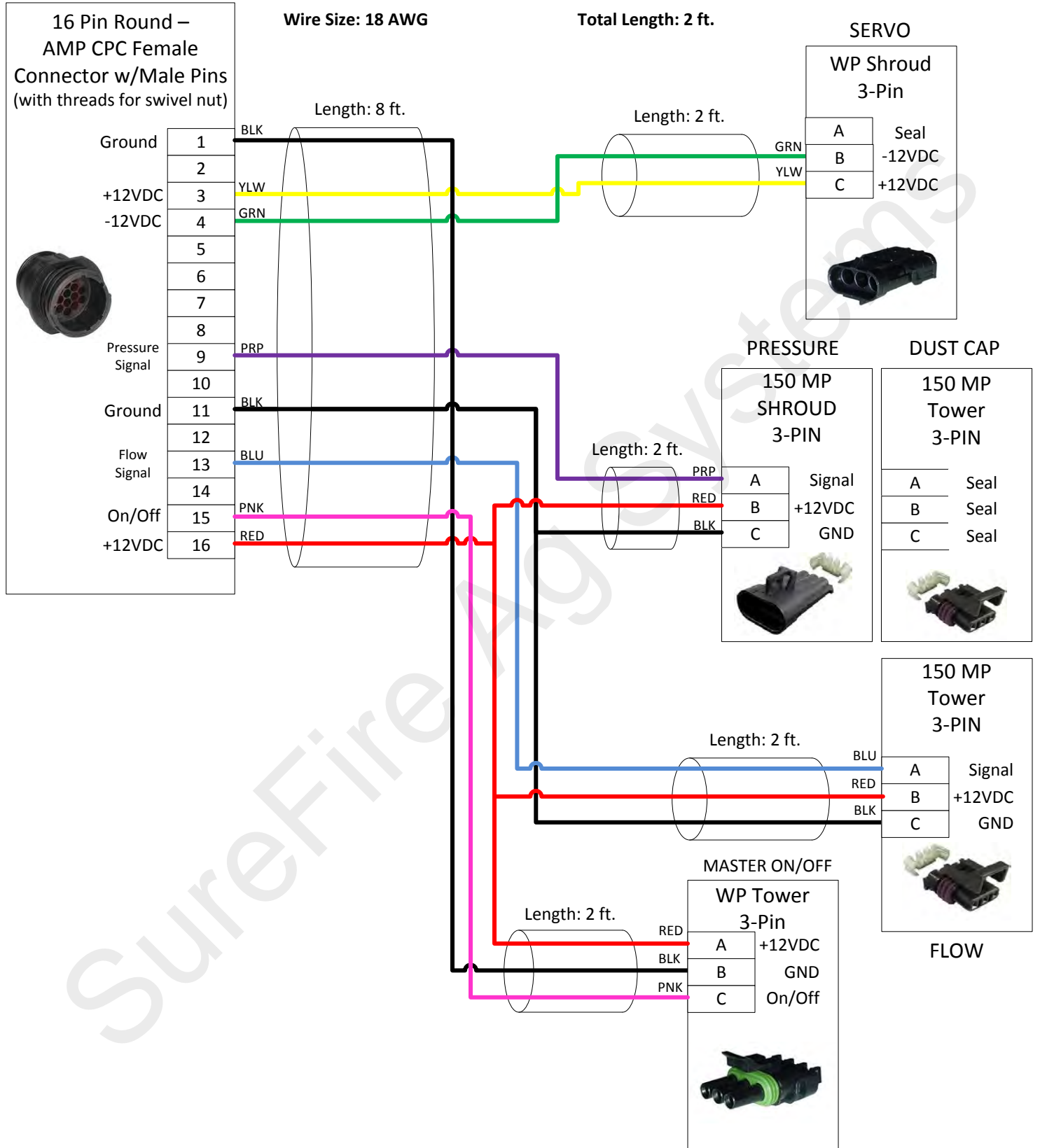

Project:	207-2292Y1	Drawn By:	Brady Gragg
Filename:	NH3 Control Cable- Flow Meter, Servo, Master On/Off, & Pressure	Date:	Date: 3/27/13
Copyright 2013 SureFire Ag Systems		Page of Pages	1 of 1

207-215466 Y2

6 Section Boom Harness w/ 2 Pressure and Flow Return Valve

All wire gauge 18 AWG
Unless Specified

Wire Length: 10'

Put booms 1-6, Flow Return and Pressure 1-2 in one loom 10' long

Provide dust caps for WP and MP connectors

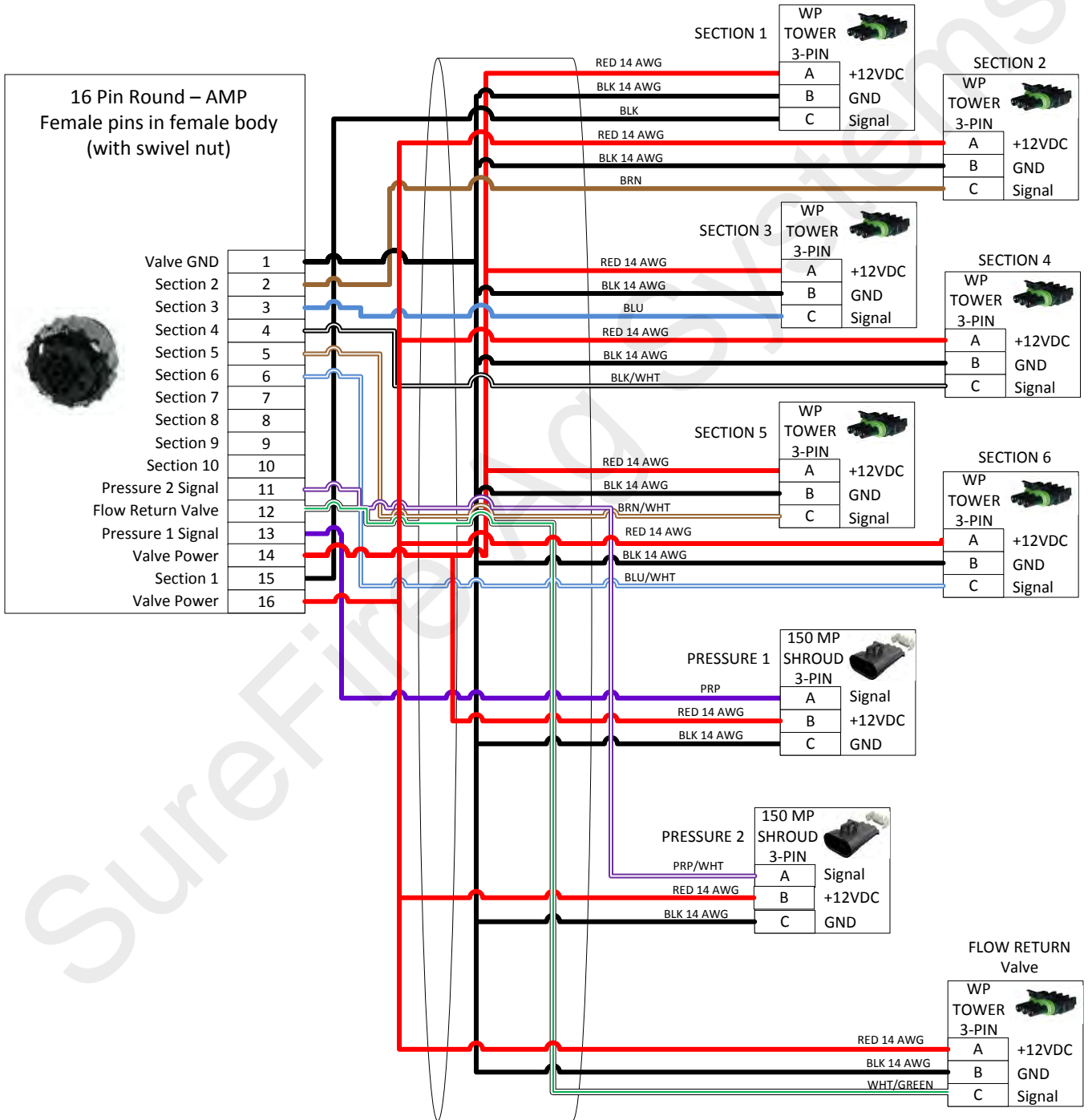

Project:	207-215466 Y2	Drawn By:	Dirk Ricker Rev. by Mark Walters
Filename:	6 Section Boom Harness w/ 2 Pressure and Flow Return	Date:	9/12/2012 08/20/2013
Copyright 2012-2013 SureFire Ag Systems		Page of Pages	1 of 1

Read and save all product literature, installation instructions, and operating instructions that accompany this system.

Make sure all personnel that will be operating or working around this system have been properly trained in safe anhydrous ammonia practices.

See page 35 for instructions on checking operation of Control Valve, Master On/Off Valve and Electric Section Valves before opening the nurse tank valve.

On first use with anhydrous ammonia, be certain that all personnel are in a safe place as the nurse tank valve is opened and as each segment of the system is filled with anhydrous ammonia. Verify that all joints and connections are tight and that proper shut-off and control of the system is working.

TORPEDO™



SureFire

Ag Systems

© 2015 SureFire Ag Systems-All Rights Reserved