

396-001470

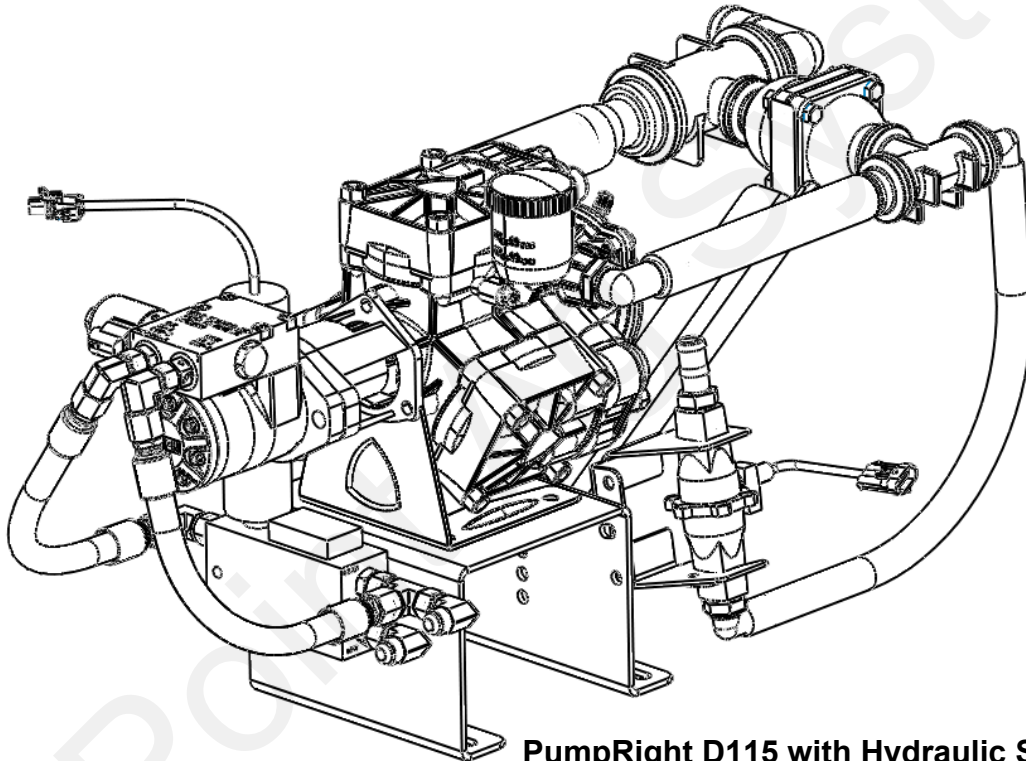

General Instructions for PumpRight Pump & SERVO Hydraulic Valve



PumpRight D115 with Hydraulic Servo Valve and Turbine Flowmeter

PumpRight pumps are available in 4 models to fit your implement size and application rate. At maximum flow, all pumps use 10 - 11 GPM of hydraulic oil. To minimize the oil requirement consider using the next larger size pump.

	Number of Diaphragms	Max Flow GPM	Max GPA on 40' at 6 MPH	Max GPA on 60' at 6 MPH
D70	2	15	30	20
D115	3	25	50	34
D160	4	35	70	48
D250	6	55		70

PumpRight Accessory - Ion Flow Meter Kits

- 0-6—13 GPM Item Number 500-02-2060
- 1.3—26 GPM Item Number 500-02-2070
- 2.6—53 GPM Item Number 500-02-2080

B

Components
Liquid

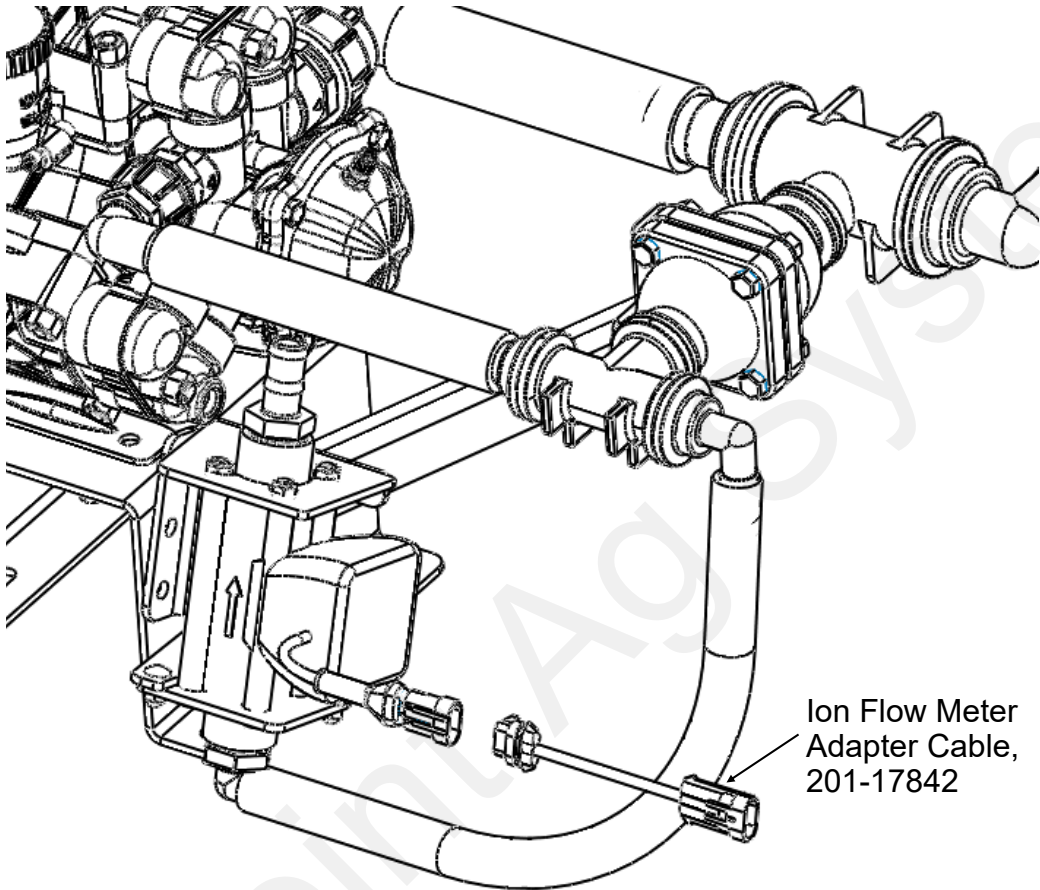

Ion flowmeters are superior to traditional turbine flowmeters in two basic ways. First, they have no moving parts. This translates into no wear items or potential for contaminants to jam a spinning turbine.

Second, ion flowmeters detect the flow of ions which makes them independent of viscosity or density of the fluid measured. They are extremely accurate using the standard calibration number. SurePoint still recommends you perform a catch test to verify the system is properly installed and configured.

Flow Meter Size	FPT Size on Meter	Hose Barb Size in Kit
0-6—13 GPM	3/4"	1"
1.3—26 GPM	1"	1"
2.6—53 GPM	1 1/4"	1 1/2"



B

Components
Liquid

Pump Priming and Air Bleed Valve

An air bleed valve is included with each pump to aid in system priming. It is shipped in the pump accessories bag and must be installed during system installation.

Why use an air bleed valve:

Most fertilizer systems are equipped with a 4-10 lb check valve on the end of each hose delivering fertilizer to the ground. These valves do not let air escape from the system, unless it is pressurized. PumpRight liquid pumps are not good air compressors. Therefore, the pump can struggle to prime due to air trapped on the outlet side of the pump.

The air bleed valve is a small 1/4" valve that when opened lets air escape from the pump outlet at zero pressure. Open until liquid comes out and then close the valve.

How to install the air bleed valve:

Remove the 1/4" plug from the quick connect fitting on the pump outlet side (see pictures below). Next, insert the 1/4" tubing in the quick connect fitting. Run the 1/4" tubing to an easily accessible spot on your equipment. Next, cut the tubing and push the 1/4" valve onto the tubing. Finally, run the tubing to a low location where any fertilizer that escapes will run on the ground.

D115 & D70

Attach 1/4" tubing to 1/4" QC on bottom of 1" Manifold Cross

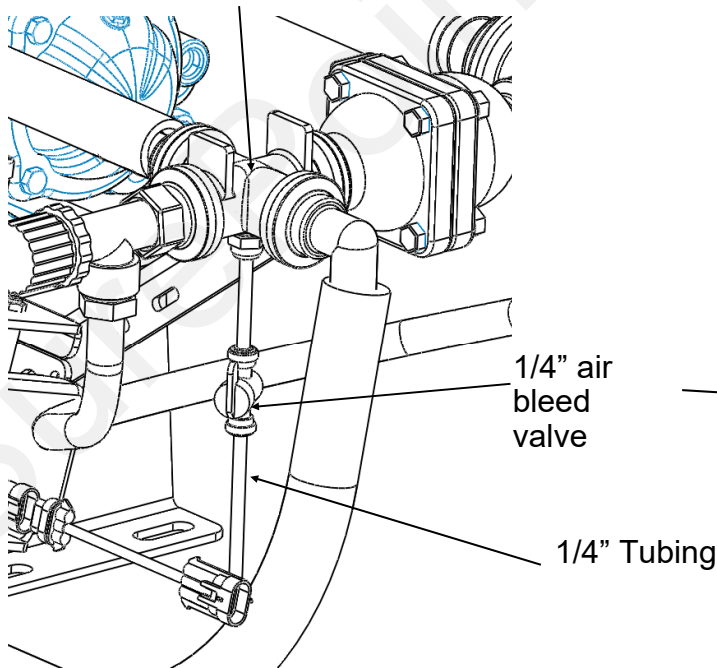

D160 & D250

Attach 1/4" tubing to 1/4" QC on back side of 1" x 2" tee on outlet side of pump

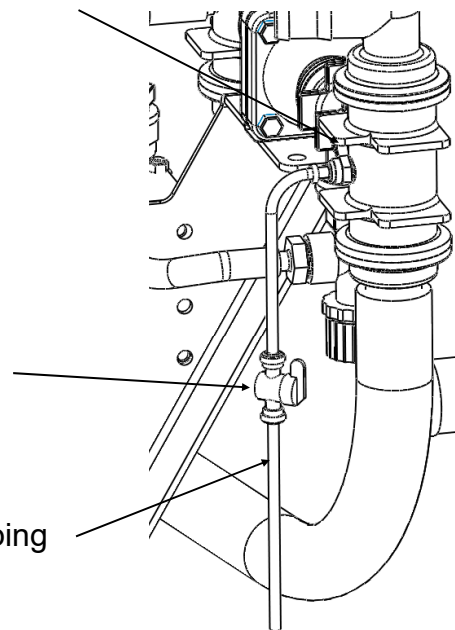

Recirculation & Agitation

A recirculation valve is standard on the all 4 PumpRight models outlet plumbing assembly.

How Recirculation Works:

When running a PumpRight pump at less than 20% of it's maximum flow, it sometimes improves system stability to allow the pump to run faster. Opening the recirculation valve diverts some pump flow before the flowmeter, causing the pump to run faster. The application rate is still measured by the flowmeter and everything that passes through the flowmeter is applied to the ground. If the pump is surging at a low flow rate, open the recirculation regulation valve until the pump runs smoothly. **OPENING THE VALVE LOWERS THE MAXIMUM RATE THAT CAN BE APPLIED TO THE GROUND.** Close the valve if a higher rate is required.

How to modify for tank agitation:

If tank agitation is required, the recirculation valve can be re-plumbed to divert flow to the tank. All that is required is to remove the 1/2" recirculation hose from the pump. Then replace the 3/8" MPT x 1/2" HB on the inlet side of the pump with a 3/8" plug which is included in your PumpRight accessories bag. Finally, install a longer 1/2" hose from the recirculation valve back to the tank.

D115 (D70 very similar)

D160 (D250 very similar)

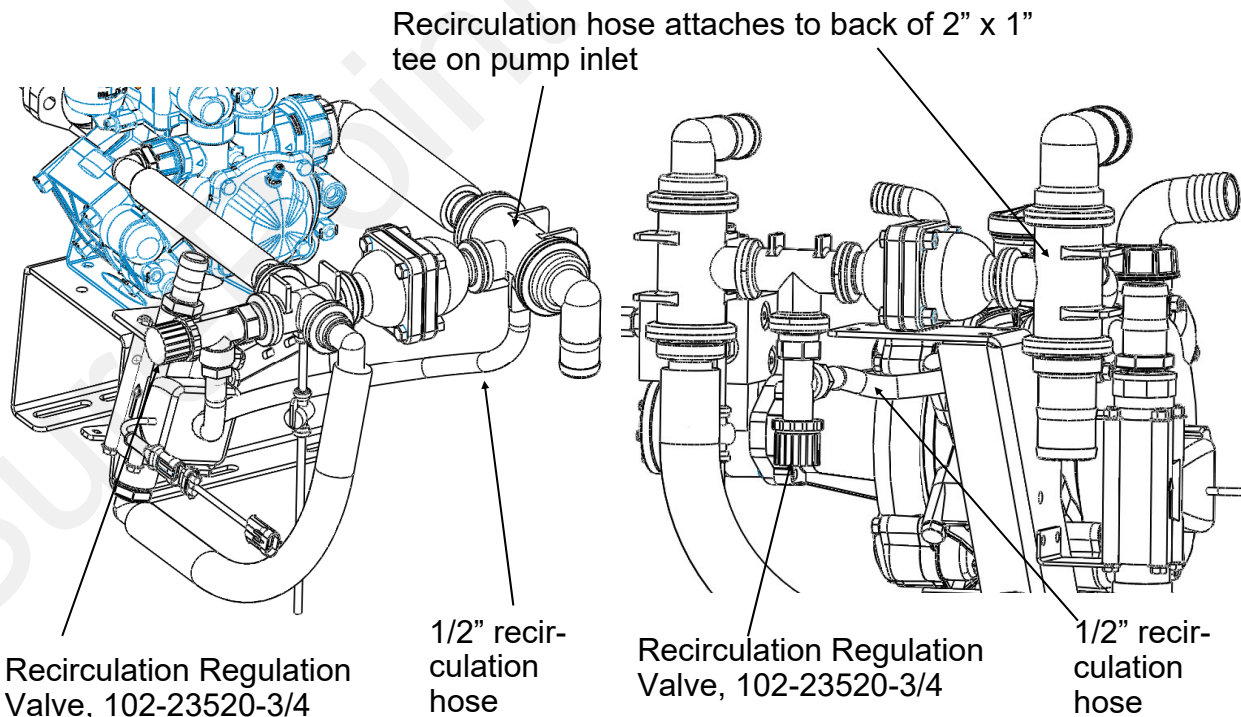

PumpRight Pump Installation



Mounting

1. Mount pump in your preferred location. The PumpRight pump has excellent suction and priming ability, so it can be mounted away from or above fertilizer tanks.
2. SurePoint has U-Bolts available to mount the pump directly to multiple bar sizes shown below. If the U-Bolts will not work, order the universal backer plate kit, number 515-203000 which will clamp to any size tube from 4" - 8" wide.

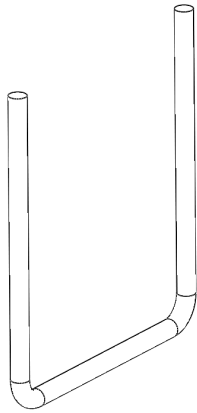

Mounting Bar Size	Item Number	Item Description
4" W x 4" T	301-0804000500-05	Square Bend U-Bolt - 1/2" x 4" x 5"
5" W x 7" T	301-0805000850-05	Square Bend U-Bolt - 1/2" x 5" x 8-1/2"
6" W x 4" T	301-0806000500-05	Square Bend U-Bolt - 1/2" x 6" x 5"
7" W x 7" T	301-080700-05	Square Bend U-Bolt - 1/2" x 7" x 8 -1/2"
7" W x 5" T	301-0807000600-05	Square Bend U-Bolt - 1/2" x 7" x 6"
8" W x 12" T	301-0808001350-05	Square Bend U-Bolt - 1/2" x 8" x 13 1/2"
8" W x 16" T	301-0808001750-05	Square Bend U-Bolt - 1/2" x 8" x 17 1/2"

PumpRight Hydraulic Connections— Hydraulic Servo Valve

E

Installation
Overview

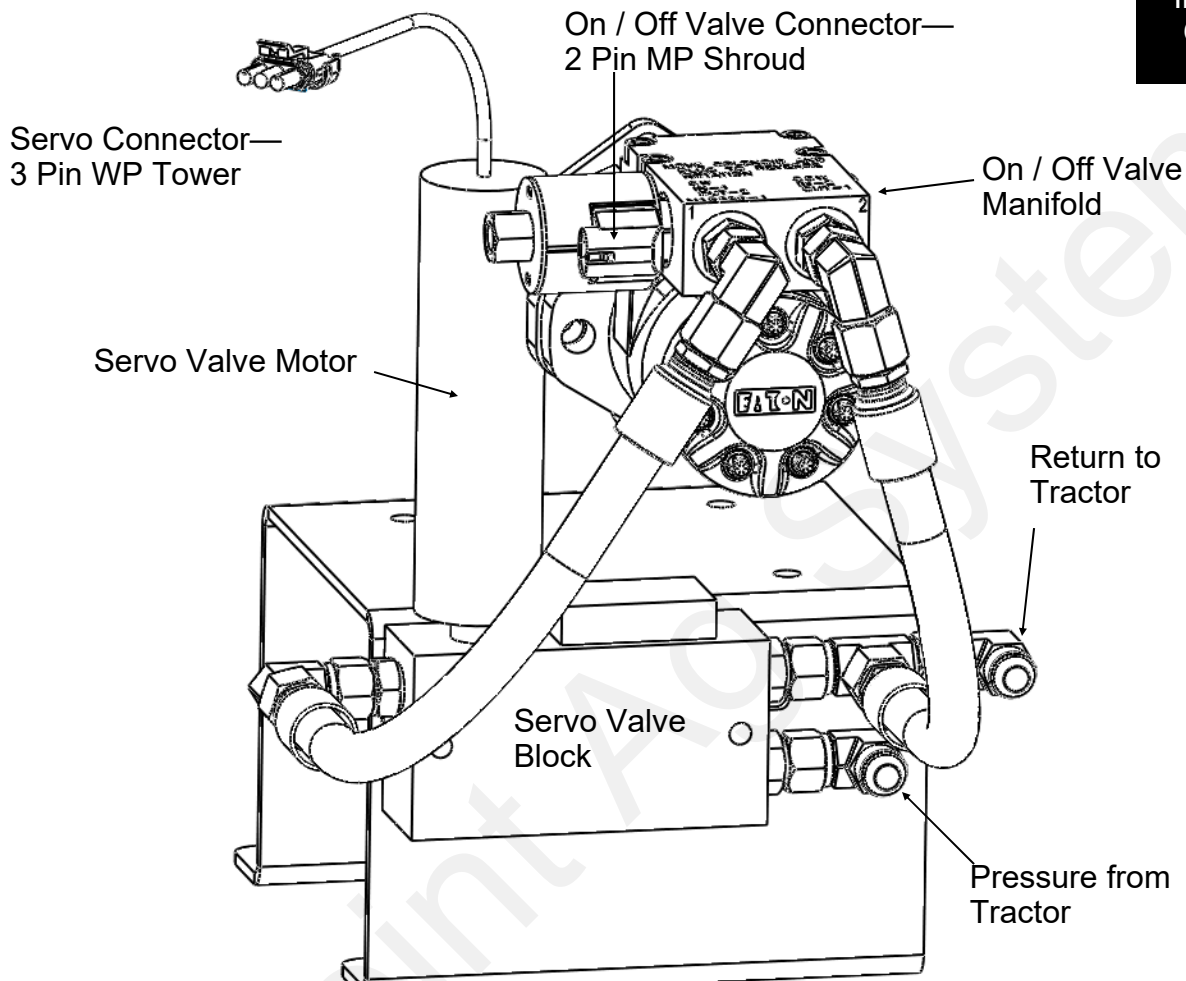

Hydraulic Connections

1. Two hoses will be required from tractor remote valve to PumpRight Pump. We recommend 1/2" hydraulic hose. The hoses will need a #8 (1/2") Female JIC Swivel to connect to the PumpRight pump.
2. Connect the hoses as shown in the pictures.

How it Works

The servo valve turns to vary a hydraulic passage which regulates how much oil flows out the "CONTROLLED" port. This oil is constantly flowing to the motor manifold. The On / Off Valve in the manifold closes to force the oil through the motor. At rest (zero volts), the On / Off Valve is open, this allows oil to flow freely from port 1 to port 2, and the motor is stopped. When energized with 12 volts, the On / Off valve closes, forcing the motor to rotate.

PumpRight Hydraulic Connections— Hydraulic Servo Valve

E Installation Overview

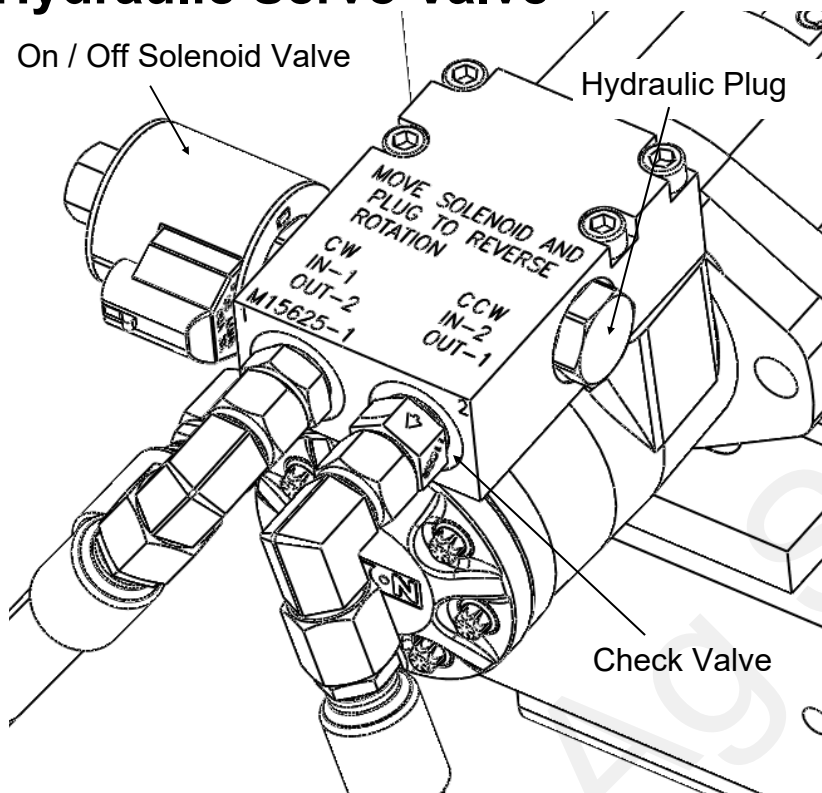

The motor on the PumpRight pump turns in a clockwise rotation, looking at the shaft. The solenoid and plug should be installed as shown at left. A check valve is installed on the #2 (outlet) port. This prevents the motor from rotating backwards. The check valve can be identified by its slightly larger size, flow arrow and the part number "1108R" stamped on it.

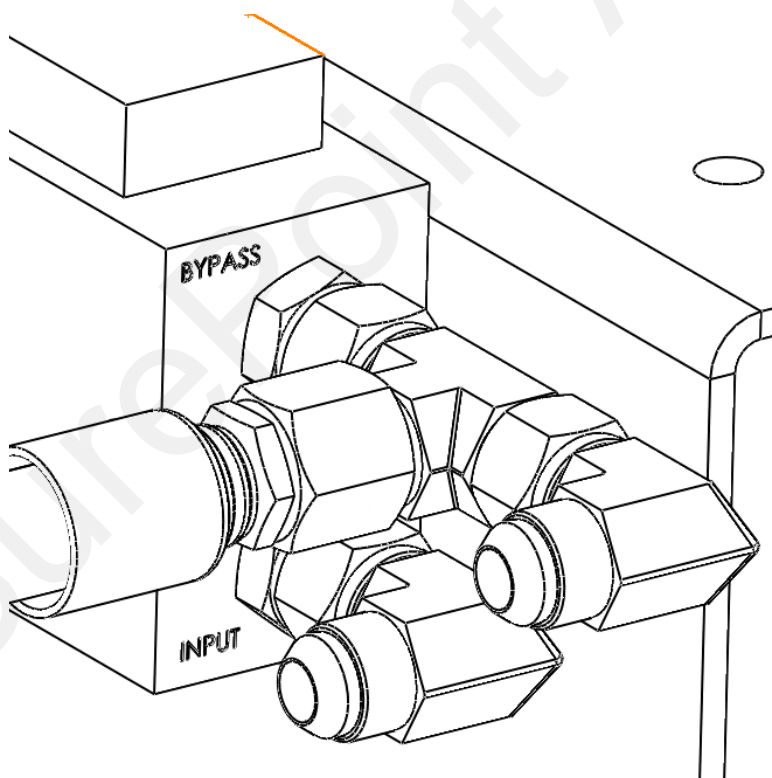

The servo valve block has labeled ports. The "BYPASS" port uses a tee to combine the valve bypass flow with the motor return flow. Then the combined flow is returned to the tractor.

The "INPUT" port is connected to the tractor pressure port.

The 3rd port on the opposite end of valve (not shown) is labeled "CONTROLLED" and is connected to the motor inlet, port #1.

PumpRight Hydraulic Connections

E

Installation
Overview

Hydraulic Hose

SurePoint recommends 1/2" hydraulic hose for both pump inlet and outlet. The hoses will need #8 JIC female swivel fittings.

Where do I get hydraulic flow for my PumpRight?

This question is often asked as many implements use up all the hydraulic connections on a tractor. SurePoint has some recommendations as to what works best.

Best Option - Dedicated PumpRight Circuit

If you have a tractor remote available, attach the tractor remote valve directly to the PumpRight pressure and return ports. DO NOT try to avoid this method simply to save another set of hydraulic hoses running to the tractor. Operating the PumpRight on it's own circuit is the simplest for installation and operation. It guarantees the PumpRight won't negatively affect any other hydraulic components on your equipment.

Preferred

Alternate Option - In Series with John Deere CCS Fan or Bulk Fill Seed Fan

If you do not have a tractor remote valve available, this may be your best method. You can plumb the PumpRight after the seed distribution fan. If using this method, the SurePoint PWM bypass valve must be open (see previous page for instruction & picture). If bypass is left closed, the SurePoint valve will limit the speed of the seed distribution fan.

For example, the John Deere CCS fan uses around 7 GPM of oil. This will limit the PumpRight maximum flow (10 GPM oil necessary for maximum flow). See the charts on the next page for adjusted maximum pump flow. See section G for flow charts to determine your necessary flow rate. If you absolutely need the maximum flow in this case, SurePoint has an alternate motor (smaller displacement) to increase pump speed at 7 GPM oil flow.

DO NOT plumb the PumpRight in series with a vacuum fan. The vacuum fan uses just a few GPM of oil. Also, problems will be caused by excessive pressure at the vacuum fan motor

Two PumpRights

The preferred method is to plumb the two pumps in series. DO NOT plumb two pumps after the CCS fan. Excessive pressures may damage the CCS fan motor. Run the pressure line from tractor to first pump inlet. Plumb from the outlet of Pump 1 to the Inlet of Pump 2, then from Pump 2 outlet back to the tractor. Open the bypass needle valve on both pumps so each valve controls motor speed independently. Run the flow setting procedure on the next page to minimize the hydraulic flow based on the pump that requires more hydraulic motor flow.

PumpRight Hydraulic Oil Flow Requirements



PumpRight pumps require a constant hydraulic oil flow from the tractor. The amount of oil needed varies with pump size and speed. The chart at right shows the necessary oil flow for each pump model at varying fertilizer flows.

Model D70 - 2 Diaphragms

Fertilizer Flow (GPM)	Pump Speed (rpm)	Hydraulic Oil Flow (GPM)
5	156	3.5
10	313	7.0
15	469	10.5

Use this procedure to determine the correct setting on your tractor hydraulic flow.

1. Run the fertilizer system in the field at the maximum rate and ground speed.
2. Turn down the hydraulic flow slowly while watching the pump flow (Volume / Minute).
3. Observe when the Volume / Minute begins to drop.
4. Turn the hydraulic flow back up slightly

This setting will provide the Pump Right pump just enough oil for your application rate.

If running with the bypass open (only recommended when 2 motors are operated in series) this process will minimize the oil circulated in the bypass loop, leaving more oil flow for other hydraulic functions.

Model D115 - 3 Diaphragms

Fertilizer Flow (GPM)	Pump Speed (rpm)	Hydraulic Oil Flow (GPM)
5	94	2.1
10	189	4.2
15	283	6.3
20	377	8.4
25	472	10.5

Model D160 - 4 Diaphragms

Fertilizer Flow (GPM)	Pump Speed (rpm)	Hydraulic Oil Flow (GPM)
10	135	3.0
20	270	6.0
30	405	9.1
35	473	10.6

Model D250 - 6 Diaphragms

Fertilizer Flow (GPM)	Pump Speed (rpm)	Hydraulic Oil Flow (GPM)
10	86	1.9
20	172	3.8
30	258	5.7
40	343	7.7
50	429	9.6
55	472	10.5

D70 & D115 Liquid Plumbing Connections

E
Installation
Overview

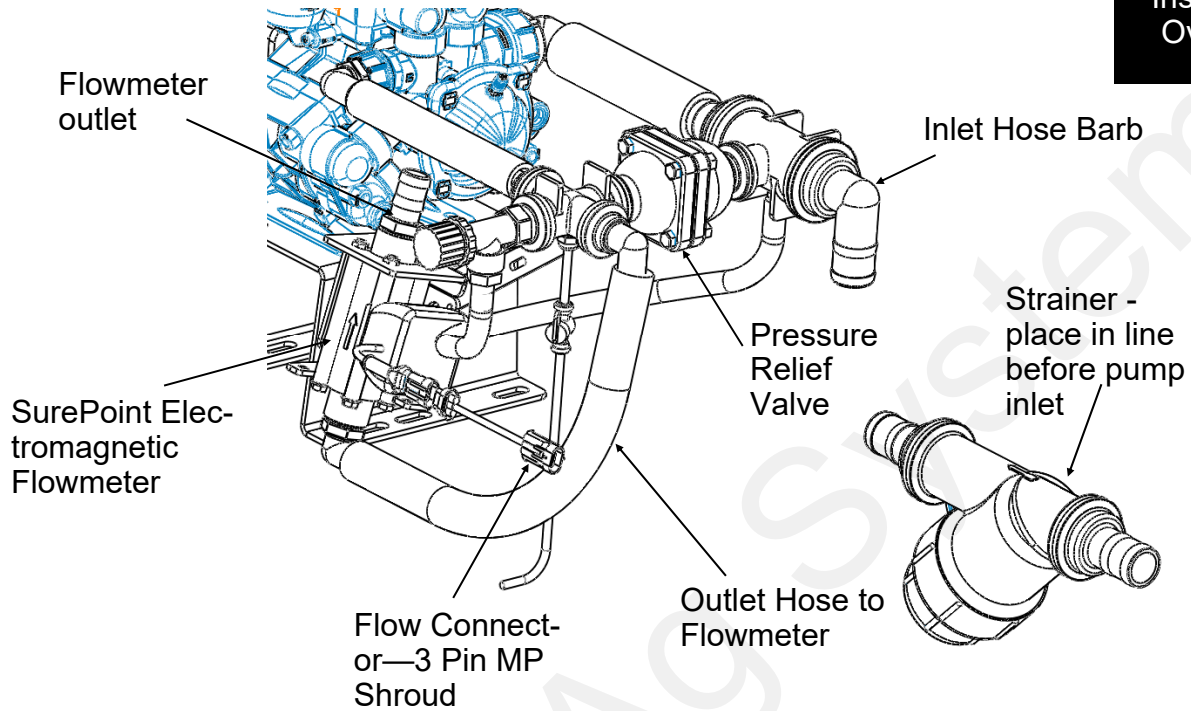

Inlet: The D70 and D115 PumpRight is shipped with a 1 1/2" inlet hose barb. Attach this to the hose from your supply tank and strainer . A 1 1/2" 90 degree hose barb is included and can be substituted.

Inlet Strainer: A 50 mesh strainer is included in the pump kit. The manifold strainer includes two hose barbs so it can be mounted anywhere in the inlet line. If space allows, the strainer can be mounted directly to the inlet plumbing assembly as shown below.

Outlet: The outlet is plumbed directly to the flowmeter with 1" hose. As shown above, the flow meter may be mounted directly to the PumpRight pump. The flowmeter outlet is a 1" hose barb. The outlet hose should be a minimum of 24" long with a gentle curve prior to any fittings for optimum flowmeter performance. The flowmeter outlet will attach to your manifold(s) or section valves. A 3/4" hose barb is included in the bag of parts and can be substituted on the flow meter outlet.

Pressure Relief Valve (PRV): The PRV is a 100 psi relief. If there is a restriction that creates over 100 psi in the system, the PRV will open allowing the excess flow to pass back to the inlet side of the pump. This protects the pump and fertilizer system from damage.

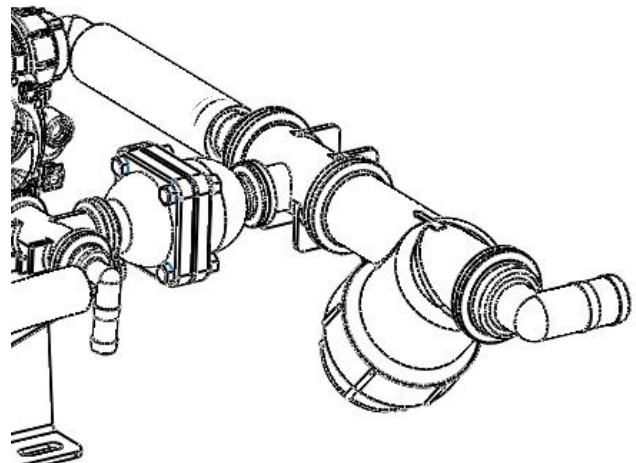

D160 & D250 Liquid Plumbing Connections

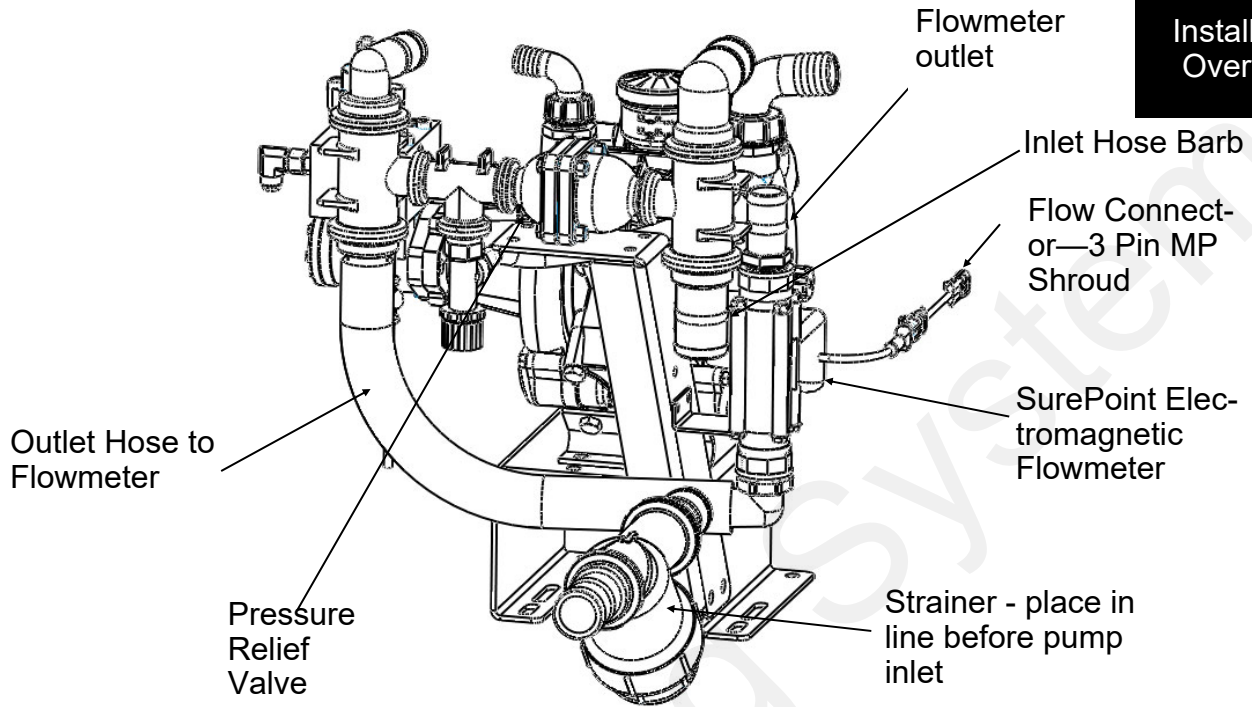

Inlet: The D160 and D250 PumpRight is shipped with a 2" inlet hose barb. Attach this to the hose from your supply tank and strainer . A 2" 90 degree hose barb is included and can be substituted.

Inlet Strainer: A 50 mesh strainer is included in the pump kit. The manifold strainer includes two hose barbs so it can be mounted anywhere in the inlet line. If space allows, the strainer can be mounted directly to the inlet plumbing assembly.

Outlet: The outlet is plumbed directly to the flowmeter with 1 1/2" hose. As shown above, the flow meter may be mounted directly to the PumpRight pump. The flowmeter outlet is a 1 1/2" hose barb. The outlet hose should be a minimum of 24" long with a gentle curve prior to any fittings for optimum flowmeter performance. The flowmeter outlet will attach to your manifold(s) or section valves.

Pressure Relief Valve (PRV): The PRV is a 100 psi relief. If there is a restriction that creates over 100 psi in the system, the PRV will open allowing the excess flow to pass back to the inlet side of the pump. This protects the pump and fertilizer system from damage.

Recommended Care and Maintenance

H

Maintenance
& Parts

Air Bladder

PumpRight pumps have an air bladder to smooth the pump output flow. It is recommended to run this bladder at 20% of working pressure. So if your system operates at 50 psi, charge the air bladder to 10 psi. Due to the small size of the air bladder, very little air is needed. SurePoint recommends charging a portable air tank to the correct pressure, then attach to the bladder valve to charge the air bladder to the same pressure as your air tank.

Winterization

SurePoint recommends flushing your fertilizer pump and complete system with adequate amounts of water first. Next, use RV antifreeze to winterize your system by pumping an adequate amount through all components. At the beginning of the next season, begin with water to verify the system is in working order with no leaks.

Change Pump Oil Annually

PumpRight pumps use an internal oil lubricated crankshaft and connecting rod design. The oil is held in an external reservoir with level indicators. Hypro oil is recommended for the pump. This is a non-detergent SAE30 weight oil. If not available, hydraulic jack oils are a similar non-detergent formulation. Annual oil changes are recommended.

To fill or drain the pump completely, the pump shaft must be turned slowly by hand. The hydraulic motor will have to be removed to do this.

On some pump models, the pump will have to be removed from the mounting bracket and lifted slightly to allow access to the oil plug.

When refilling the pump with oil, the shaft will again have to be rotated to fill the pump to its required oil volume.

Diaphragm & Valve Replacement

PumpRight pumps are designed to allow very simple replacement of the two main pumping components; the diaphragms and the inlet & outlet valves. It is a good practice to replace these annually. It is a small job that helps ensure reliable operation during the busy season.



Diaphragm Pump Valves & Diaphragms



All PumpRight models use the same diaphragm and valve parts.

Diaphragm Pump Service Kit Item Number 291-02-101500

1 Kit contains 1 diaphragm and 2 valves to service a single pumping diaphragm. Order multiple kits to service all the diaphragms in your pump per chart at right.

Qty in Kit	Part Number (all begin 291-02-9910-xxxxxx)	Description
1	550085	Diaphragm (Desmopan)
2	320030	O-Ring
2	759051	Valve Assembly

	Number of Diaphragms
D70	2
D115	3
D160	4
D250	6

Diaphragm & Valve Service Steps:

1. Drain oil from pump. Rotate pump shaft to remove all oil.
2. Remove pump manifold(s) using a 17mm or 13 mm wrench.
3. Remove and replace complete valve assembly.
4. Remove the pump head.
5. Remove the diaphragm bolt, support washer and diaphragm. Turn the pump shaft to up stroke to replace diaphragm.
6. Install new diaphragm, then replace washer and bolt.
7. Turn pump to downstroke to seat new diaphragm into the sleeve groove.
8. Replace pump head and manifold(s).
9. Refill crankcase with SAE30 non detergent oil (PumpRight Oil or hydraulic jack oil).

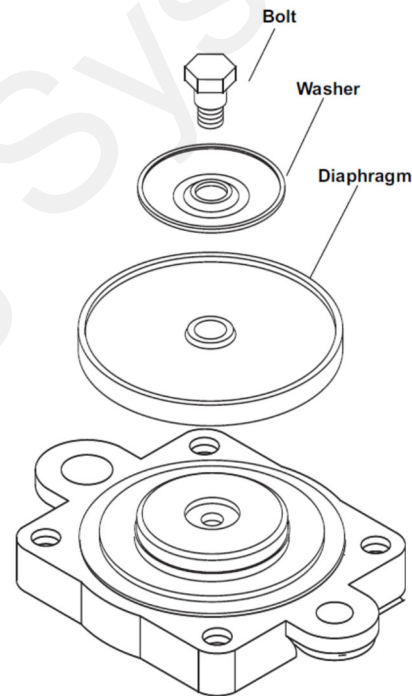

D70 - D115 Valves are on same side of head. Valves should pop out with slight screw-driver pressure.

D160 - D250 Valves (not shown) are arranged on opposite sides of head.

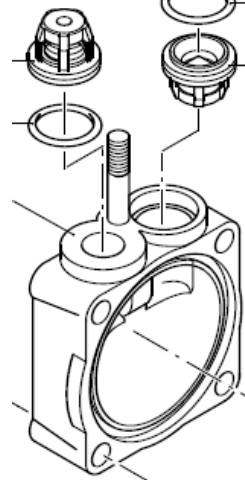

Other Service Parts D70, D115, D160, D250

Part Number (all begin 291-02-9910-xxxxxx)	Description
550080	Diaphragm (Buna, Optional)
550190	Accumulator Diaphragm



D70 Diaphragm Pump Parts

H

Maintenance
& Parts

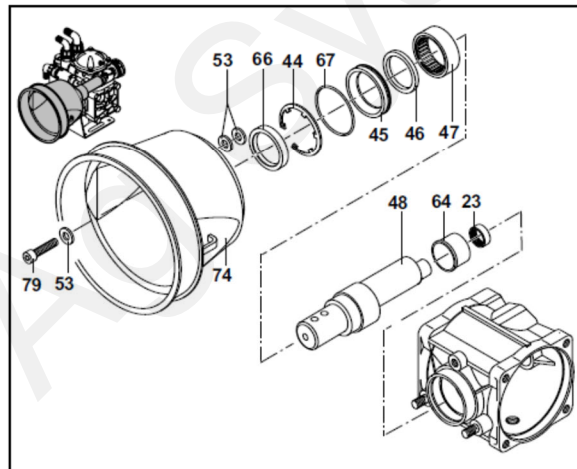
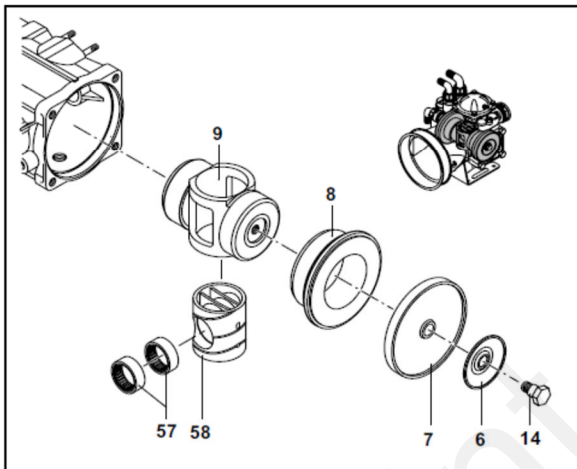
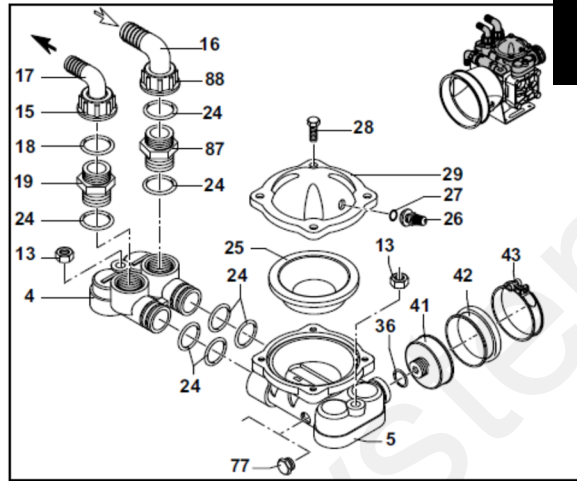
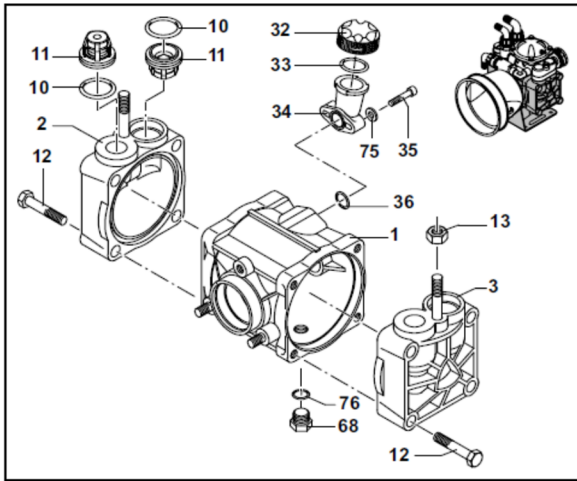

REF. NO.	PART NUMBER	DESCRIPTION	QTY. REQ'D
1	9910-550011	Pump Body with bolts	1
2	9910-550101	Right head DX	1
3	9910-550102	Left head SX	1
4	9910-550150	Manifold	1
5	9910-559200	Accumulator manifold	1
6	9910-580370	Plate	2
7	9910-550080	Diaphragm (Buna) Optional	2
7a	9910-550085	Diaphragm (Desmopan) Standard	2
8	9910-550110	Sleeve	2
9	9910-550120	Piston	1
10	9910-320030	O-ring	4
11	9910-759051	Complete valve assembly	4
12	9910-551040	M10 x 55 Bolt	8
13	9910-180152	Nut	4
14	9910-580360	Diaphragm bolt	2
15	9910-550880	Ring nut	1
16	9910-580040	Elbow 1-1/4"	1
17	9910-550370	Elbow 1"	1
18	9910-550350	O-ring	1
19	9910-550340	Threaded adapter	1
23	9910-550310	Roller bearing	1
24	9910-390290	O-ring	7
25	9910-550190	Accumulator diaphragm	1
26	9910-550300	Air valve	1
27	9910-650542	O-ring	1
28	9910-550680	Bolt	4
29	9910-559204	Upper air chamber	1

REF. NO.	PART NUMBER	DESCRIPTION	QTY. REQ'D
32	9910-550057	Sight glass cap	1
33	9910-550040	O-ring	1
34	9910-550030	Oil sight glass	2
36	9910-180101	O-ring	2
41	9910-650660	Diaphragm holder	1
42	9910-650670	Diaphragm	1
43	9910-650690	Clamp	1
44	9910-200391	Retainer ring	1
45	9910-550470	Seal ring	1
46	9910-550070	Spacer ring	1
47	9910-550060	Roller bushing	1
48	9910-550170	Shaft	1
52	9910-200233	Washer	2
53	9910-320621	Washer	5
57	9910-550280	Bearing	2
58	9910-550140	Cylinder	1
64	9910-550160	Spacer	1
66	9910-550491	Seal ring	1
67	9910-650920	O-ring	1
68	2406-0023	Oil drain plug	1
74	9910-1500350	Shield	1
75	9910-550332	Washer	2
76	9910-740290	O-ring	1
77	9910-330173	Plug	1
79	9910-620472	M10 x 20 Bolt	1
87	9910-450120	Threaded adapter	1
88	9910-550870	Ring nut	1

D115 Diaphragm Pump Parts

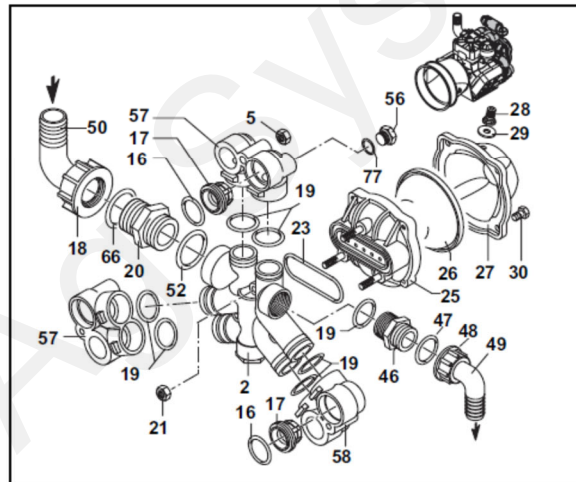
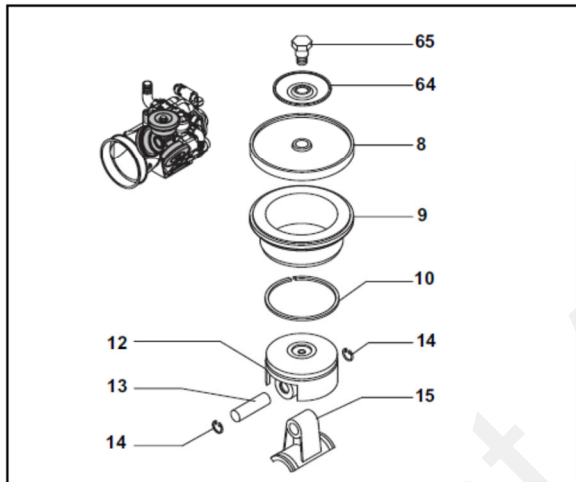
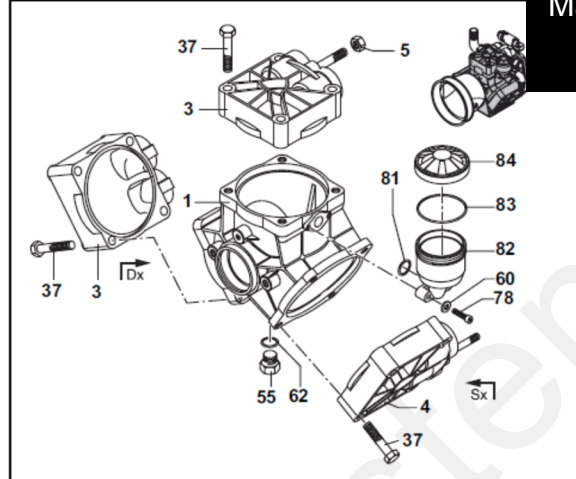
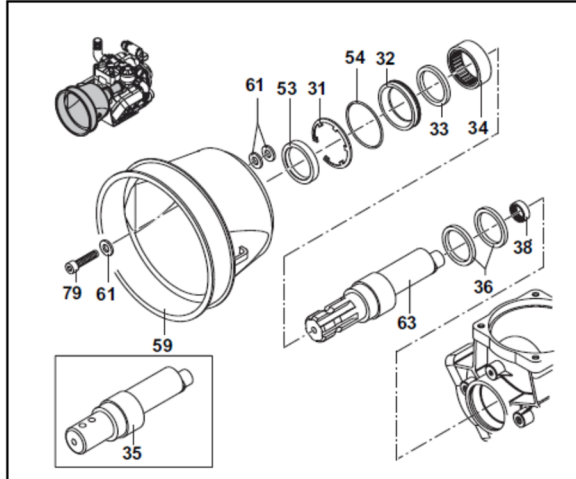

REF. NO.	PART NUMBER	DESCRIPTION	QTY. REQ'D
1	9910-580013	Pump body with bolts	1
2	9910-580150	Manifold	1
3	9910-550101	DX Right head	2
4	9910-550102	SX Left head	1
5	9910-180152	Nut	3
8	9910-550080	Diaphragm (Buna) Optional	3
9	9910-550085	Diaphragm (Desmopan) Standard	3
8	9910-580110	Sleeve (D115)	3
9	9910-580350	Sleeve (D135)	3
10	9910-500260	Piston ring	3
12	9910-580120	Piston	3
13	9910-380300	Pin	3
14	9910-380080	Pin ring	6
15	9910-580140	Connecting rod	3
16	9910-320030	O-ring	6
17	9910-759051	Complete valve	6
18	9910-540541	Ring nut	1
19	9910-390291	O-ring	7
20	9910-540530	Threaded adapter	1
21	9910-390271	Nut	3
23	9910-580050	Gasket	1
25	9910-580180	Accumulator manifold	1
26	9910-550190	Accumulator diaphragm	1
27	9910-559204	Accumulator head	1
28	9910-550300	Air valve	1
29	9910-650542	O-ring	1
30	9910-550680	M8 x 20 Bolt	4
31	9910-200391	Retainer ring	1
32	9910-550470	Gasket retainer	1
33	9910-550070	Spacer ring	1
34	9910-550060	Roller bearing	1
35	9910-550170	Shaft (D115)	1
36	9910-580470	Connecting rod ring	2

REF. NO.	PART NUMBER	DESCRIPTION	QTY. REQ'D
37	9910-551040	M10 x 55 Bolt	12
38	9910-550310	Roller bushing	1
46	9910-550340	Threaded adapter	1
47	9910-550350	O-ring	1
48	9910-550242	Ring nut	1
49	9910-550370	Elbow 1"	1
50	9910-540550	Elbow 1-1/2"	1
52	9910-250310	O-ring	1
53	9910-550491	Seal ring	1
54	9910-650920	O-ring	1
55	2406-0023	Oil drain plug	1
56	9910-330173	Plug	1
57	9910-589200	DX Right valve retainer w/plug/o-ring	2
58	9910-580072	SX Left valve retainer	1
59	9910-1500350	Shield	1
60	9910-550332	Washer	2
61	9910-320621	Washer	5
62	9910-740290	O-ring	1
63	9910-580330	Shaft (D135)	1
64	9910-580370	Plate	3
65	9910-580360	Diaphragm bolt	3
66	9910-250310	O-ring	1
69	9910-200233	Washer	2
77	9910-180101	O-ring	1
78	9910-850851	M6 x 30 Bolt	2
79	9910-620472	M10 x 20 Bolt	3
81	9910-390180	O-ring	1
82	9910-1040310	Oil sight glass	1
83	9910-650920	O-ring	1
84	9910-1040322	Black oil tank cap	1

D160 Diaphragm Pump Parts

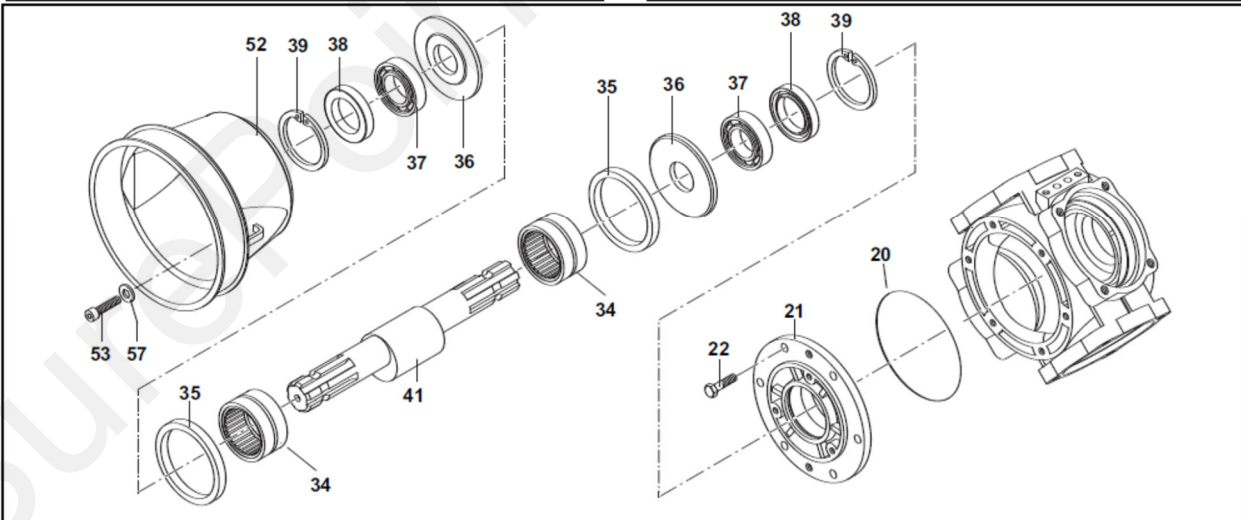
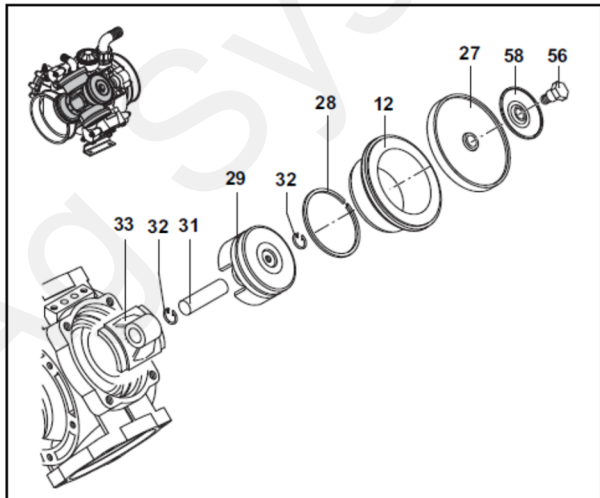
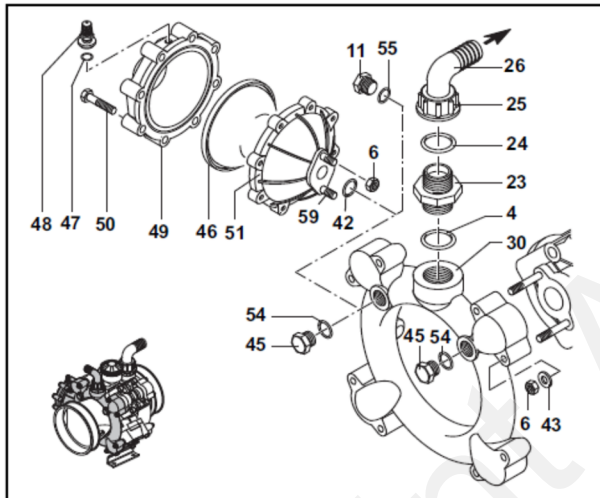
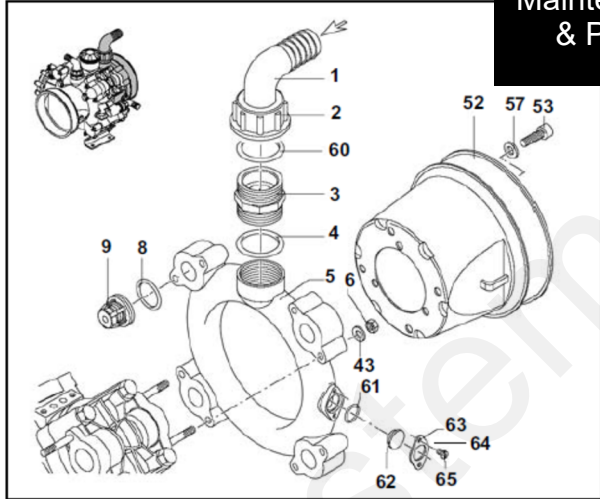
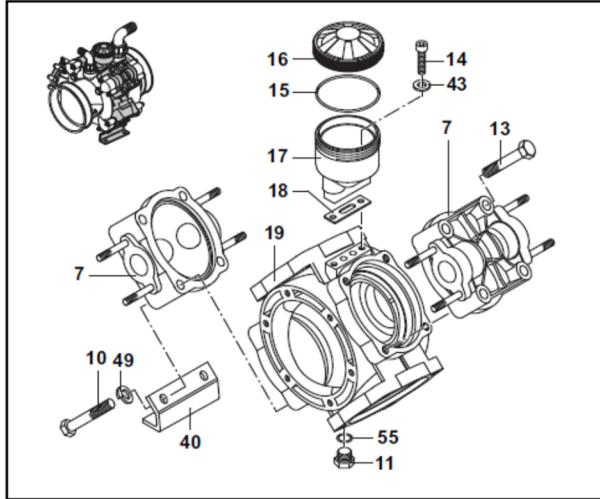

D160 Diaphragm Pump Parts

REF. NO.	PART NUMBER	DESCRIPTION	QTY. REQ'D
1	9910-760020	Elbow 2"	1
2	9910-760040	Ring nut	1
3	9910-760030	Threaded adapter	1
4	9910-250310	O-ring	1
5	9910-760220	Suction manifold	1
6	9910-380242	Nut	18
7	9910-750100	Head	4
8	9910-680070	O-ring	8
9	9910-759051	Complete valve	8
10	9910-750071	Bolt	4
11	2406-0023	Oil drain plug	2
12	9910-750110	Sleeve	4
13	9910-750061	M12 x 65 Bolt	12
14	9910-680350	M8 x 35 Bolt	2
15	9910-1040060	O-ring	1
16	9910-750057	Black oil tank cap	1
17	9910-750030	Oil sight glass	1
18	9910-750040	Gasket	1
19	9910-760010	Pump body	1
20	9910-851360	O-ring	1
21	9910-680020	Bearing support housing	1
22	9910-160672	M10 x 25Bolt	6
23	9910-540530	Threaded adapter	1
24	9910-250310	O-ring	1
25	9910-540540	Ring nut	1
26	9910-540550	Elbow 1-1/2"	1
27	9910-550085	Diaphragm (Desmopan) Standard	4
27a	9910-550080	Diaphragm (Buna) Optional	4
28	9910-500260	Piston ring	4
29	9910-750122	Piston	4
30	9910-760070	Manifold	1
31	9910-160700	Pin	4
32	9910-160691	Pin ring	8
33	9910-760140	Connecting rod	4
34	9910-750090	Roller bearing	2
35	9910-750130	Connecting rod ring	2
36	9910-540040	Spacer washer	2
37	9910-230350	Bearing	2
38	9910-160740	Seal ring	2
39	9910-200390	Retainer ring	2
40	9910-760201	Base	2
41	9910-750170	Crankshaft	1
42	9910-390290	O-ring	1
43	9910-380243	Washer	18
44	9910-250143	Washer	4
45	9910-330173	Plug	2
46	9910-550190	Accumulator diaphragm	1
47	9910-650542	O-ring	1
48	9910-180020	Air valve	1
49	9910-620232	Accumulator head	1
50	9910-621781	M8 x 40 Bolt	8
51	9910-680180	Accumulatorbody	1
52	9910-1500350	Shield	2
53	9910-850251	M8 x 12 Bolt	6
54	9910-180101	O-ring	2
55	9910-740290	O-ring	2
56	9910-580360	Diaphragm bolt	4
57	9910-390314	Washer	6
58	9910-580370	Retaining washer	4
59	9910-390670	Accumulator stud	1

REF. NO.	PART NUMBER	DESCRIPTION	QTY. REQ'D
60	9910-620210	Oring	1
61	9910-480440	Oring	1
62	9910-2420120	Flange Plug	1
63	9910-2420110	Flange	1
64	9910-2420290	Washer	2
65	9910-2420280	Bolt	2

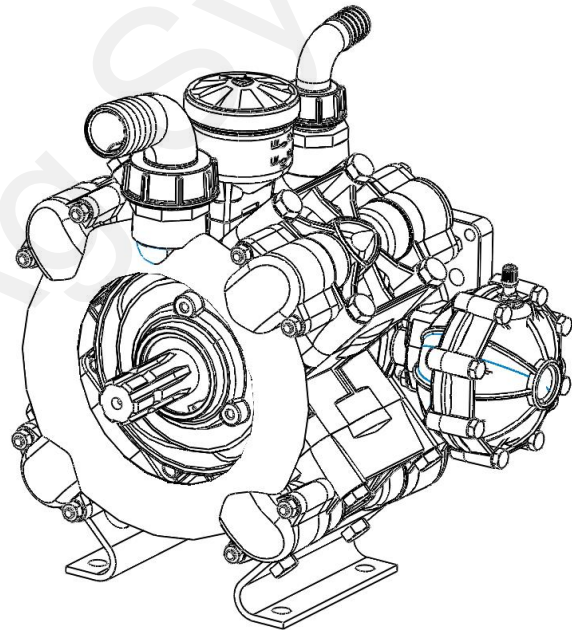

D250 Diaphragm Pump Parts

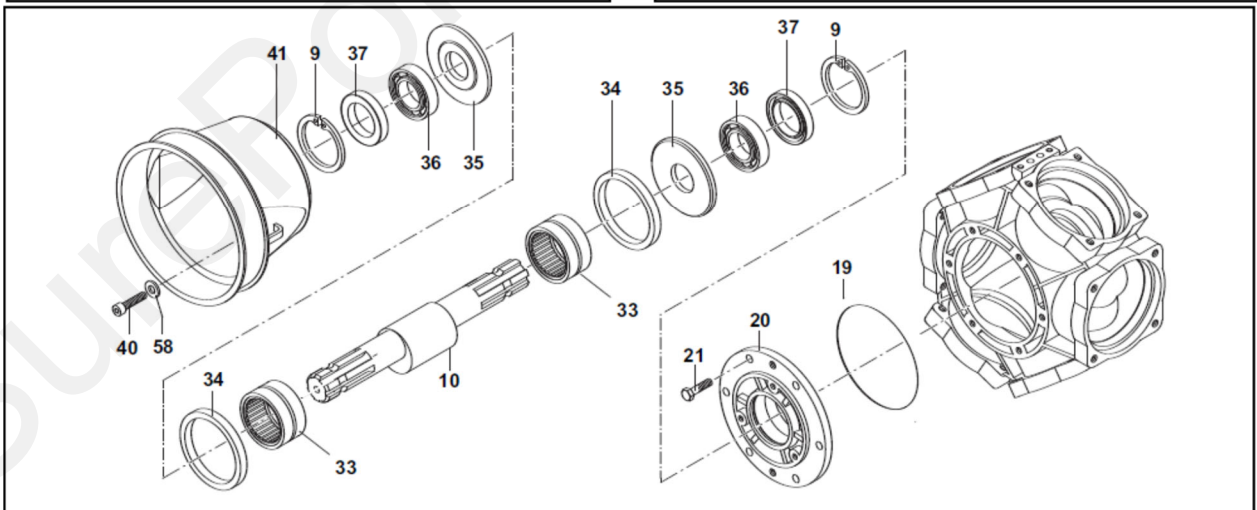
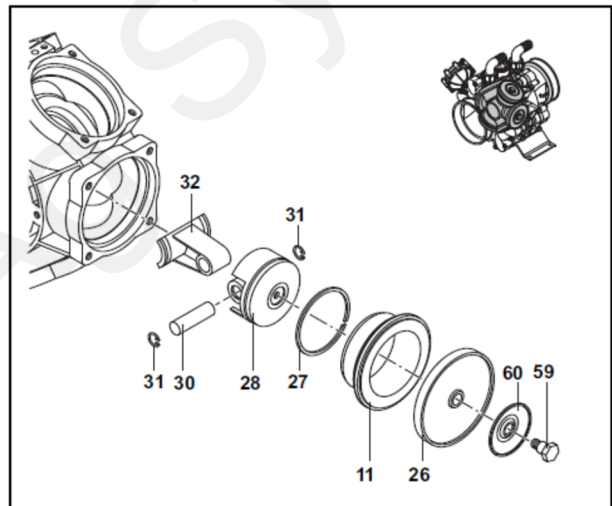
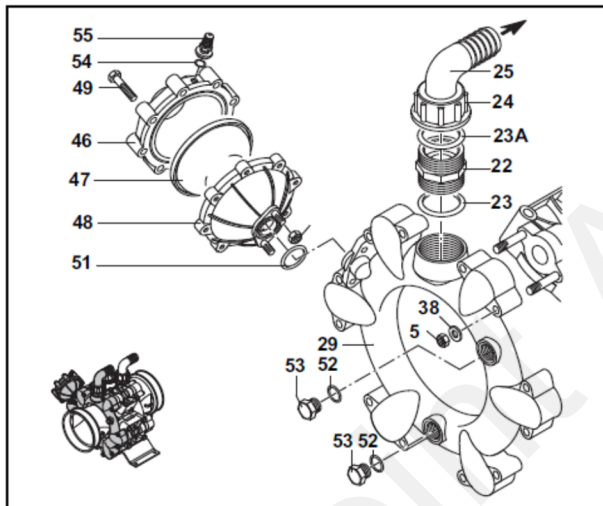
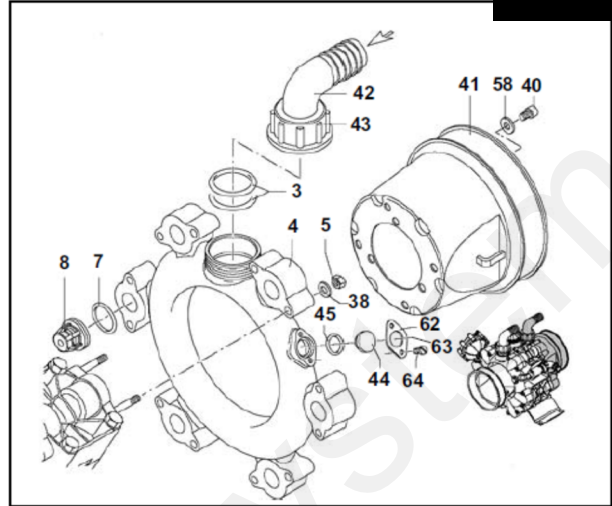
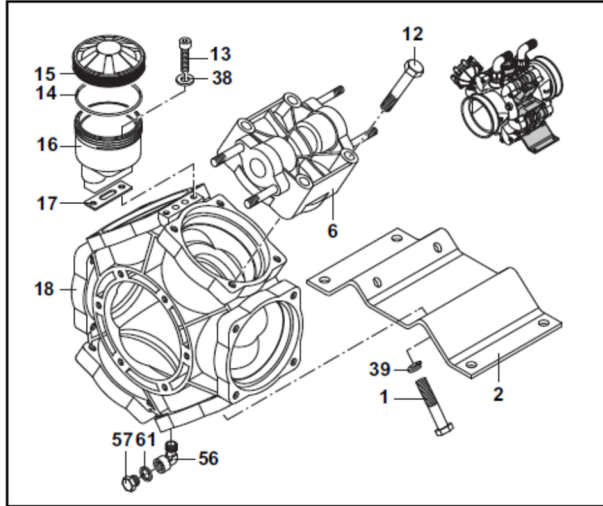

D250 Diaphragm Pump Parts

REF. NO.	PART NUMBER	DESCRIPTION	QTY. REQ'D
1	9910-750071	Bolt	4
2	9910-750200	Base	1
3	9910-750740	O-ring	2
4	9910-KIT2486	Suction Manifold Kit (Includes Ref. 3, 42, 43, 44, 45 and 62)	1
5	9910-380242	Nut	26
6	9910-750100	Head	6
7	9910-680070	O-ring	12
8	9910-759051	Complete valve	12
9	9910-200390	Retainer ring	2
10	9910-750170	Crankshaft	1
11	9910-750110	Sleeve	6
12	9910-750061	M12 x 65 Bolt	20
13	9910-680350	M8 x 35 Bolt	2
14	9910-1040060	O-ring	1
15	9910-750057	Black oil tank cap	1
16	9910-750030	Oil sight glass	1
17	9910-750040	Gasket	1
18	9910-750010	Pump body	1
19	9910-851360	O-ring	1
20	9910-680020	Shaft support	1
21	9910-160672	M10 x 25 Bolt	6
22	9910-751130	Threaded adapter	1
23	9910-751140	O-ring	1
23A	9910-390290	O-ring	1
24	9910-750670	Ring nut	1
25	FNE-112112	Elbow 1-1/2"	1
26	9910-550085	Diaphragm (Desmopan) Standard	6
26A	9910-550080	Diaphragm (Buna) Optional	6
27	9910-500260	Piston ring	6
28	9910-750122	Piston	6
29	9910-751080	Manifold	1
30	9910-160700	Pin	6
31	9910-160691	Pin ring	2
32	9910-750140	Connecting rod	6
33	9910-750090	Roller bearing	2
34	9910-750130	Connecting rod ring	2
35	9910-540040	Spacer washer	2
36	9910-230350	Bearing	2
37	9910-160740	Seal ring	2
38	9910-380243	Washer	26
39	9910-250143	Washer	4
40	9910-850251	M8 x 12 Bolt	6
41	9910-1500350	Shield	2
42	9910-750850	Elbow 2"	1
43	9910-750710	Ring nut	1
44	9910-2420120	Plug	1
45	9910-480440	O-ring	1
46	9910-620232	Accumulator head	1
47	9910-550190	Accumulator diaphragm	1
48	9910-680180	Accumulator body	1
49	9910-621781	M8 x 40 Bolt	8
51	9910-390290	O-ring	1
52	9910-180101	O-ring	2
53	9910-330173	Plug	2
54	9910-650542	Gasket	1
55	9910-180020	Air valve	1
56	9910-750370	Elbow	1
57	9910-880581	Oil drain plug	1
58	9910-390314	Washer	6
59	9910-580360	Diaphragm bolt	6

REF. NO.	PART NUMBER	DESCRIPTION	QTY. REQ'D
60	9910-580370	Retainer washer	6
61	9910-880820	Washer	1
62	9910-2420110	Flange	1
63	9910-2420290	Washer	2
64	9910-2420280	Bolt	2

